

AXOR[®]

AXOR

KOMFORT LINE K-3

Smart&Quick

Window hardware for PVC profiles





Content

	General product information
1	Hinges
2	Gears
3	Corner transmissions / Middle locks
4	Stay arm
5	Additional elements
6	Hardware set combinations
7	Installation tools
8	Profile-dependent elements

System KOMFORT LINE K-3 SMART&QUICK

General product information

System KOMFORT LINE K-3 SMART&QUICK

SMART&QUICK is an updated KOMFORT LINE K-3 window hardware system of AXOR INDUSTRY company.

AXOR design engineers set themselves the goal of improving this line of hardware and making it even more versatile and convenient to use. As a result, we got the updated Komfort Line K-3, which provides even higher assembly speed, but completely preserves its basic characteristics: comfortable operation, high quality and safety for end users.

The main advantages of updated **K-3 SMART&QUICK**:

- The changed face plate provides a higher rigidity of the profile section, which increased its bending resistance, and the flawless appearance will satisfy even the most demanding consumers;
- The increased linear dimensions of gears and stay arm allow PVC window producers use cutting tools (punching machines) for both straight and eccentric cuts when installing hardware;
- Better connection of gears and stay arm with corner transmission due to location of the driving rod 0.25 mm lower;
- Locking pins are located 0.25 mm lower, which will improve the operation of hardware set with micro ventilation and safety locking plates;
- The presence of corner transmissions for eccentric cut will significantly facilitate the work of PVC window producers.

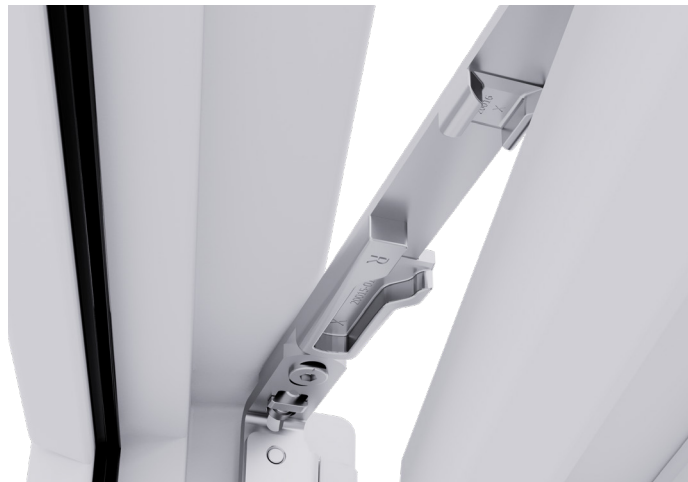

SMART&QUICK is the constant quality of AXOR Industry products, speed of assembly and versatility in using.

Application range

All window furniture in our catalogue is intended exclusively for the internal opening of windows and balcony doors.

The system K3 has been provided in such assemblies as, tilt and turn opening, single turn opening, single tilt opening and double sash opening as well.

Hardware elements

All sets of hardware, which were indicated in this catalogue, must consist only from original elements of AXOR INDUSTRY. Otherwise the producer won't be able to guarantee the work of hardware properly.

So, for each type of a sash, it is possible to set optional elements for additional functionality of one. These elements were marked with following colors:

Red – base safety;

Grey – possible equipment.

Quality

All products of AXOR INDUSTRY corresponds according to technical norms of DSTU Б B.2.6-39:2008, EN 13126-8 which regulate the main requirements of tilt and turn hardware.

Assembly

So, for accurate an assembly and for further correct work of hardware it is necessary to follow instructions of this catalogue.

Fixing of details:

The handle with screws M5 x 40mm.

The elements of a sash and the locking plates: self-tapping window chromated screws 4,0 x 25 mm or 3,9 x 26 mm.

The elements of hinges group: galvanized or alternatively chromated screws with flat head and cross-shaped slot, DIN 7982 3,9 x 32 mm or 3,9 x 38 mm.

Preliminary drilling is necessarily for these screws. Perforation instead of drilling is forbidden. Drill diameter for PVC profiles is 0,7, and for steel profiles is 0,8 diameter of a screw.

Settings of electric- or pneumatic screwdriver: maximum torque is 2.5 Nm, rotation speed: max 600 - 1000 rpm.

In case of non-compliance of these catalogue's recommendations for assembly and exploitation, the producer AXOR INDUSTRY cannot guarantee properly work of separate elements, as well as, the work of hardware system in whole.

The AXOR INDUSTRY Company reserves the right, in a process of further an improvement and development, to make technical changes of product KOMFORT LINE K-3, and also to change packaging norms.

Locking pins

General product information

Locking pins

The system of window hardware KOMFORT LINE K-3 SMART&QUICK was equipped with cylindrical pins of sliding.

Thus, as additional option it is possible to complement elements of a sash with a mushroom pin, to conform the base safety level according to AHS Standard. Or the FLAX anti-burglary pin, which adapts to the telescopic plate thanks to the possibility of linear displacement and rotation around its own axis.

In order to ensure air and water permeability of window and balcony door units in accordance with the DSTU Б B.2.6-39:2008 standards, the construction of turn, tilt and tilt&turn devices shall ensure that the contact between the sash (leaf) and the frame remains tight and even for the entire duration of service life, based on recommendations from the profile system manufacturers, the use of a certain type of gasket and observance of the required size of gap under the gasket, which means that when assembling a tilt-and-turn (turn) window, the manufacturer must receive recommendations regarding the number of and the distance between the locking points directly from the profile manufacturer, in writing and with the explanation of these requirements.

The adjustment range of locking pins is ± 1 mm. The diameter of pins is 11 mm.

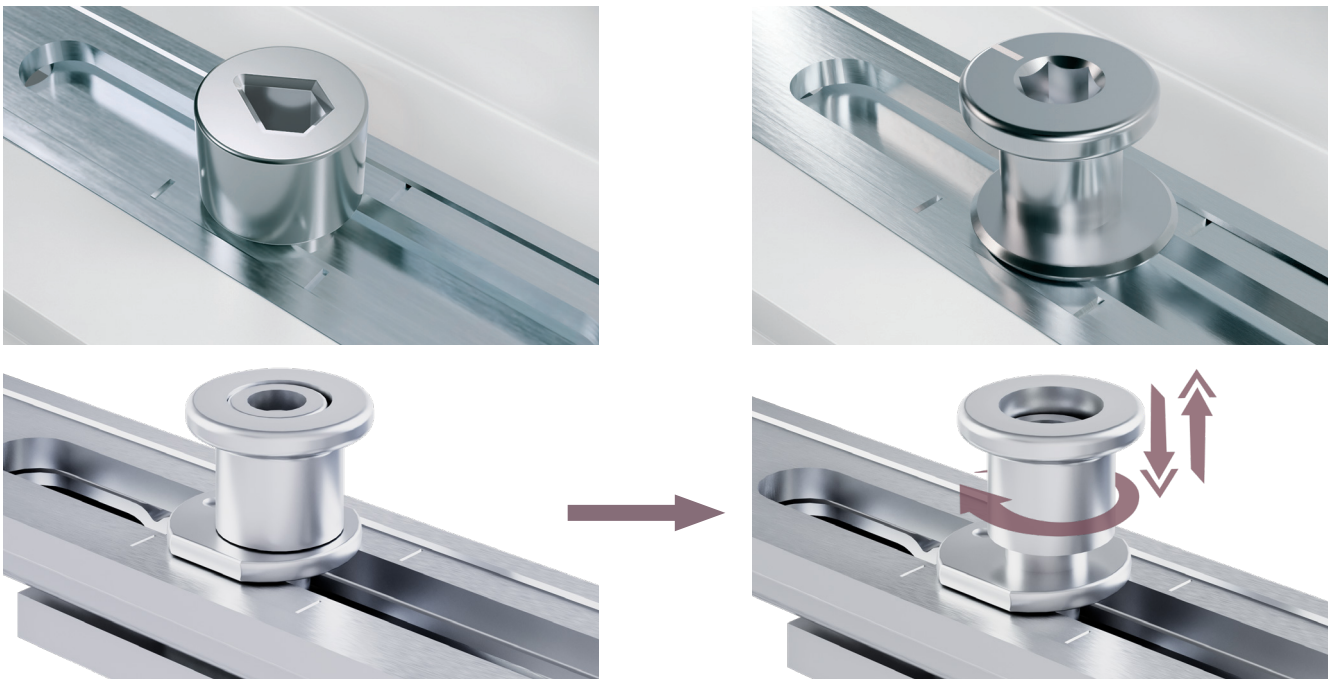

Technical features

There is an opportunity to fix the finger of the corner bearing at the extreme bottom position under angle 180° in order to make an assembly more comfortable by a screw gun, so the finger is not falling down and hindering to screw the screws.

3) The holes of the corner bearing and stay arm bearing were designed thus all screws to pass through reinforcement profile inside of a frame.

4) The drill-in corner hinge has two pins following sizes: length 5 mm and diameter 3 mm to fix reliably this one before the moment of screwing by screws.

5) There is a plastic bush, of high-strength polymer, inside of the drill-in corner hinge, which prevents unscrewing of an adjustable screw during the turning of a sash. Thus there is not any creak during of the turning of a sash. The adjustable screw of the drill-in corner hinge was fixed primordially in the central position to exclude unscrewing during transportation and exploitation of end product.

6) The finger of the stay arm bearing gets the hard and reliable fixation thanks to a special bush of high-strength polymer, excluding the disconnection by itself.

7) The antitheft locking plates with mushroom pins of the corner transmission and middle lock together allow equipping a window

according to requirements of the base safety according to AHS Standard.

8) The wrong operation safety device with sash lifter is universal for left and right opening. There is a fixation of the central position before a moment of assembly. It can work even the gap between the frame rebate and sash rebate is from 10,5 till 14 mm. Thus, if it is necessary there is an opportunity to adjust a lifting plate at ± 1 mm by height. So, the setting of the lifting plate with a special telescopic jig provides the correct work this wrong operation safety device whole.

9) The bottom extension has "a ski-lift" which was integrated to this one, thus it excludes the sagging down of a sash when it is closed.

10) The junction of the middle lock to the stay arm is quite reliably thanks to a screw, which joins these ones.

11) The adjustment range of the stay arm by a gasket pressing is ± 1 mm.

12) There are five types of middle locks thus, it is quite useful for an optimization of a warehouse and for logistics too.



The protective plating of KOMFORT LINE K-3 SMART & QUICK

The quality of the plating of all hardware's elements affects at the work of accessories, durability and surface appearance very much.

Thus, the special technology of galvanizing allows getting the high-quality plating, which provides all elements of KOMFORT LINE K-3 required level of protect against corrosion.

Nevertheless, a silver color of the hardware's surface appearance fulfills a decorative function to allow it to combine successfully with the others elements of a window.



The causes to appear the corrosion at hardware's surface.

- 1) The prolonged exposure of high wetness (more than 70%).
- 2) The polluted air with gas, comprising a connection of various acids, and an exposure of salt-mist.
- 3) The mechanical damages of surface during an assembly or maintenance, which disrupt wholeness of the plating.
- 4) Some cleaning agents include alkali, acid and so on.
- 5) Under the influence of different temperature there can appear the formation of condensate at the surface of hardware.
- 6) The pollution with some building materials, in particular by cement or gypsum plaster.

Some instructions to keep the quality of surface plating

- 1) Avoid hits of building materials at the hardware surface, for example plaster, cement, different building solutes and building dust.
- 2) Avoid any exposure of aggressive acidic steam and salt-mists at the hardware surface.
- 3) Do not use any rubber gasket, which is able to soaks up and to hold some moisture.
- 4) The cleaning should be made with pH-neutral solute, before diluted.
- 5) Do not permit any mechanical damages of the hardware's surface by building, assembly and detergent instruments.

Storage conditions

This applies to storage and transport, as well as for unloading and loading procedures. Where appropriate, plastic protective sheets or similar are to be used during outdoor transport when raining (i.e. on-site transport). Storage may only be carried out in suitable, closed rooms and not outdoors. Condensation is to be absolutely avoided during the entire transport and storage duration.

- 1) Always keep the hardware boxes closed, and always cover up hardware boxes which were opened and do not put boxes directly on the floor.
- 2) Transport the hardware always with suitable devices (if possible on pallets with stretch film).
- 3) The components may not get wet. The packaging must remain dry (it is recommended: Warehouse temperature – 15-25°C; Relative humidity – less then 50%).
- 4) If box becomes wet please immediately unpack the components from the wet bundles, dry the components and check for signs of corrosion. In any case repack the usable components when dry with new packing material.

Basic notations and representation of the information

General product information

Basic notations

	Maximum sash weight, kg		Cylindrical locking pin (ML)
	Screws (quantity/size)		Mushroom locking pin (MR)
	Packaging quantity (pcs)		FLAX locking pin (FX)
	Drill-bit (diameter)		Locking plate for double-sash window



Tilt and turn sash

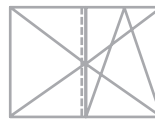

Tilt and turn double sash



Turn-only sash



Tilt-only sash



Arched tilt and turn sash



Tilt and turn sash for oblique windows



Sliding sash

Representation of the information

All article numbers in this catalogue were afforded an alphanumeric form. The decipher of all article numbers you can find at the pages 8-9.

Thus, all sizes which were shown in that catalogue are nominal and contain general tolerances.

All sizes were conferred in mm.

The information about restriction of sashes' sizes should be taken from diagrams of this catalogue or a user's guide.



The single sash constructions

Sash rebate gap (A):	min. 12 mm
Sash overlap (C):	18 – 22 mm
Sash groove position (B):	9 mm

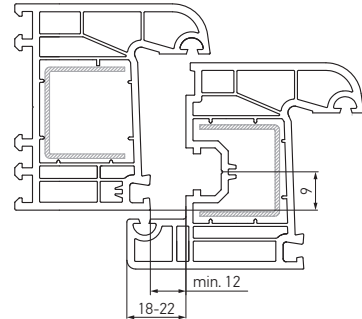

Sash rebate gap (A):	min. 12 mm
Sash overlap (C):	18 – 22 mm
Sash groove position (B):	13 mm

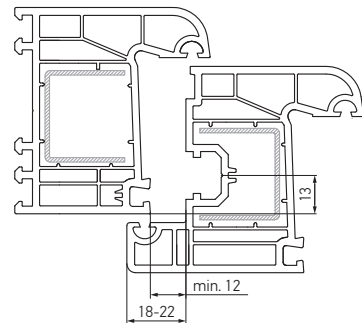

The double sash constructions with opposite hardware groove

Sash rebate gap (A):	min. 12 mm
Sash overlap (C):	18 – 22 mm
Sash groove position (B):	9 mm

The handling of a passive sash with double sash's gears K1002-XX-N03

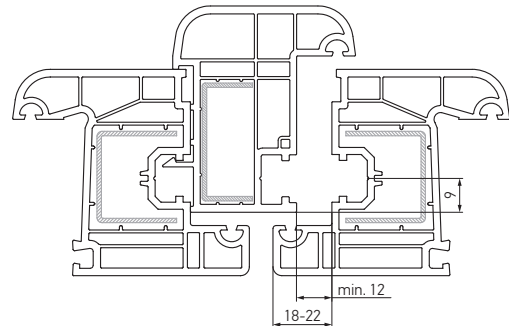

Sash rebate gap (A):	min. 12 mm
Sash overlap (C):	18 – 22 mm
Sash groove position (B):	13 mm

The handling of a passive sash with double sash's gears K1002-XX-N03

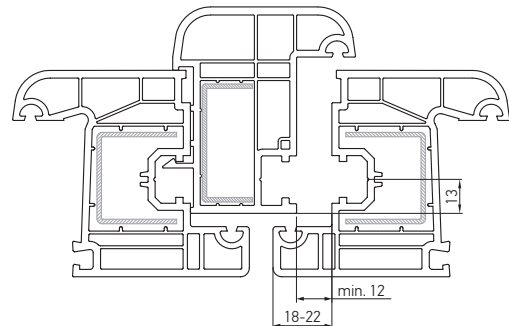

The information about profile-dependent elements you find at the profile list

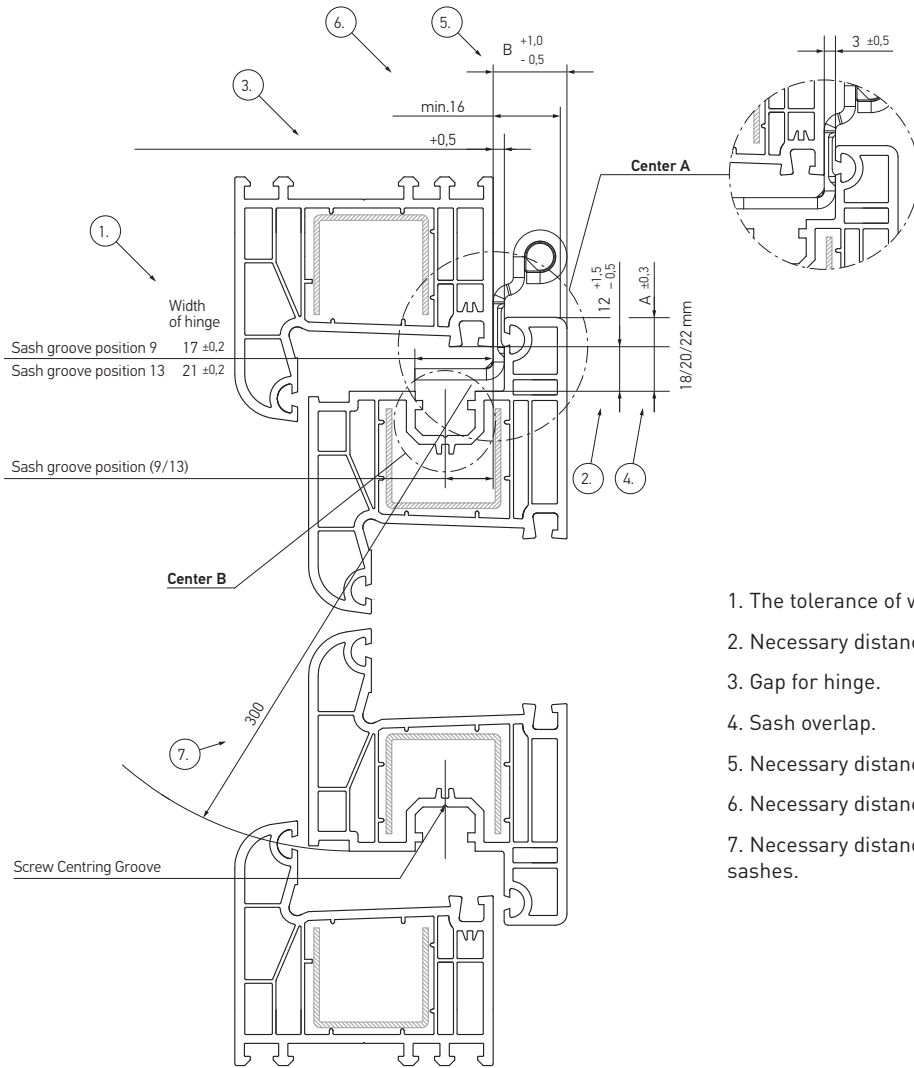
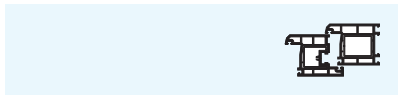

1. The tolerance of width for top sash's hinge.
2. Necessary distance for moving the hardware.
3. Gap for hinge.
4. Sash overlap.
5. Necessary distance for the clamping of gasket adjustment.
6. Necessary distance for inserting a hinge into sash overlap.
7. Necessary distance for operation of small turn and tilt-turn sashes.

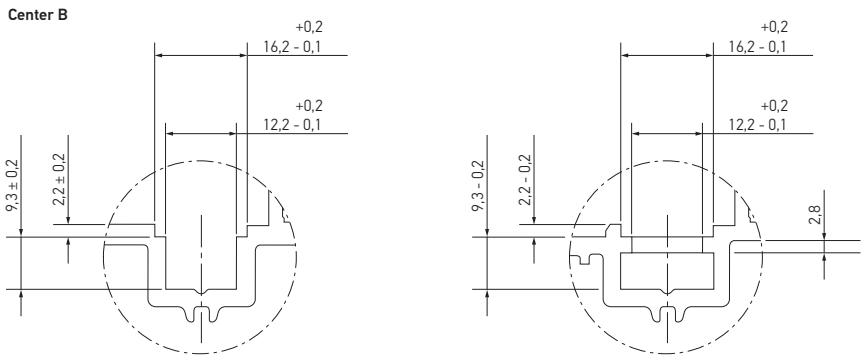

Dimensions for plastic profile according RAL as of February 1998.

Gütegemeinschaft Schlösser und Beschläge e.V.,
Offerstr. 12, 42551 Velbert



Article structure

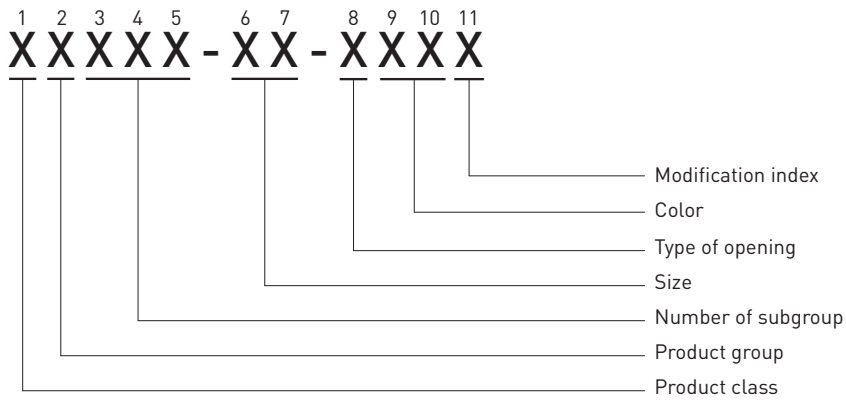

1. Product class
(1st sign)

XXXXX-XX-XXXX

"S" – smart line

"K" – komfort line

"A" – element refers to both classes

2. Product group
(2nd sign)

X**X**XXX-XX-XXXX

"0" – alternative value

"1" – gear variable

"2" – corner transmissions

"3" – stay arm

"4" – extensions

"5" – hinges

"6" – standart locking plates,
tilt locking plates

"7" – locking plates and the other
accessories

"8" – alternative value

"9" – alternative value

3-5. Subgroup number
(3rd, 4th, 5th sign)

Xx**XXX**-XX-XXXX

Additional information about product's subgroup.

Example: group "gears", subgroup "double sash lever espagnolette variable".

6-7. Size
(6th, 7th sign)

XXXXX-**XX**-XXXX

Important dimensions of the product such as the length of the axis, etc.



**8. Type of opening
(8th sign)**

XXXXX-XX-**X**XXX

“N” – universal

“R” – right

“L” – left

**9, 10. Color and plating
(9th and 10th sign)**

XXXXX-XX-X**XX**X

The ninth symbol indicates the color hue:

0 – basic color. For example, RAL9016 is the basic for white color, it is indicated by the code **01**; RAL8022 is the basic for brown color – **02**, etc.

1 – additional color. For example, RAL8019 for brown color – **12**.

2...9 – following additional colors.

The tenth character indicates the color:

0 – plating	4 – champagne	8 – steel surface
1 – white	5 – gold	9 – special colors
2 – brown	6 – bronze	
3 – silver	7 – black	

By default, all surfaces are glossy and this is not indicated separately in the article. Matte surfaces are marked with the letter **M** after the 10th symbol.

**11. Modification index (A, B, C)
(11th sign)**



Application range diagrams

General product information

Tilt and turn

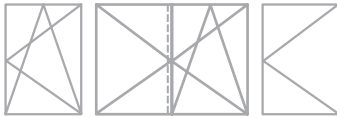

Valid sash's size

Permissible sash's weight for this range is 100 kg max.
 Profile weight: max. 3.05 kg/m.
 Aspect ratio (W:H): 2:1.

Valid sash's size

Permissible sash's weight for this range is 130 kg max.
 Profile weight: max. 3.05 kg/m.
 Aspect ratio (W:H): 2:1.

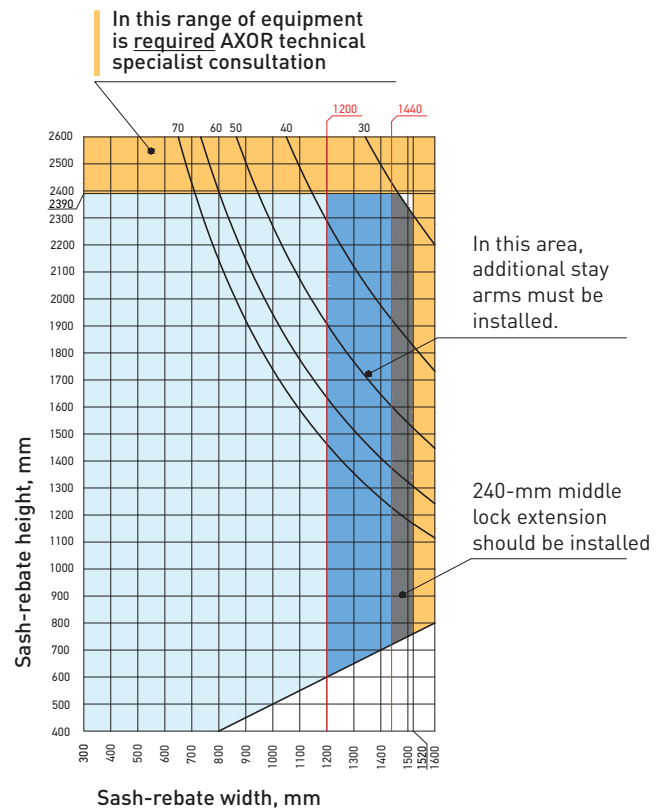
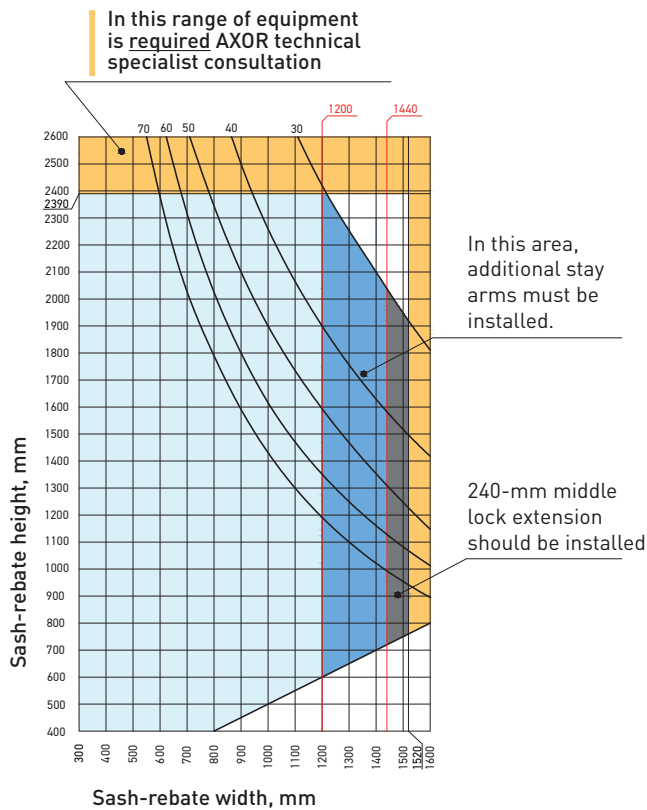

Tilt sash



Sash dimensions limits
 Maximum sash weight is 50 kg

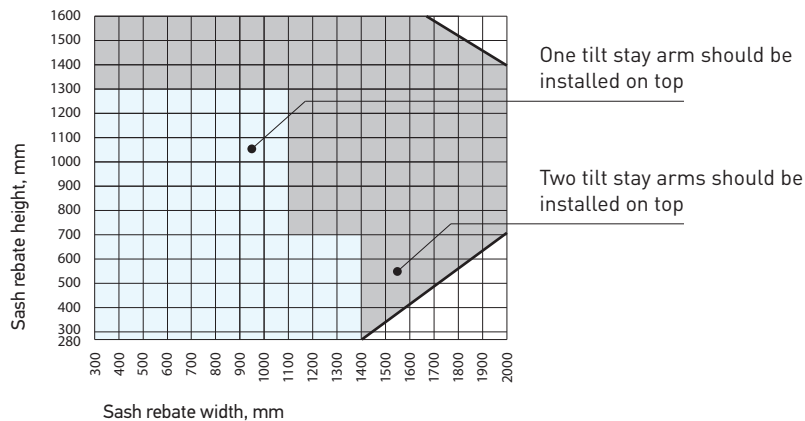

Safety conventional symbols

Conventional symbol	Meaning
	<p>Danger of injury through trapping of body parts</p> <ul style="list-style-type: none"> • Never reach into the opening between the sash and the outer frame when closing windows/doors.
	<p>Risk of injury from falling through open windows</p> <ul style="list-style-type: none"> • Always use stable step ladders. • Protect yourself against falling out of windows. • Do not steady yourself or hold on to the opened sash.
	<p>Risk of injury or damage from pressing the sash against the reveal</p> <ul style="list-style-type: none"> • Do not press the sash against the window reveal.
	<p>Risk of injury from trapping parts of the body between the sash and the frame</p> <ul style="list-style-type: none"> • Do not insert obstructions into the opening between sash and frame.
	<p>Risk of injury and material damage from overloading the sash</p> <ul style="list-style-type: none"> • Do not overload the sash.
	<p>Risk of injury from the effect of wind</p> <ul style="list-style-type: none"> • Prevent wind from acting on the open sash. • During wind/drafts, close and lock windows.

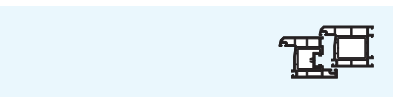

Certificate ISO 9001:2015



CERTIFICATE

No. 3800266

This is to certify that the Quality Management System of the company



Limited Liability Company "AXOR INDUSTRY"
 Pavašev. 32
 49041 Dnipro
 Ukraine

has been assessed and found to be in compliance with the Standard

ISO 9001:2015

applicable to

Manufacture and selling of turn, tilt and tilt & turn hardware for windows and balcony doors.

The certificate has been issued under No. 3800266 for the registration period from 22 April 2024 to 21 April 2027.
 The first certificate date of issue is 22 April 2024.

 Approved by

 Printed by





Validity code: 390899E3-ATC
 Check the validity of this certificate using this code at www.ll-c.info

LL-C (Certification) Czech Republic a.s. | Pohořínská 620/3, 186 00 Praha 8

Certificate QM 328:2018-01

Zertifikat / Certificate

Zertifikatsnr. / Certificate No.: 228-9003481-1-10

Dreh- und Drehkippschlässe für Fenster und Fenstertüren
Turn and tilt-turn hardware for windows and casement doors

Produkt max. Flügelgewicht max. Casement weight	Komfort Line K-3 Smart&Quick, AXOR Elite Plus, Axor Elite 130 kg
Einsatzbereich field of application	Systeme mit entsprechender Beschlagenaufnahme Systems with suitable hardware groove
Hersteller manufacturer	AXOR Industry Virskoho Pavašev. street 1, UA 49083 Dnipro
Produktionsstandort production site	AXOR INDUSTRY LLC Trade av. 32, UA 49041 Dnipro

Mit diesem Zertifikat wird bestätigt, dass das benannte Bauprodukt den Anforderungen des zugrundeliegenden R-Zertifizierungsprogramms in der aktuellen Fassung entspricht.

II Erstellung von Produktfamilien, die aufeinander abgestimmte und Typisierung durch eine selektierte Einweisung nach EN 12538-2:2017 unter Berücksichtigung der Abmessungsgruppen.

II Einführung und Aufrechterhaltung einer wirksamen Produktionskontrolle durch den Hersteller.

II Einhaltung des Werkes und der weitestgehenden Produktionskontrolle durch R-Cert.

II kontinuierliche Fernüberwachung des Werkes und der weitestgehenden Produktionskontrolle durch R-Cert.

Dieses Zertifikat wurde erstmals am 21.05.2014 ausgestellt. Die aktuelle Version gilt bis zum 20.05.2025, wenn sich zeitweilig die Festlegungen in der oben angeführten Normen- und Spezifikation oder der Beschlagenaufnahme in Werk oder in der weitestgehenden Produktionskontrolle nicht wesentlich verändert haben.

Dieses Zertifikat darf nur unter der Voraussetzung werden, dass Änderungen der Voraussetzungen für die Zertifizierung nach R-Cert mit den erforderlichen Nachweisen unverzüglich schriftlich anzuzeigen.

Dieses Unternehmen ist berechtigt, das benannte Bauprodukt gemäß der R-Zertifizierung mit dem R-Zertifikat-Zeichen zu kennzeichnen.

Dieses Zertifikat enthält 2 Anlagen.

This certificate attests that the building product mentioned fulfills the requirements of the underlying R-certification scheme in its current version.

II completion of product families of the building product listed and specifying by an accredited testing body as per EN 12538-2:2017 based on the application figures.

II implementation and maintenance of a factory production control by the manufacturer.

II initial inspection of the production site and the factory production control by R-Cert.

II continuous third-party control of the production site and the factory production control by R-Cert.

This certificate was first issued on 21.05.2014. The current version is valid until 20.05.2025, as long as neither the conditions laid down in the technical specification listed above nor the manufacturing conditions in the production site nor the factory production control meet the modified conformity.

The reproduction of the certificate without any change from the original is permitted. Any changes to the preconditions applicable to certification shall be immediately communicated in writing to R-Cert accompanied by the necessary evidence.

The company is authorized to affix the R-certification mark to the building product mentioned according to the R-rules on the use of the R-certification mark.

This certificate contains 2 annexes.

ift
ROSENHEIM

Zertifikatsnr. / Certificate No.: 228-9003481-1-10

Grundlagen / Basis:
R-Zertifizierungsprogramm für Beschläge
R-Zertifizierung QM328:2018-01

EN 1191
EN 12400
EN 12403
EN 12404
EN 12405
EN 12406
EN 12407
EN 12408
EN 12409
EN 12410
EN 12411
EN 12412
EN 12413
EN 12414
EN 12415
EN 12416
EN 12417
EN 12418
EN 12419
EN 12420
EN 12421
EN 12422
EN 12423
EN 12424
EN 12425
EN 12426
EN 12427
EN 12428
EN 12429
EN 12430
EN 12431
EN 12432
EN 12433
EN 12434
EN 12435
EN 12436
EN 12437
EN 12438
EN 12439
EN 12440
EN 12441
EN 12442
EN 12443
EN 12444
EN 12445
EN 12446
EN 12447
EN 12448
EN 12449
EN 12450
EN 12451
EN 12452
EN 12453
EN 12454
EN 12455
EN 12456
EN 12457
EN 12458
EN 12459
EN 12460
EN 12461
EN 12462
EN 12463
EN 12464
EN 12465
EN 12466
EN 12467
EN 12468
EN 12469
EN 12470
EN 12471
EN 12472
EN 12473
EN 12474
EN 12475
EN 12476
EN 12477
EN 12478
EN 12479
EN 12480
EN 12481
EN 12482
EN 12483
EN 12484
EN 12485
EN 12486
EN 12487
EN 12488
EN 12489
EN 12490
EN 12491
EN 12492
EN 12493
EN 12494
EN 12495
EN 12496
EN 12497
EN 12498
EN 12499
EN 12500
EN 12501
EN 12502
EN 12503
EN 12504
EN 12505
EN 12506
EN 12507
EN 12508
EN 12509
EN 12510
EN 12511
EN 12512
EN 12513
EN 12514
EN 12515
EN 12516
EN 12517
EN 12518
EN 12519
EN 12520
EN 12521
EN 12522
EN 12523
EN 12524
EN 12525
EN 12526
EN 12527
EN 12528
EN 12529
EN 12530
EN 12531
EN 12532
EN 12533
EN 12534
EN 12535
EN 12536
EN 12537
EN 12538
EN 12539
EN 12540
EN 12541
EN 12542
EN 12543
EN 12544
EN 12545
EN 12546
EN 12547
EN 12548
EN 12549
EN 12550
EN 12551
EN 12552
EN 12553
EN 12554
EN 12555
EN 12556
EN 12557
EN 12558
EN 12559
EN 12560
EN 12561
EN 12562
EN 12563
EN 12564
EN 12565
EN 12566
EN 12567
EN 12568
EN 12569
EN 12570
EN 12571
EN 12572
EN 12573
EN 12574
EN 12575
EN 12576
EN 12577
EN 12578
EN 12579
EN 12580
EN 12581
EN 12582
EN 12583
EN 12584
EN 12585
EN 12586
EN 12587
EN 12588
EN 12589
EN 12590
EN 12591
EN 12592
EN 12593
EN 12594
EN 12595
EN 12596
EN 12597
EN 12598
EN 12599
EN 12600
EN 12601
EN 12602
EN 12603
EN 12604
EN 12605
EN 12606
EN 12607
EN 12608
EN 12609
EN 12610
EN 12611
EN 12612
EN 12613
EN 12614
EN 12615
EN 12616
EN 12617
EN 12618
EN 12619
EN 12620
EN 12621
EN 12622
EN 12623
EN 12624
EN 12625
EN 12626
EN 12627
EN 12628
EN 12629
EN 12630
EN 12631
EN 12632
EN 12633
EN 12634
EN 12635
EN 12636
EN 12637
EN 12638
EN 12639
EN 12640
EN 12641
EN 12642
EN 12643
EN 12644
EN 12645
EN 12646
EN 12647
EN 12648
EN 12649
EN 12650
EN 12651
EN 12652
EN 12653
EN 12654
EN 12655
EN 12656
EN 12657
EN 12658
EN 12659
EN 12660
EN 12661
EN 12662
EN 12663
EN 12664
EN 12665
EN 12666
EN 12667
EN 12668
EN 12669
EN 12670
EN 12671
EN 12672
EN 12673
EN 12674
EN 12675
EN 12676
EN 12677
EN 12678
EN 12679
EN 12680
EN 12681
EN 12682
EN 12683
EN 12684
EN 12685
EN 12686
EN 12687
EN 12688
EN 12689
EN 12690
EN 12691
EN 12692
EN 12693
EN 12694
EN 12695
EN 12696
EN 12697
EN 12698
EN 12699
EN 12700
EN 12701
EN 12702
EN 12703
EN 12704
EN 12705
EN 12706
EN 12707
EN 12708
EN 12709
EN 12710
EN 12711
EN 12712
EN 12713
EN 12714
EN 12715
EN 12716
EN 12717
EN 12718
EN 12719
EN 12720
EN 12721
EN 12722
EN 12723
EN 12724
EN 12725
EN 12726
EN 12727
EN 12728
EN 12729
EN 12730
EN 12731
EN 12732
EN 12733
EN 12734
EN 12735
EN 12736
EN 12737
EN 12738
EN 12739
EN 12740
EN 12741
EN 12742
EN 12743
EN 12744
EN 12745
EN 12746
EN 12747
EN 12748
EN 12749
EN 12750
EN 12751
EN 12752
EN 12753
EN 12754
EN 12755
EN 12756
EN 12757
EN 12758
EN 12759
EN 12760
EN 12761
EN 12762
EN 12763
EN 12764
EN 12765
EN 12766
EN 12767
EN 12768
EN 12769
EN 12770
EN 12771
EN 12772
EN 12773
EN 12774
EN 12775
EN 12776
EN 12777
EN 12778
EN 12779
EN 12780
EN 12781
EN 12782
EN 12783
EN 12784
EN 12785
EN 12786
EN 12787
EN 12788
EN 12789
EN 12790
EN 12791
EN 12792
EN 12793
EN 12794
EN 12795
EN 12796
EN 12797
EN 12798
EN 12799
EN 12800
EN 12801
EN 12802
EN 12803
EN 12804
EN 12805
EN 12806
EN 12807
EN 12808
EN 12809
EN 12810
EN 12811
EN 12812
EN 12813
EN 12814
EN 12815
EN 12816
EN 12817
EN 12818
EN 12819
EN 12820
EN 12821
EN 12822
EN 12823
EN 12824
EN 12825
EN 12826
EN 12827
EN 12828
EN 12829
EN 12830
EN 12831
EN 12832
EN 12833
EN 12834
EN 12835
EN 12836
EN 12837
EN 12838
EN 12839
EN 12840
EN 12841
EN 12842
EN 12843
EN 12844
EN 12845
EN 12846
EN 12847
EN 12848
EN 12849
EN 12850
EN 12851
EN 12852
EN 12853
EN 12854
EN 12855
EN 12856
EN 12857
EN 12858
EN 12859
EN 12860
EN 12861
EN 12862
EN 12863
EN 12864
EN 12865
EN 12866
EN 12867
EN 12868
EN 12869
EN 12870
EN 12871
EN 12872
EN 12873
EN 12874
EN 12875
EN 12876
EN 12877
EN 12878
EN 12879
EN 12880
EN 12881
EN 12882
EN 12883
EN 12884
EN 12885
EN 12886
EN 12887
EN 12888
EN 12889
EN 12890
EN 12891
EN 12892
EN 12893
EN 12894
EN 12895
EN 12896
EN 12897
EN 12898
EN 12899
EN 12900
EN 12901
EN 12902
EN 12903
EN 12904
EN 12905
EN 12906
EN 12907
EN 12908
EN 12909
EN 12910
EN 12911
EN 12912
EN 12913
EN 12914
EN 12915
EN 12916
EN 12917
EN 12918
EN 12919
EN 12920
EN 12921
EN 12922
EN 12923
EN 12924
EN 12925
EN 12926
EN 12927
EN 12928
EN 12929
EN 12930
EN 12931
EN 12932
EN 12933
EN 12934
EN 12935
EN 12936
EN 12937
EN 12938
EN 12939
EN 12940
EN 12941
EN 12942
EN 12943
EN 12944
EN 12945
EN 12946
EN 12947
EN 12948
EN 12949
EN 12950
EN 12951
EN 12952
EN 12953
EN 12954
EN 12955
EN 12956
EN 12957
EN 12958
EN 12959
EN 12960
EN 12961
EN 12962
EN 12963
EN 12964
EN 12965
EN 12966
EN 12967
EN 12968
EN 12969
EN 12970
EN 12971
EN 12972
EN 12973
EN 12974
EN 12975
EN 12976
EN 12977
EN 12978
EN 12979
EN 12980
EN 12981
EN 12982
EN 12983
EN 12984
EN 12985
EN 12986
EN 12987
EN 12988
EN 12989
EN 12990
EN 12991
EN 12992
EN 12993
EN 12994
EN 12995
EN 12996
EN 12997
EN 12998
EN 12999
EN 13000
EN 13001
EN 13002
EN 13003
EN 13004
EN 13005
EN 13006
EN 13007
EN 13008
EN 13009
EN 13010
EN 13011
EN 13012
EN 13013
EN 13014
EN 13015
EN 13016
EN 13017
EN 13018
EN 13019
EN 13020
EN 13021
EN 13022
EN 13023
EN 13024
EN 13025
EN 13026
EN 13027
EN 13028
EN 13029
EN 13030
EN 13031
EN 13032
EN 13033
EN 13034
EN 13035
EN 13036
EN 13037
EN 13038
EN 13039
EN 13040
EN 13041
EN 13042
EN 13043
EN 13044
EN 13045
EN 13046
EN 13047
EN 13048
EN 13049
EN 13050
EN 13051
EN 13052
EN 13053
EN 13054
EN 13055
EN 13056
EN 13057
EN 13058
EN 13059
EN 13060
EN 13061
EN 13062
EN 13063
EN 13064
EN 13065
EN 13066
EN 13067
EN 13068
EN 13069
EN 13070
EN 13071
EN 13072
EN 13073
EN 13074
EN 13075
EN 13076
EN 13077
EN 13078
EN 13079
EN 13080
EN 13081
EN 13082
EN 13083
EN 13084
EN 13085
EN 13086
EN 13087
EN 13088
EN 13089
EN 13090
EN 13091
EN 13092
EN 13093
EN 13094
EN 13095
EN 13096
EN 13097
EN 13098
EN 13099
EN 13100
EN 13101
EN 13102
EN 13103
EN 13104
EN 13105
EN 13106
EN 13107
EN 13108
EN 13109
EN 13110
EN 13111
EN 13112
EN 13113
EN 13114
EN 13115
EN 13116
EN 13117
EN 13118
EN 13119
EN 13120
EN 13121
EN 13122
EN 13123
EN 13124
EN 13125
EN 13126
EN 13127
EN 13128
EN 13129
EN 13130
EN 13131
EN 13132
EN 13133
EN 13134
EN 13135
EN 13136
EN 13137
EN 13138
EN 13139
EN 13140
EN 13141
EN 13142
EN 13143
EN 13144
EN 13145
EN 13146
EN 13147
EN 13148
EN 13149
EN 13150
EN 13151
EN 13152
EN 13153
EN 13154
EN 13155
EN 13156
EN 13157
EN 13158
EN 13159
EN 13160
EN 13161
EN 13162
EN 13163
EN 13164
EN 13165
EN 13166
EN 13167
EN 13168
EN 13169
EN 13170
EN 13171
EN 13172
EN 13173
EN 13174
EN 13175
EN 13176
EN 13177
EN 13178
EN 13179
EN 13180
EN 13181
EN 13182
EN 13183
EN 13184
EN 13185
EN 13186
EN 13187
EN 13188
EN 13189
EN 13190
EN 13191
EN 13192
EN 13193
EN 13194
EN 13195
EN 13196
EN 13197
EN 13198
EN 13199
EN 13200
EN 13201
EN 13202
EN 13203
EN 13204
EN 13205
EN 13206
EN 13207
EN 13208
EN 13209
EN 13210
EN 13211
EN 13212
EN 13213
EN 13214
EN 13215
EN 13216
EN 13217
EN 13218
EN 13219
EN 13220
EN 13221
EN 13222
EN 13223
EN 13224
EN 13225
EN 13226
EN 13227
EN 13228
EN 13229
EN 13230
EN 13231
EN 13232
EN 13233
EN 13234
EN 13235
EN 13236
EN 13237
EN 13238
EN 13239
EN 13240
EN 13241
EN 13242
EN 13243
EN 13244
EN 13245
EN 13246
EN 13247
EN 13248
EN 13249
EN 13250
EN 13251
EN 13252
EN 13253
EN 13254
EN 13255
EN 13256
EN 13257
EN 13258
EN 13259
EN 13260
EN 13261
EN 13262
EN 13263
EN 13264
EN 13265
EN 13266
EN 13267
EN 13268
EN 13269
EN 13270
EN 13271
EN 13272
EN 13273
EN 13274
EN 13275
EN 13276
EN 13277
EN 13278
EN 13279
EN 13280
EN 13281
EN 13282
EN 13283
EN 13284
EN 13285
EN 13286
EN 13287
EN 13288
EN 13289
EN 13290
EN 13291
EN 13292
EN 13293
EN 13294
EN 13295
EN 13296
EN 13297
EN 13298
EN 13299
EN 13300
EN 13301
EN 13302
EN 13303
EN 13304
EN 13305
EN 13306
EN 13307
EN 13308
EN 13309
EN 13310
EN 13311
EN 13312
EN 13313
EN 13314
EN 13315
EN 13316
EN 13317
EN 13318
EN 13319
EN 13320
EN 13321
EN 13322
EN 13323
EN 13324
EN 13325
EN 13326
EN 13327
EN 13328
EN 13329
EN 13330
EN 13331
EN 13332
EN 13333
EN 13334
EN 13335
EN 13336
EN 13337
EN 13338
EN 13339
EN 13340
EN 13341
EN 13342
EN 13343
EN 13344
EN 13345
EN 13346
EN 13347
EN 13348
EN 13349
EN 13350
EN 13351
EN 13352
EN 13353
EN 13354
EN 13355
EN 13356
EN 13357
EN 13358
EN 13359
EN 13360
EN 13361
EN 13362
EN 13363
EN 13364
EN 13365
EN 13366
EN 13367
EN 13368
EN 13369
EN 13370
EN 13371
EN 13372
EN 13373
EN 13374
EN 13375
EN 13376
EN 13377
EN 13378
EN 13379
EN 13380
EN 13381
EN 13382
EN 13383
EN 13384
EN 13385
EN 13386
EN 13387
EN 13388
EN 13389
EN 13390
EN 13391
EN 13392
EN 13393
EN 13394
EN 13395
EN 13396
EN 13397
EN 13398
EN 13399
EN 13400
EN 13401
EN 13402
EN 13403
EN 13404
EN 13405
EN 13406
EN 13407
EN 13408
EN 13409
EN 13410
EN 13411
EN 13412
EN 13413
EN 13414
EN 13415
EN 13416
EN 13417
EN 13418
EN 13419
EN 13420
EN 13421
EN 13422
EN 13423
EN 13424
EN 13425
EN 13426
EN 13427
EN 13428
EN 13429
EN 13430
EN 13431
EN 13432
EN 13433
EN 13434
EN 13435
EN 13436
EN 13437
EN 13438
EN 13439
EN 13440
EN 13441
EN 13442
EN 13443
EN 13444
EN 13445
EN 13446
EN 13447
EN 13448
EN 13449
EN 13450
EN 13451
EN 13452
EN 13453
EN 13454
EN 13455
EN 13456
EN 13457
EN 13458
EN 13459
EN 13460
EN 13461
EN 13462
EN 13463
EN 13464
EN 13465
EN 13466
EN 13467
EN 13468
EN 13469
EN 13470
EN 13471
EN 13472
EN 13473
EN 13474
EN 13475
EN 13476
EN 13477
EN 13478
EN 13479
EN 13480
EN 13481
EN 13482
EN 13483
EN 13484
EN 13485
EN 13486
EN 13487
EN 13488
EN 13489
EN 13490
EN 13491
EN 13492
EN 13493
EN 13494
EN 13495
EN 13496
EN 13497
EN 13498
EN 13499
EN 13500
EN 13501
EN 13502
EN 13503
EN 13504
EN 13505
EN 13506
EN 13507
EN 13508
EN 13509
EN 13510
EN 13511
EN 13512
EN 13513
EN 13514
EN 13515
EN 13516
EN 13517
EN 13518

AXORTM

KOMFORT LINE K-3

Hinges

AXOR



Corner bearing

Hinges

Corner bearing 3x3

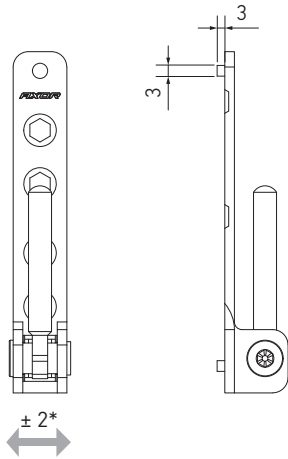

- maximum tilting of pin inclination - 180 deg.;
- for appropriate sash hinge look at p. 15;
- for decorative covers in other colors look at p. 27.

* horizontal adjustment, mm

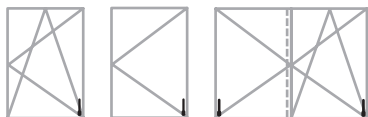

Covers of corner bearing

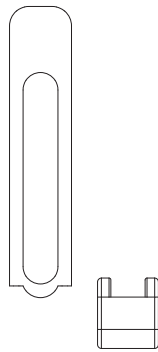

Sash overlap	Size "A"
18	18,5
20	20,5
21	21,5

The groove for glazing bead

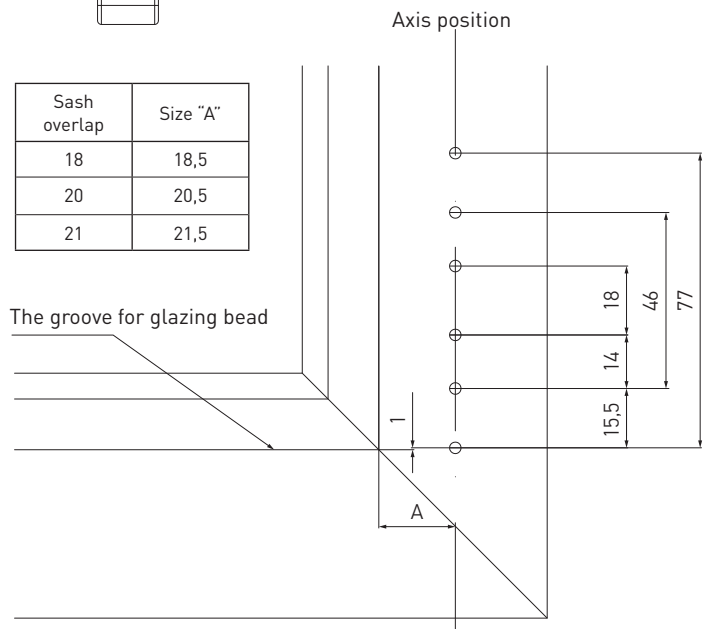

Description	Side opening	A	C	B	kg			Part No.
Corner bearing 3x3	L/R	12	—	—	100	4 / 3,9x40*	250	A5002-00-N03
Description	Side opening	A	C	B	kg			Part No.
Drilling jig for frame hinges	L/R	12	20	—	—	∅3	50	A7002-00-N09
Drilling jig for frame hinges	L/R	12	21	—	—	∅3	50	A7002-20-N09
Description	Side opening	A	C	B	kg			Part No.
Bottom cover of corner bearing	L/R	—	—	—	—	—	500	A7007-10-N**
Top cover of corner bearing	L/R	—	—	—	—	—	500	A7008-10-N**

A - sash rebate gap / C - sash overlap / B - sash groove position

* - quantity/size

** - for decorative covers in other colors look at p. 27



Corner bearing

Hinges

Corner bearing 6x22

Covers of corner bearing

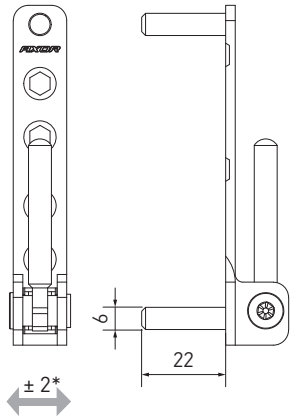

- maximum tilting of pin inclination - 180 deg.;
- for appropriate sash hinge look at p. 17;
- for decorative covers in other colors look at p. 27.

* horizontal adjustment, mm

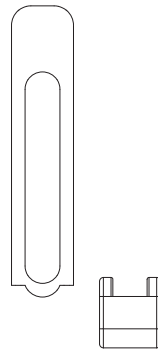
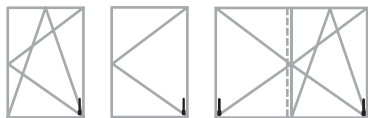

Sash overlap	Size "A"
18	18,5
20	20,5
21	21,5

The groove for glazing bead

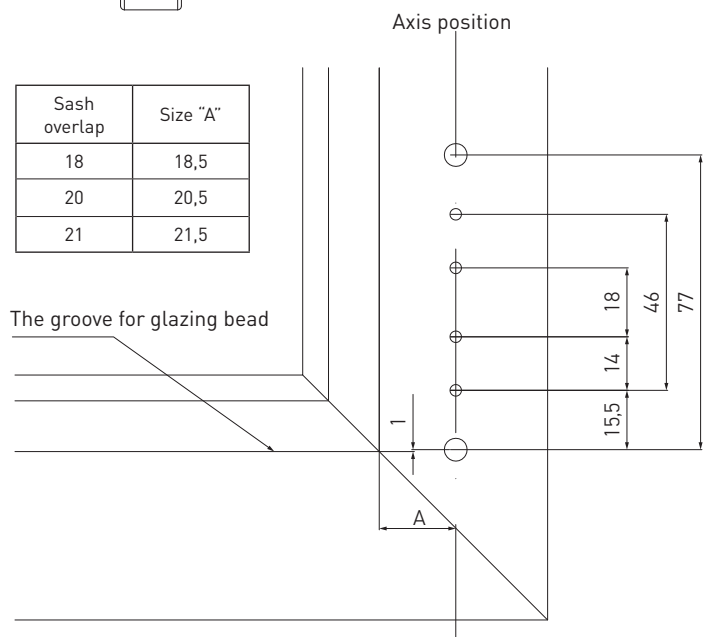

Description	Side opening	A	C	B	kg			Part No.
Corner bearing 6x22 130 kg	L/R	12	—	—	130	4 / 3,9x40	250	A5004-00-N03
Description	Side opening	A	C	B	kg			Part No.
Drilling jig for frame hinges	L/R	12	20	—	—	Ø3/6	50	A7002-10-N09
Drilling jig for frame hinges	L/R	12	21	—	—	Ø3/6	50	A7002-30-N09
Description	Side opening	A	C	B	kg			Part No.
Bottom cover of corner bearing	L/R	—	—	—	—	—	500	A7007-10-N**
Top cover of corner bearing	L/R	—	—	—	—	—	500	A7008-10-N**

A - sash rebate gap / C - sash overlap / B - sash groove position
 ** - for decorative covers in other colors look at p. 27



Corner bearing

Hinges

Corner bearing, 100 kg,
with installation on mullion

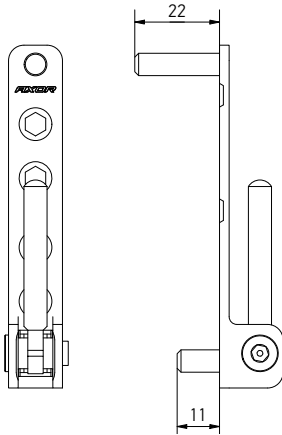

- maximum tilting of pin inclination - 180 deg.;
- for appropriate sash hinge look at p. 18;
- or decorative covers in other colors look at p. 27.

* horizontal adjustment, mm

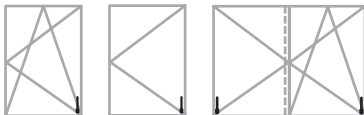

Covers of corner bearing

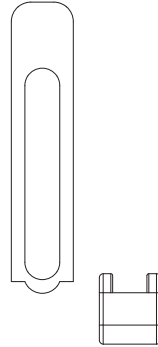

Sash overlap	Size "A"
18	18,5
20	20,5
21	21,5

The groove for glazing bead

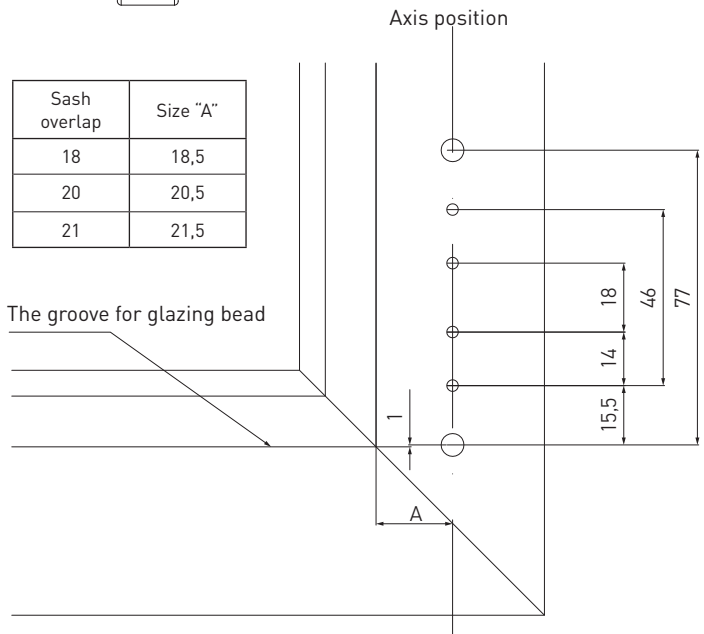

Description	Side opening	A	C	B	kg			Part No.
Corner bearing, 100 kg, with installation on mullion	L/R	12	—	—	100	4 / 3,9x40	250	A5045-00-N03
Description	Side opening	A	C	B	kg			Part No.
Drilling jig for frame hinges	L/R	12	20	—	—	Ø3/6	50	A7002-10-N09
Drilling jig for frame hinges	L/R	12	21	—	—	Ø3/6	50	A7002-30-N09
Description	Side opening	A	C	B	kg			Part No.
Bottom cover of corner bearing	L/R	—	—	—	—	—	500	A7007-10-N**
Top cover of corner bearing	L/R	—	—	—	—	—	500	A7008-10-N**

A - sash rebate gap / C - sash overlap / B - sash groove position
** - for decorative covers in other colors look at p. 27



Drill-in corner hinge

Hinges

Drill-in corner hinge

Cover of the drill-in corner hinge

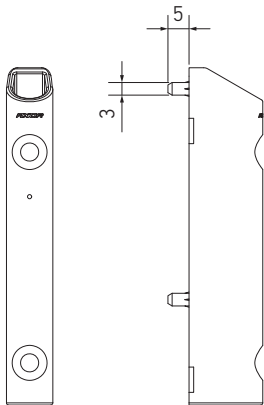

- used for 18-22 mm sash overlap;
- for appropriate sash hinge look at p. 13;
- for decorative covers in other colors look at p. 27.

* vertical adjustment, mm

Axis of sash groove position

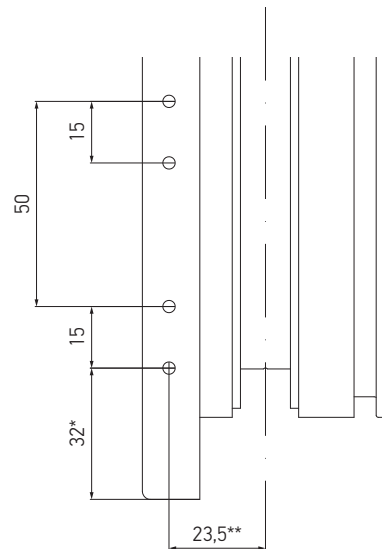

- * for 20-mm sash overlap
- ** for 13-mm sash groove position

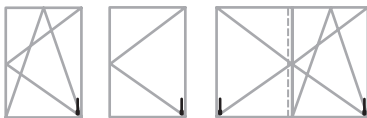

Description	Side opening	A	C	B	kg			Part No.
Drill-in corner hinge 3x5	L/R	—	—	—	100	2 / 4x40	250	A5003-00-N03
Description	Side opening	A	C	B	kg			Part No.
Drilling jig for sash hinges	L/R	12	20	13/9	—	∅3	80	A7003-00-N09
Drilling jig for sash hinges	L/R	12	21	13/9	—	∅3	80	A7003-20-N09
Description	Side opening	A	C	B	kg			Part No.
Cover of the drill-in corner hinge	L/R	—	—	—	—	—	500	A7006-10-N**

A - sash rebate gap / C - sash overlap / B - sash groove position
 ** - for decorative covers in other colors look at p. 27



Drill-in corner hinge

Hinges

Drill-in corner hinge
with gasket pressure adjustment

Cover of the drill-in corner hinge

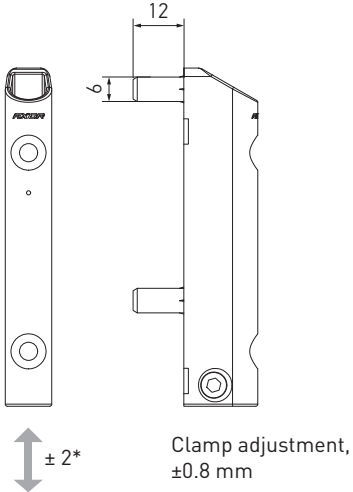

- used for 18-22 mm sash overlap;
- for appropriate sash hinge look at p. 13, 14;
- for decorative covers in other colors look at p. 27.

* vertical adjustment, mm

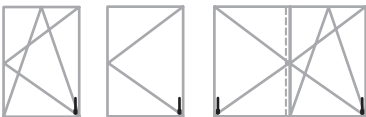

Axis of sash groove position

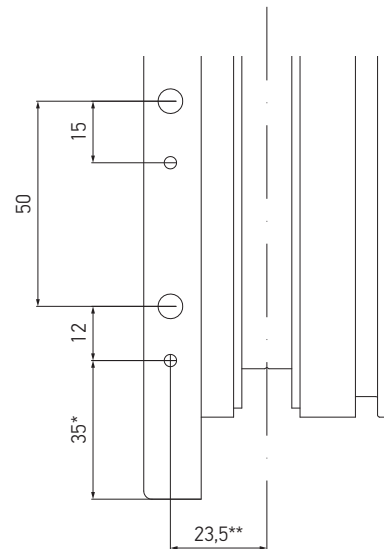

- * for 20-mm sash overlap
- ** for 13-mm sash groove position

Description	Side opening	A	C	B	kg			Part No.
Drill-in corner hinge AD 6x12	L/R	—	—	—	100	2 / 4x40	250	A5007-00-N03
Description	Side opening	A	C	B	kg			Part No.
Drilling jig for sash hinges AD	L/R	12	20	13/9	—	∅3/6	80	A7003-10-N09
Drilling jig for sash hinges AD	L/R	12	21	13/9	—	∅3/6	80	A7003-30-N09
Description	Side opening	A	C	B	kg			Part No.
Cover of the drill-in corner hinge	L/R	—	—	—	—	—	500	A7006-10-N**

A - sash rebate gap / C - sash overlap / B - sash groove position
** - for decorative covers in other colors look at p. 27



Drill-in corner hinge

Hinges

Drill-in corner hinge 6x16/26 with gasket pressure adjustment

Cover of the drill-in corner hinge

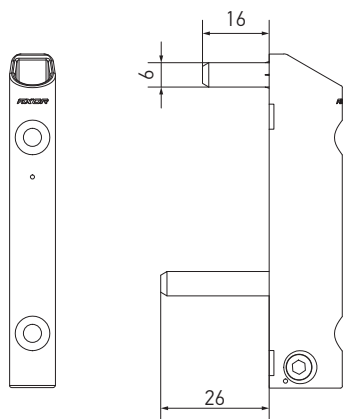

Clamp adjustment, ±0.8 mm

- used for 18-22 mm sash overlap;
- for appropriate sash hinge look at p. 14;
- for decorative covers in other colors look at p. 27.

* vertical adjustment, mm



Axis of sash groove position

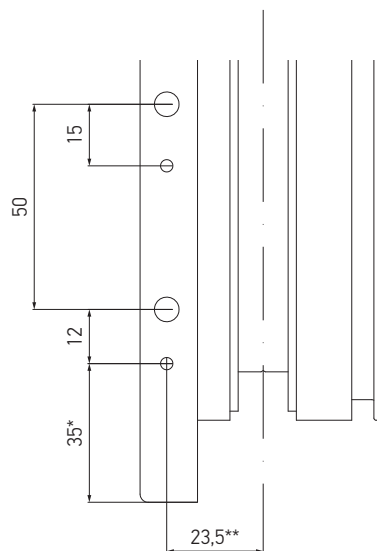

- * for 20-mm sash overlap
- ** for 13-mm sash groove position

Description	Side opening	A	C	B	kg			Part No.
Drill-in corner hinge AD 6x16/26	L/R	—	—	—	130	2 / 4x40	250	A5006-00-N03
Description	Side opening	A	C	B	kg			Part No.
Drilling jig for sash hinges AD	L/R	12	20	13/9	—	Ø3/6	80	A7003-10-N09
Drilling jig for sash hinges AD	L/R	12	21	13/9	—	Ø3/6	80	A7003-30-N09
Description	Side opening	A	C	B	kg			Part No.
Cover of the drill-in corner hinge	L/R	—	—	—	—	—	500	A7006-10-N**

A - sash rebate gap / C - sash overlap / B - sash groove position
 ** - for decorative covers in other colors look at p. 27



Drill-in corner hinge

Hinges

Drill-in corner hinge 6x16/26

Cover of the drill-in corner hinge

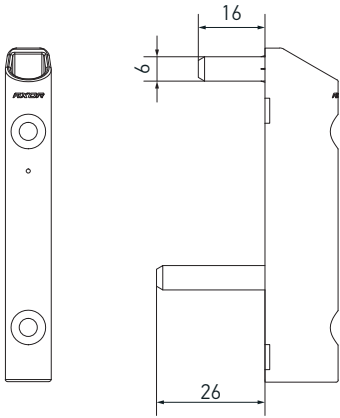

- used for 18-22 mm sash overlap;
- for appropriate sash hinge look at p. 13, 14;
- for decorative covers in other colors look at p. 27.

* vertical adjustment, mm

Axis of sash groove position

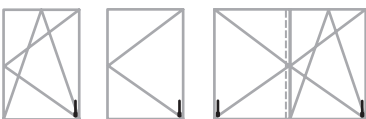
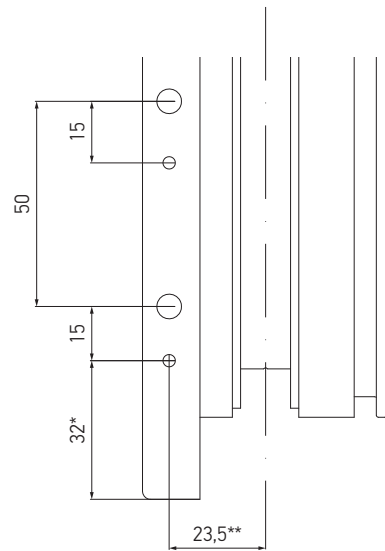

- * for 20-mm sash overlap
- ** for 13-mm sash groove position

Description	Side opening	A	C	B	kg			Part No.
Drill-in corner hinge 6x16/26	L/R	—	—	—	100	2 / 4x40	250	A5008-00-N03
Description	Side opening	A	C	B	kg			Part No.
Drilling jig for sash hinges	L/R	12	20	13/9	—	∅3/6	80	A7003-40-N09
Description	Side opening	A	C	B	kg			Part No.
Cover of the drill-in corner hinge	L/R	—	—	—	—	—	500	A7006-10-N**

A - sash rebate gap / C - sash overlap / B - sash groove position
 ** - for decorative covers in other colors look at p. 27



Rebate corner hinge

Hinges

Rebate corner hinge

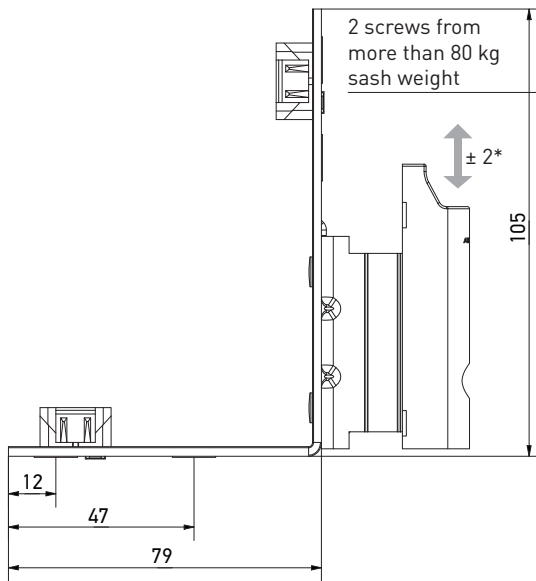

Cover of rebate corner hinge

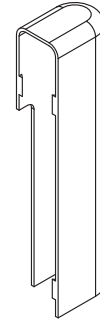
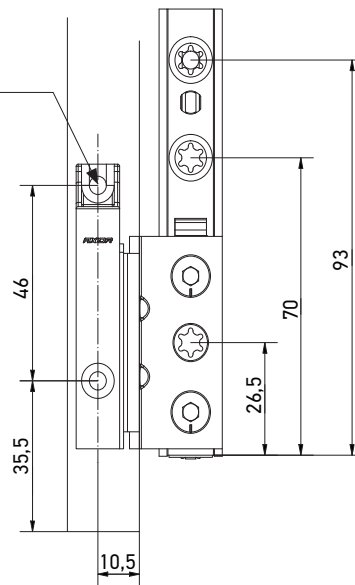

- used for 18, 20 mm sash overlap;
 - for appropriate sash hinge look at p. 13, 14;
 - for decorative covers in other colors look at p. 27.
- * vertical adjustment, mm

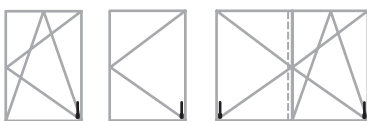

Description	Side opening	A	C	B	kg			Part No.
Rebate corner hinge 20/9 left/right	L/R	12	20	9	130	7	50	A5009-09-L/R03
Rebate corner hinge 18/9 left/right	L/R	12	18	9	130	7	50	A5010-09-L/R03
Rebate corner hinge 20/13 left/right	L/R	12	20	13	130	7	50	A5009-13-L/R03
Rebate corner hinge 18/13 left/right	L/R	12	18	13	130	7	50	A5010-13-L/R03
Cover of rebate corner hinge, left	L	—	—	—	—	—	500	A7009-00-L**
Cover of rebate corner hinge, right	R	—	—	—	—	—	500	A7009-00-R**

A - sash rebate gap / C - sash overlap / B - sash groove position
 ** - for decorative covers in other colors look at p. 27



Stay arm bearing

Hinges

Stay arm bearing

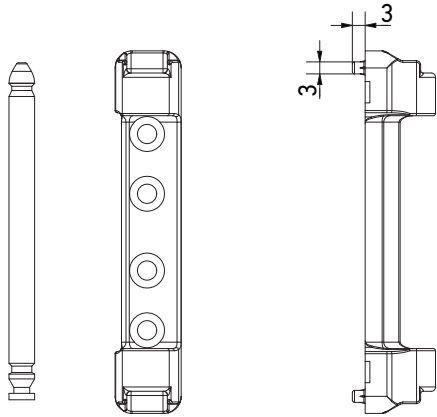

Cover of stay arm bearing



- for appropriate sash hinge look at p. 23;
- for decorative covers in other colors look at p. 27;
- the pin is supplied with hinge.

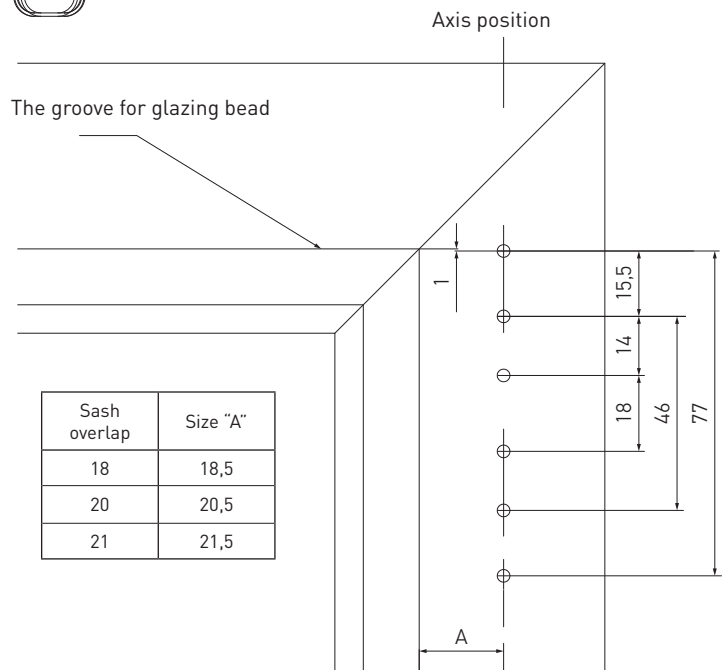

Sash overlap	Size "A"
18	18,5
20	20,5
21	21,5

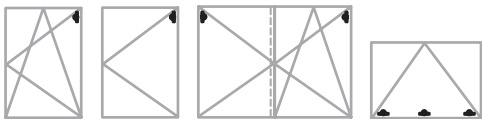

Description	Side opening	A	C	B	kg			Part No.
Stay arm bearing 3x3	L/R	12	—	—	100	4 / 3,9x40	250	A5001-00-N03
Description	Side opening	A	C	B	kg			Part No.
Drilling jig for frame hinges	L/R	12	20	—	—	∅3	50	A7002-00-N09
Drilling jig for frame hinges	L/R	12	21	—	—	∅3	50	A7002-20-N09
Description	Side opening	A	C	B	kg			Part No.
Cover of stay arm bearing	L/R	—	—	—	—	—	500	A7005-10-N**

A - sash rebate gap / C - sash overlap / B - sash groove position
 ** - for decorative covers in other colors look at p. 27



Stay arm bearing

Hinges

Stay arm bearing 6x12

Cover of stay arm bearing

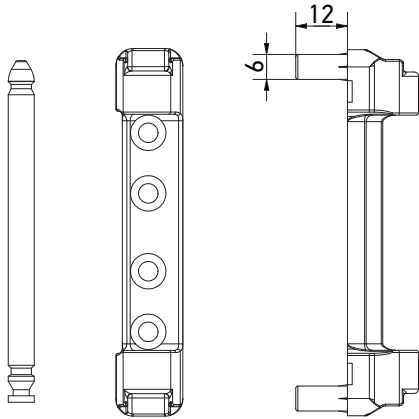

- for appropriate sash hinge look at p. 23;
- for decorative covers in other colors look at p. 27;
- the pin is supplied with hinge.

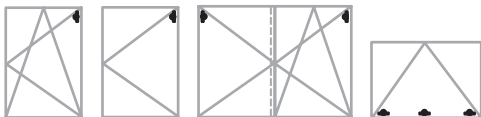
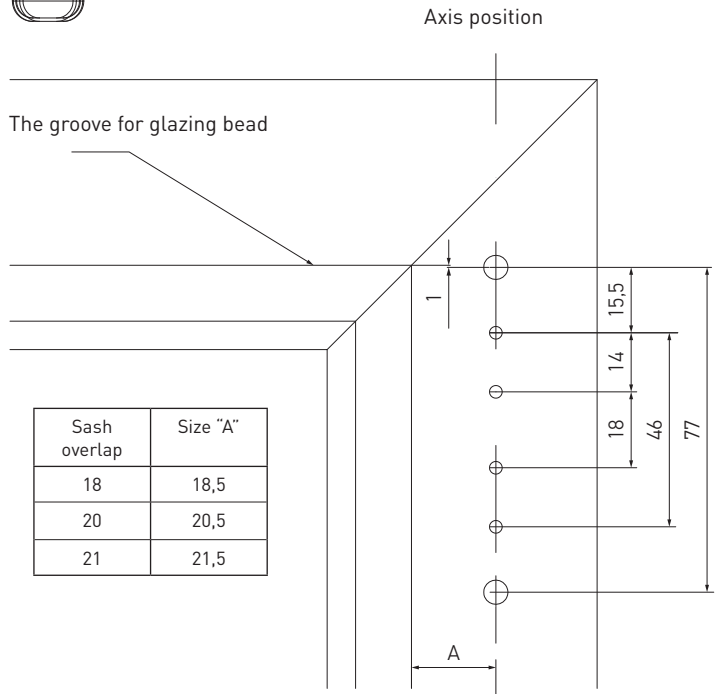

Description	Side opening	A	C	B	kg			Part No.
Stay arm bearing 6x12 mm	L/R	12	—	—	100	4 / 3,9x40	250	A5016-00-N03
Description	Side opening	A	C	B	kg			Part No.
Drilling jig for frame hinges	L/R	12	20	—	—	∅3/6	50	A7002-10-N09
Drilling jig for frame hinges	L/R	12	21	—	—	∅3/6	50	A7002-30-N09
Description	Side opening	A	C	B	kg			Part No.
Cover of stay arm bearing	L/R	—	—	—	—	—	500	A7005-10-N**

A - sash rebate gap / C - sash overlap / B - sash groove position
 ** - for decorative covers in other colors look at p. 27



Stay arm bearing

Hinges

Stay arm bearing 6x24

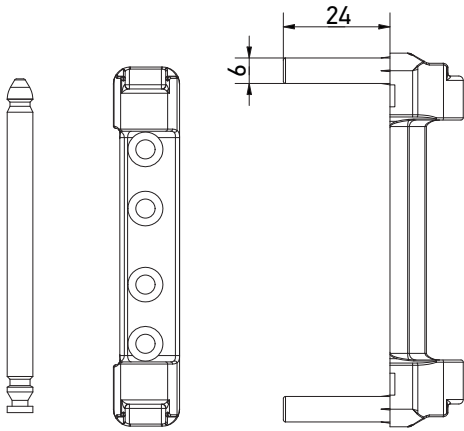

Cover of stay arm bearing



- for appropriate sash hinge look at p. 23;
- for decorative covers in other colors look at p. 27;
- the pin is supplied with hinge.

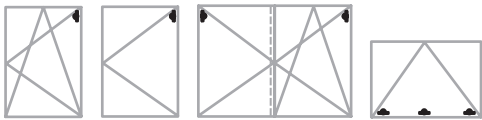
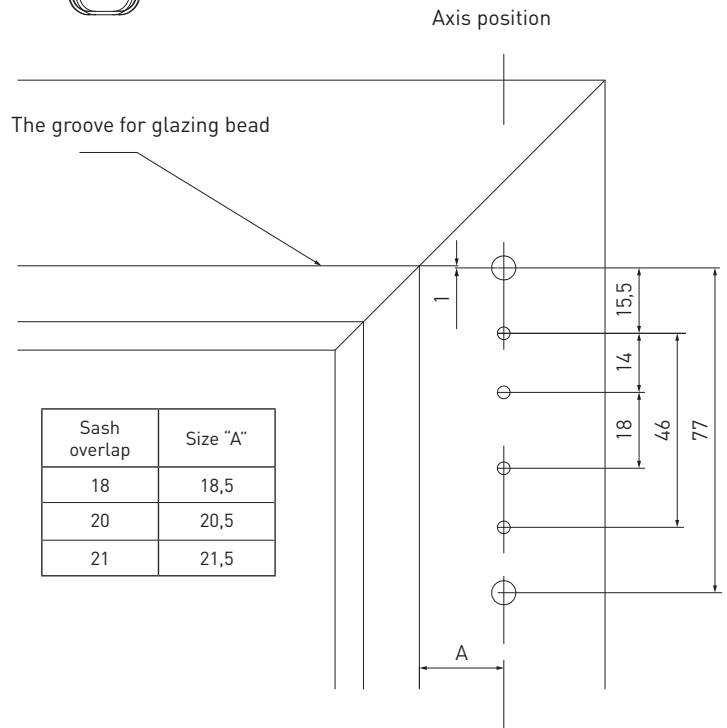

Description	Side opening	A	C	B	kg			Part No.
Stay arm bearing 6x24	L/R	12	—	—	130	4 / 3,9x40	250	A5005-00-N03
Description	Side opening	A	C	B	kg			Part No.
Drilling jig for frame hinges	L/R	12	20	—	—	∅3/6	50	A7002-10-N09
Drilling jig for frame hinges	L/R	12	21	—	—	∅3/6	50	A7002-30-N09
Description	Side opening	A	C	B	kg			Part No.
Cover of stay arm bearing	L/R	—	—	—	—	—	500	A7005-10-N**

A - sash rebate gap / C - sash overlap / B - sash groove position
 ** - for decorative covers in other colors look at p. 27



Top sash hinge

Hinges

Top sash hinge

Cover of top sash hinge

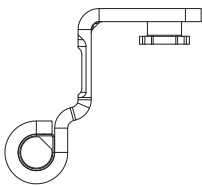
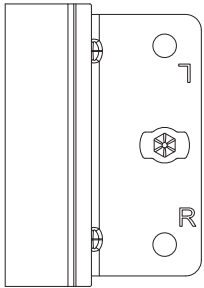

- for appropriate sash hinge look at p. 20-22;
- for decorative covers in other colors look at p. 27;
- installation with 4-mm hexagonal key.

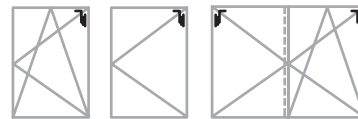

Description	Side opening	A	C	B	kg			Part No.
Top sash hinge 12/20-9	L/R	12	20	9	130	—	150	K5001-09-N03
Top sash hinge 12/20-10	L/R	12	20	9	130	—	150	K5001-10-N03
Top sash hinge 12/20-13	L/R	12	20	13	130	—	150	K5001-13-N03
Top sash hinge 12/20-14	L/R	12	20	13	130	—	150	K5001-14-N03
Top sash hinge 12/21-13	L/R	12	21	13	130	—	150	K5004-13-N03
Top sash hinge 12/18-09	L/R	12	18	9	130	—	150	K5006-09-N03
Top sash hinge 12/18-13	L/R	12	18	13	130	—	150	K5006-13-N03
Description	Side opening	A	C	B	kg			Part No.
Cover of top sash hinge	L/R	—	—	—	—	—	500	A7004-10-N**

A - sash rebate gap / C - sash overlap / B - sash groove position
 ** - for decorative covers in other colors look at p. 27



Bottom hinges for tilt sash

Hinges

Bottom hinges for tilt sash

Cover of top sash hinge

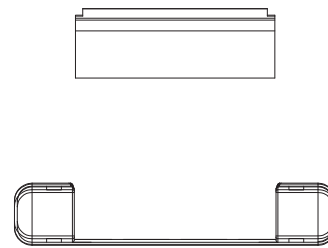
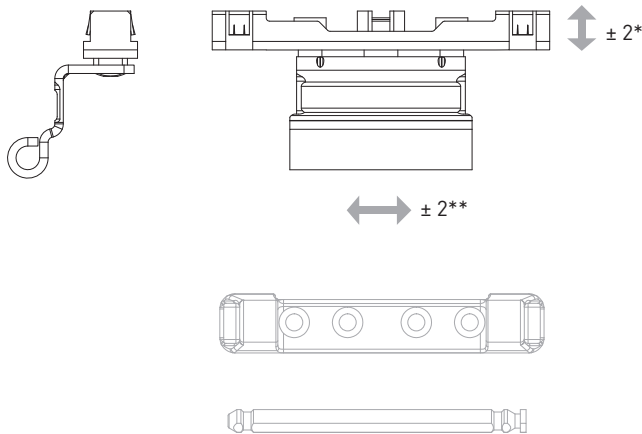

- * vertical adjustment, mm;
- ** horizontal adjustment, mm;
- *** ONLY FOR TILT SASH

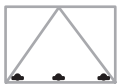

Description	Side opening	A	C	B	kg			Part No.
Bottom hinges for tilt sash 12/20-9	L/R	12	20	9	50*	2 / 4×25	100	A7014-09-N03
Bottom hinges for tilt sash 12/20-12	L/R	12	20	12	50*	2 / 4×25	100	A7014-12-N03
Bottom hinges for tilt sash 12/20-13	L/R	12	20	13	50*	2 / 4×25	100	A7014-13-N03
Bottom hinges for tilt sash 12/20-14	L/R	12	20	14	50*	2 / 4×25	100	A7014-14-N03
Description	Side opening	A	C	B	kg			Part No.
Cover of top sash hinge	L/R	—	—	—	—	—	500	A7004-10-N**

A - sash rebate gap / C - sash overlap / B - sash groove position
 * - for 2-hinges set
 ** - for decorative covers in other colors look at p. 27



Middle hinge

Hinges

Middle hinge

Cover of top sash hinge

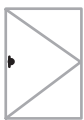
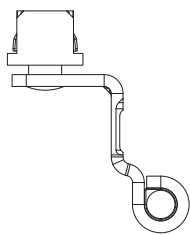
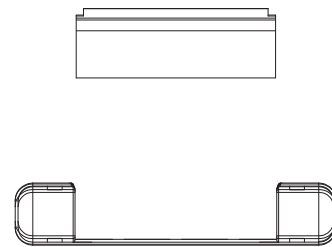
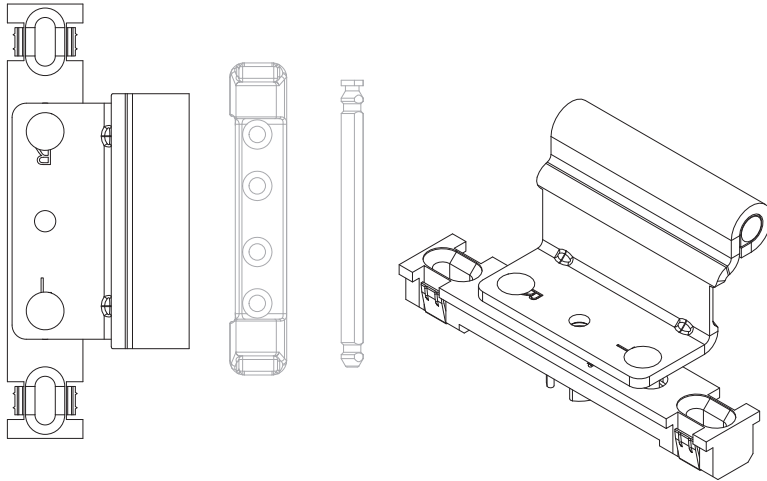

Description	SRH (mm)		A	C	B	kg			Part No.
Middle hinge 12/20-9	751-1710	1	12	20	9	50*	2 / 4x25	100	A7030-09-N03
	1711-2360	2							
Middle hinge 12/20-12	751-1710	1	12	20	12	50*	2 / 4x25	100	A7030-12-N03
	1711-2360	2							
Middle hinge 12/20-13	751-1710	1	12	20	13	50*	2 / 4x25	100	A7030-13-N03
	1711-2360	2							
Middle hinge 12/20-14	751-1710	1	12	20	14	50*	2 / 4x25	100	A7030-14-N03
	1711-2360	2							
Description	SRH (mm)		A	C	B	kg			Part No.
Cover of top sash hinge	751-1710	1	—	—	—	—	—	500	A7004-10-N**
	1711-2360	2	—	—	—	—	—		

A - sash rebate gap / C - sash overlap / B - sash groove position
* - for 2-hinges set

** - for decorative covers in other colors look at p. 27

Covers
Hinges

Description	Sketch	Color		Part No.
Cover of top sash hinge		White RAL 9016	500	A7004-10-N01
		Brown RAL 8022	500	A7004-10-N02
		Silver F1	500	A7004-10-N03
		Cream RAL 9001	500	A7004-10-N04
		Gold F3	500	A7004-10-N05
		Bronze F4	500	A7004-10-N06
		Black RAL 9005	500	A7004-10-N07
Cover of stay arm bearing		White RAL 9016	500	A7005-10-N01
		Brown RAL 8022	500	A7005-10-N02
		Silver F1	500	A7005-10-N03
		Cream RAL 9001	500	A7005-10-N04
		Gold F3	500	A7005-10-N05
		Bronze F4	500	A7005-10-N06
		Black RAL 9005	500	A7005-10-N07
Cover of the drill-in corner hinge		White RAL 9016	500	A7006-10-N01
		Brown RAL 8022	500	A7006-10-N02
		Silver F1	500	A7006-10-N03
		Cream RAL 9001	500	A7006-10-N04
		Gold F3	500	A7006-10-N05
		Bronze F4	500	A7006-10-N06
		Black RAL 9005	500	A7006-10-N07
Bottom cover of corner bearing		White RAL 9016	500	A7007-10-N01
		Brown RAL 8022	500	A7007-10-N02
		Silver F1	500	A7007-10-N03
		Cream RAL 9001	500	A7007-10-N04
		Gold F3	500	A7007-10-N05
		Bronze F4	500	A7007-10-N06
		Black RAL 9005	500	A7007-10-N07
Top cover of corner bearing		White RAL 9016	500	A7008-10-N01
		Brown RAL 8022	500	A7008-10-N02
		Silver F1	500	A7008-10-N03
		Cream RAL 9001	500	A7008-10-N04
		Gold F3	500	A7008-10-N05
		Bronze F4	500	A7008-10-N06
		Black RAL 9005	500	A7008-10-N07
Cover of rebate corner hinge		White RAL 9016	500	A7009-10-L01/R01
		Brown RAL 8022	500	A7009-10-L02/R02
		Silver F1	500	A7009-10-L03/R03
		Cream RAL 9001	500	A7009-10-L04/R04
		Gold F3	500	A7009-10-L05/R05
		Bronze F4	500	A7009-10-L06/R06
		Black RAL 9005	500	A7009-10-L07/R07

AXORTM

KOMFORT LINE K-3

Gears

AXOR



Drilling and milling a sash for 7.5-mm backset gear

Gears

Drilling and milling a sash for 7.5-mm backset gear

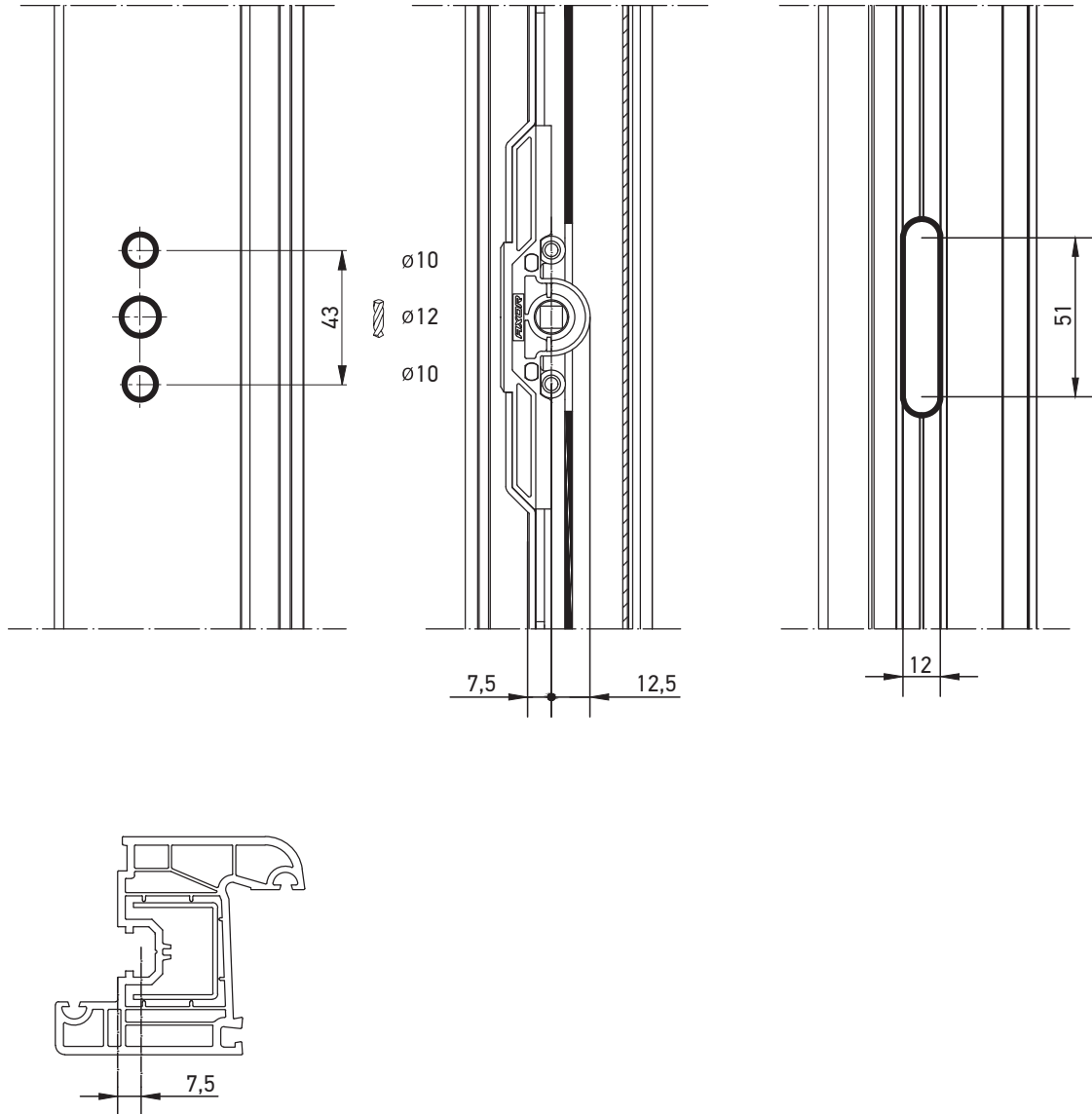



Drilling and milling a sash for 15-mm backset gear

Gears

Drilling and milling a sash for 15-mm backset gear

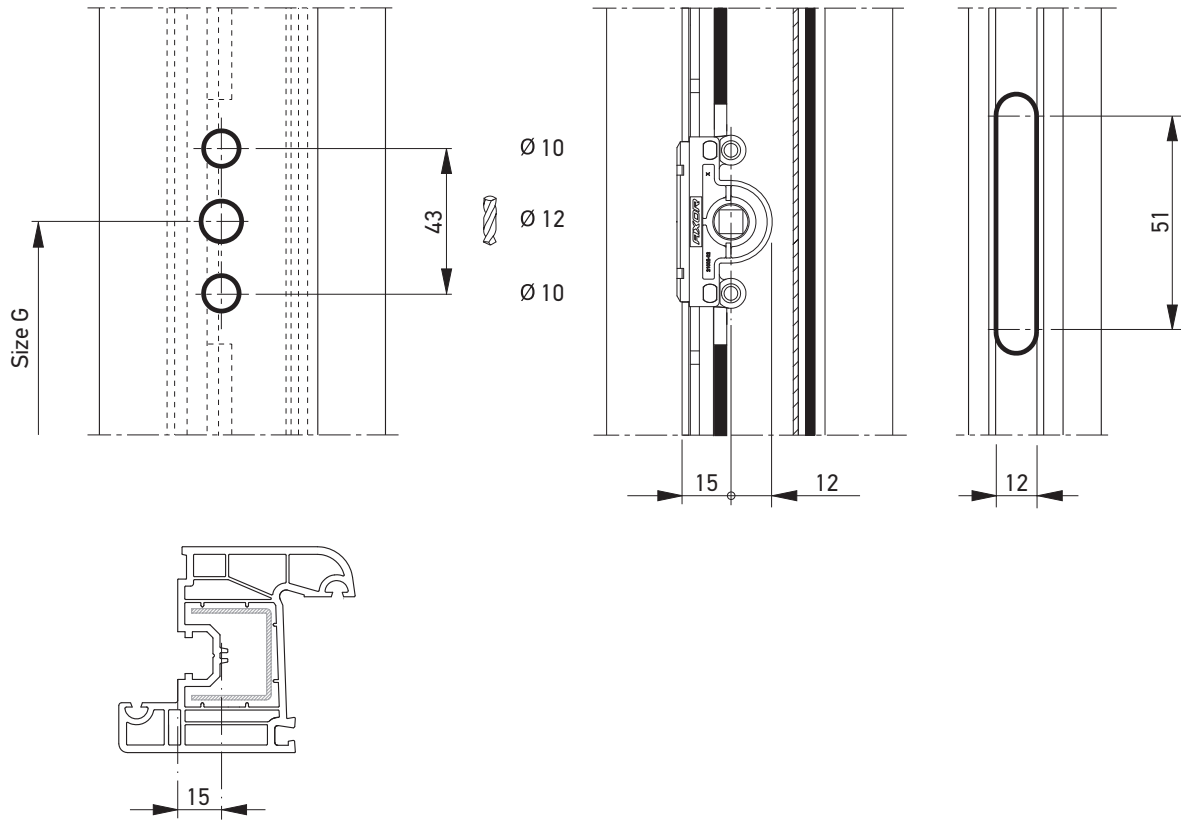



**Drilling and milling a sash
for 25, 30, 35-mm backset gear**

Gears

Drilling and milling a sash for 25, 30, 35-mm backset gear,
handle position is central

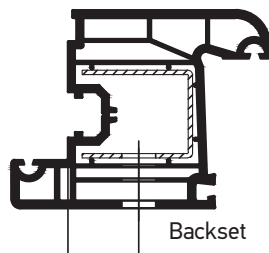
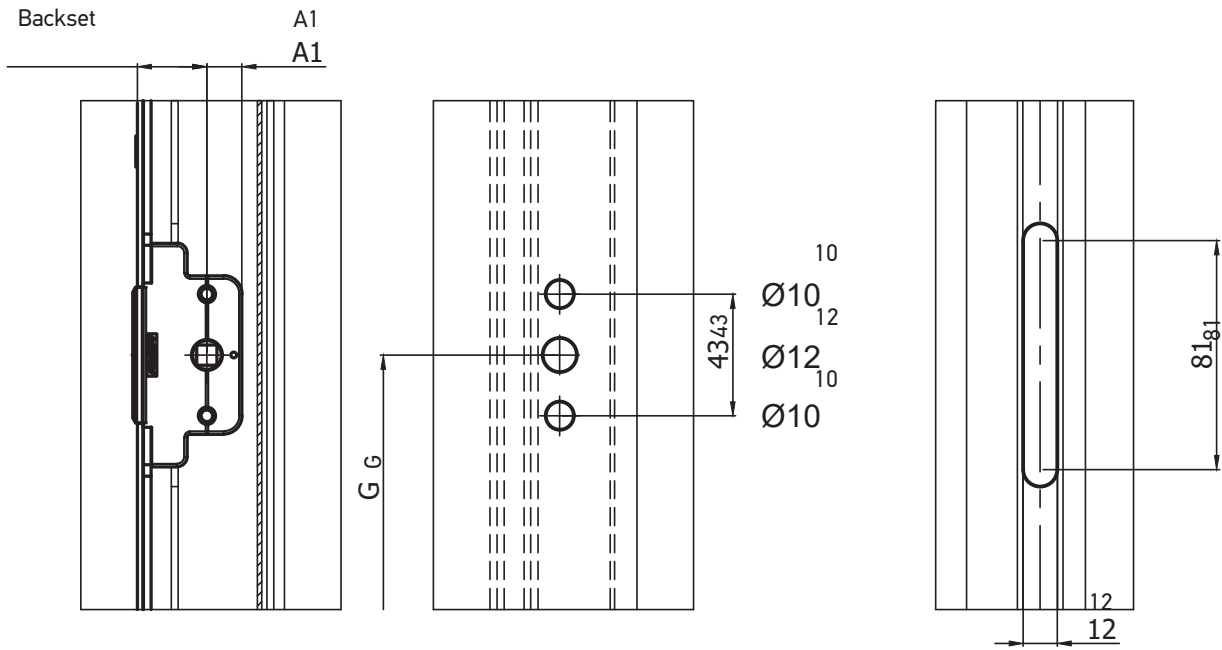

Backset	A1, mm
25	12,4
30	12,4
35	12,4



Drilling and milling a sash for 25, 30, 35-mm backset gear

Gears

Drilling and milling a sash for 25, 30, 35-mm backset gear,
lockable, handle position is central

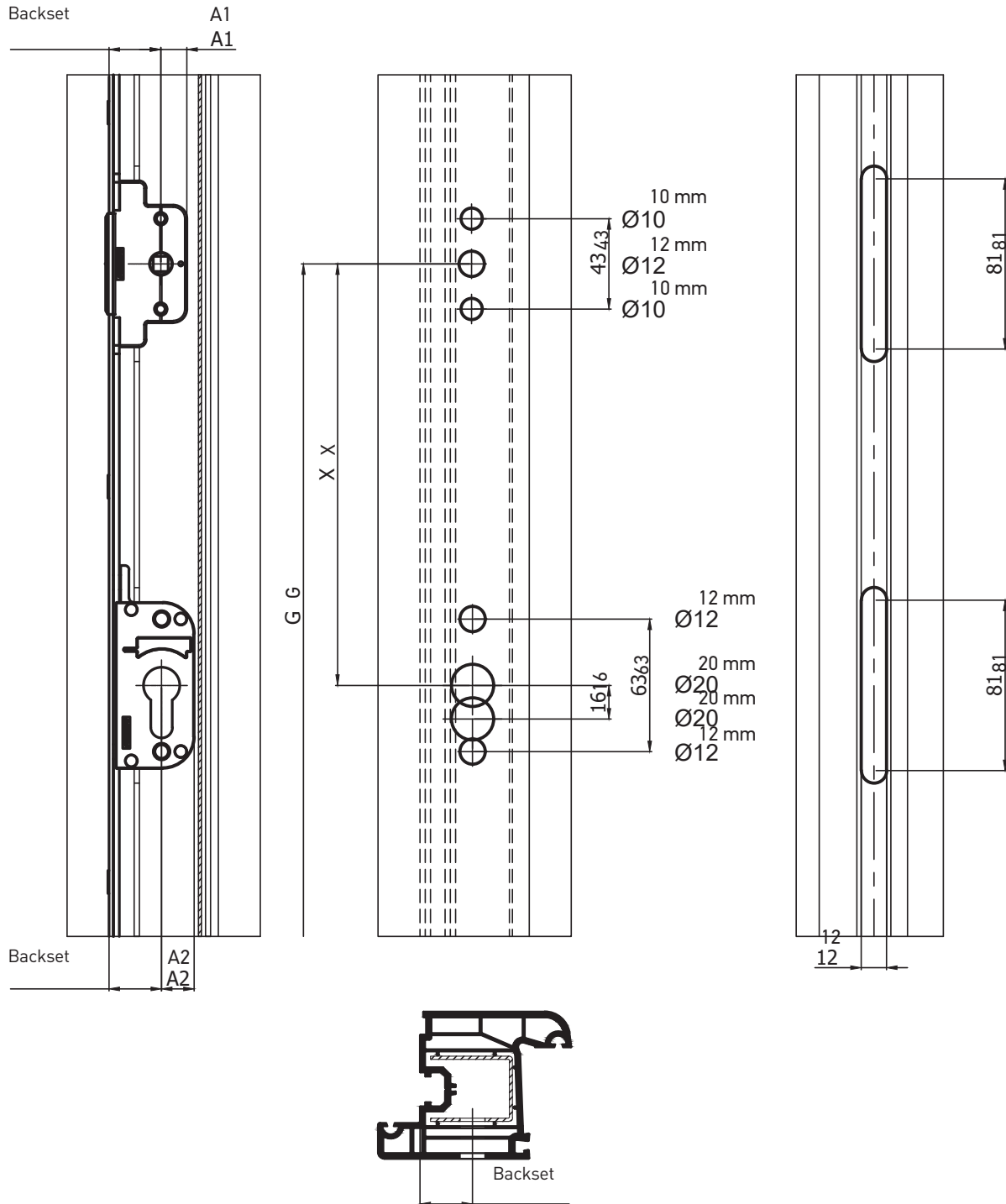

Backset	A1, mm	A2, mm
25	12,4	15,5
30	12,4	15,5
35	12,4	15,5

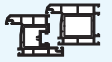

Drilling and milling a sash for sliding system gear for sliding system gear

Gears

Drilling and milling a sash for sliding system gear lockable, backset 15 mm.

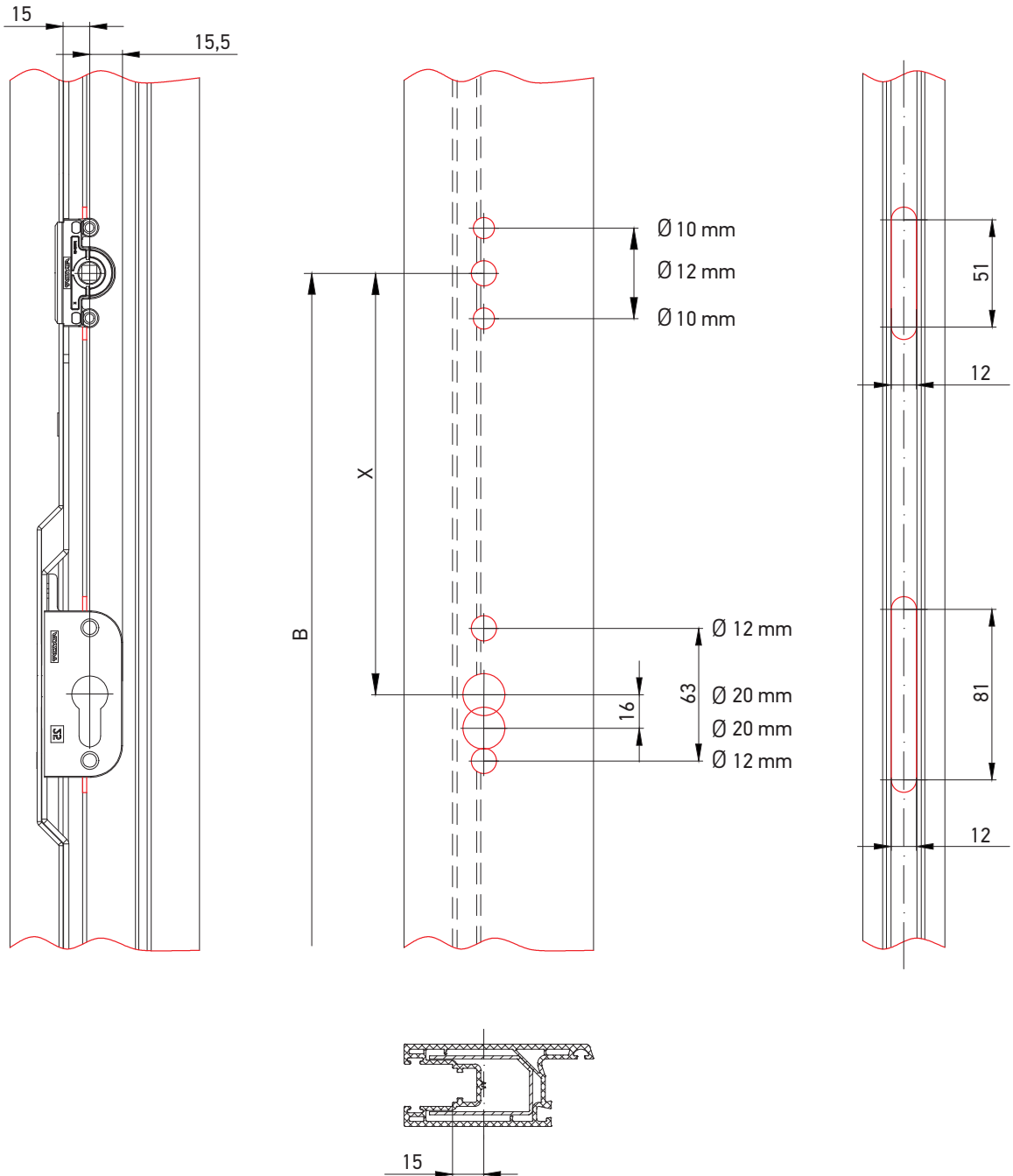



Tilt and turn variable gear

Gears

Tilt and turn variable gear, backset 15 mm.

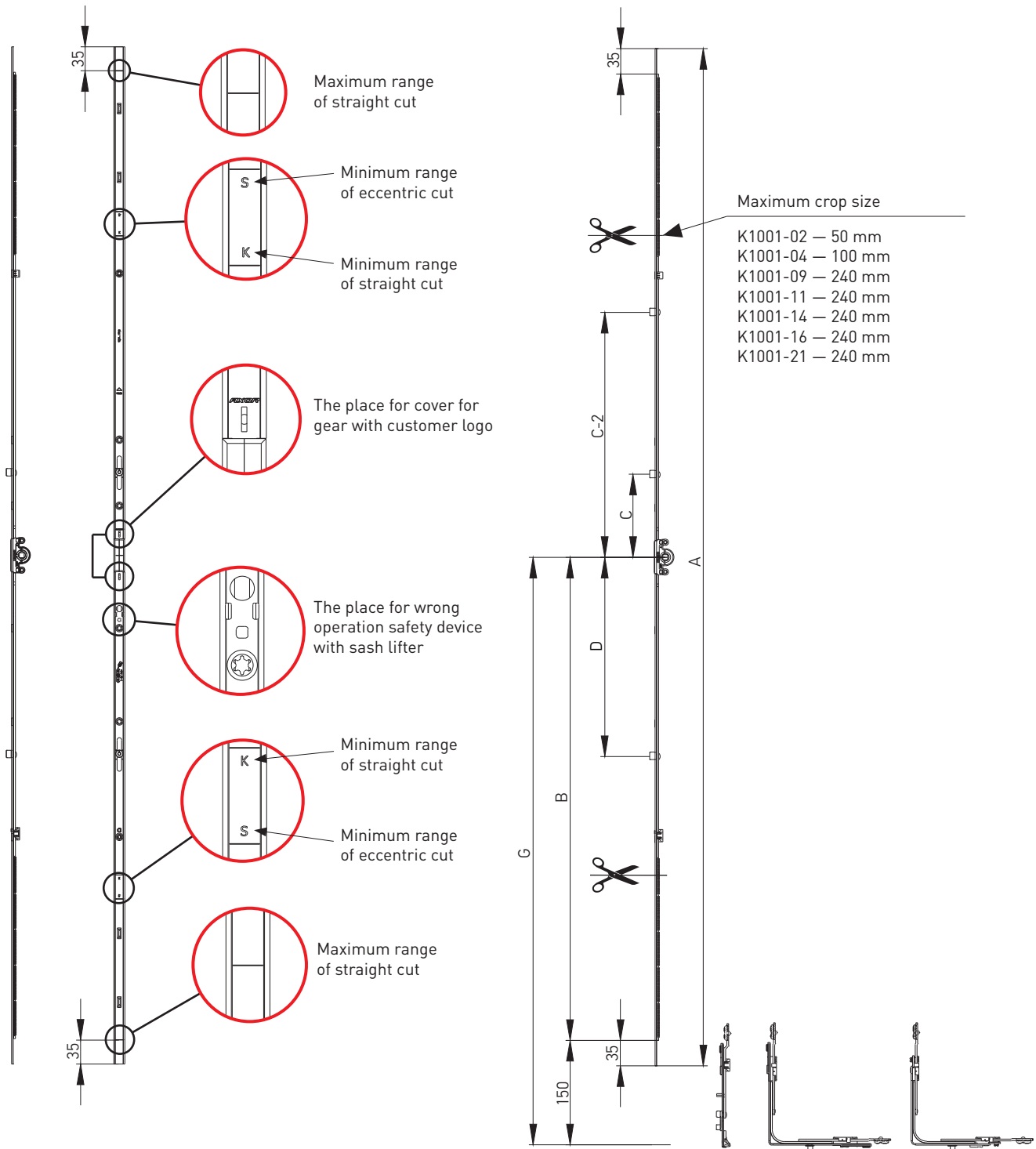

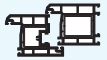

Tilt and turn variable gear

Gears

Description	SRH (mm)	Dimensions										Part No.
		G	A	B	C	C-2	D					
Tilt and turn variable gear 0, L=320, 450-550*	450-550	225-275	320	125	—	—	—	—	—	—	20	K1001-02-N03
Tilt and turn variable gear 1, L=520, 551-750*	551-750	275-375	520	225	—	—	—	—	—	2	20	K1001-04-N03
Tilt and turn variable gear 2, L=1000, 751-1230, 1 ML	751-1230	375-615	1000	465	120	—	—	1	—	4	20	K1001-09-N03
Tilt and turn variable gear 3, L=1200, 950-1430, 1 ML	950-1430	475-715	1200	565	120	—	—	1	—	5	20	K1001-11-N03
Tilt and turn variable gear 3A, L=1200, 950-1430, 2 ML	950-1430	475-715	1200	565	120	—	226	2	—	6	20	K1001-12-N03
Tilt and turn variable gear 4, L=1480, 1231-1710, 2 ML	1231-1710	615-855	1480	705	120	—	290	2	—	6	20	K1001-14-N03
Tilt and turn variable gear 5, L=1680, 1431-1910, 2 ML	1431-1910	715-955	1680	805	265	—	390	2	—	7	10	K1001-16-N03
Tilt and turn variable gear 6, L=2160, 1911-2390, 3 ML	1911-2390	955-1195	2160	1045	120	595	490	3	—	11	10	K1001-21-N03
Tilt and turn variable gear 2, L=1000, 751-1230, 1 MR	751-1230	375-615	1000	465	120	—	—	—	1	4	20	K1031-09-N03
Tilt and turn variable gear 3, L=1200, 950-1430, 1 MR	950-1430	475-715	1200	565	120	—	—	—	1	5	20	K1031-11-N03
Tilt and turn variable gear 3A, L=1200, 950-1430, 2 MR	950-1430	475-715	1200	565	120	—	226	—	2	6	20	K1031-12-N03
Tilt and turn variable gear 4, L=1480, 1231-1710, 2 MR	1231-1710	615-855	1480	705	120	—	290	—	2	6	20	K1031-14-N03
Tilt and turn variable gear 5, L=1680, 1431-1910, 2 MR	1431-1910	715-955	1680	805	265	—	390	—	2	7	10	K1031-16-N03
Tilt and turn variable gear 6, L=2160, 1911-2390, 3 MR	1911-2390	955-1195	2160	1045	120	595	490	—	3	11	10	K1031-21-N03

* there is not a place for the micro lift

- handle position is central;

- backset 15 mm.



Constant tilt & turn gear

Gears

Constant tilt & turn gear

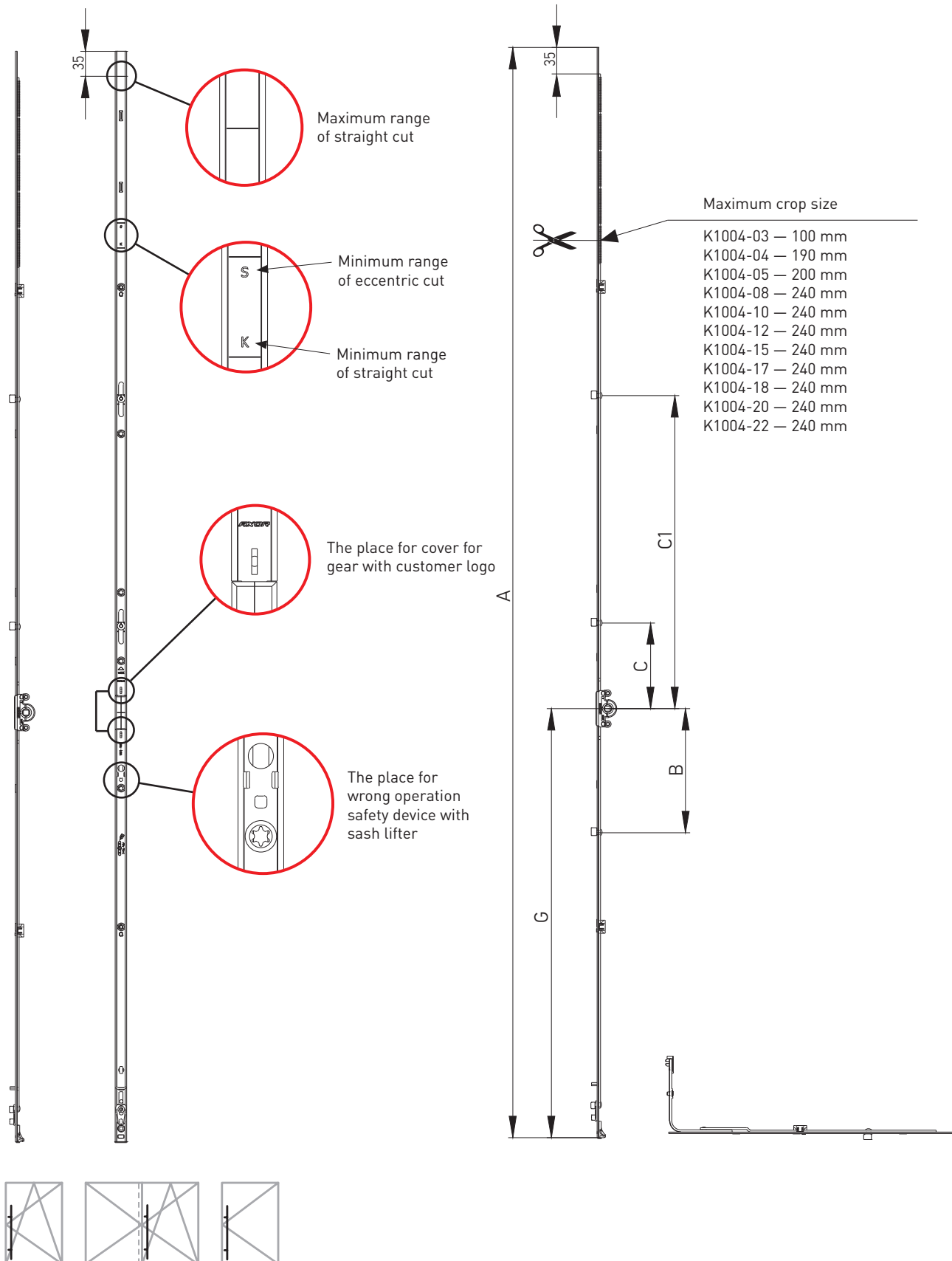



Constant tilt & turn gear

Gears

Description	SRH (mm)	Dimensions									Part No.
		G	A	B	C	C-1					
Constant gear 0**, L=435, 360-550	360-550	140	435	0	0	0	—	—	1	20	K1004-04-N03
Constant gear 1, L=385, G=175, 400-500*	400-500	175	385	—	—	—	—	—	2	20	K1004-03-N03
Constant gear 2, L=565, G=200, 480-680*	480-680	200	565	—	—	—	—	—	3	20	K1004-05-N03
Constant gear 3, L=805, G=300, 681-920, 1 ML	681-920	300	805	—	120	—	1	—	5	20	K1004-08-N03
Constant gear 4, L=1045, G=450, 921-1160, 1 ML	921-1160	450	1045	—	120	—	1	—	5	20	K1004-10-N03
Constant gear 5, L=1285, G=600, 1161-1400, 1 ML	1161-1400	600	1285	—	120	—	1	—	7	20	K1004-12-N03
Constant gear 6, L=1525, G=600, 1401-1640, 2 ML	1401-1640	600	1525	—	120	438	2	—	8	20	K1004-15-N03
Constant gear 7, L=1765, G=600, 1641-1880, 2 ML	1641-1880	600	1765	—	120	643	2	—	9	10	K1004-17-N03
Constant gear 8, L=1765, G=1000, 1641-1880, 2 ML	1641-1880	1000	1765	280	263	—	2	—	10	10	K1004-18-N03
Constant gear 9, L=2005, G=1000, 1881-2120, 2 ML	1881-2120	1000	2005	280	387	—	2	—	11	10	K1004-20-N03
Constant gear 10, L=2245, G=1000, 2121-2360, 3 ML	2120-2360	1000	2245	280	120	723	3	—	13	10	K1004-22-N03
Constant gear 3, L=805, G=300, 681-920, 1 MR	681-920	300	805	—	120	—	—	1	5	20	K1034-08-N03
Constant gear 4, L=1045, G=450, 921-1160, 1 MR	921-1160	450	1045	—	120	—	—	1	5	20	K1034-10-N03
Constant gear 5, L=1285, G=600, 1161-1400, 1 MR	1161-1400	600	1285	—	120	—	—	1	7	20	K1034-12-N03
Constant gear 6, L=1525, G=600, 1401-1640, 2 MR	1401-1640	600	1525	—	120	438	—	2	8	20	K1034-15-N03
Constant gear 7, L=1765, G=600, 1641-1880, 2 MR	1641-1880	600	1765	—	120	643	—	2	9	10	K1034-17-N03
Constant gear 8, L=1765, G=1000, 1641-1880, 2 MR	1641-1880	1000	1765	280	263	—	—	2	10	10	K1034-18-N03
Constant gear 9, L=2005, G=1000, 1881-2120, 2 MR	1881-2120	1000	2005	280	387	—	—	2	11	10	K1034-20-N03
Constant gear 10, L=2245, G=1000, 2121-2360, 3 MR	2120-2360	1000	2245	280	120	723	—	3	13	10	K1034-22-N03

* there is not a place for the micro lift;

**gear 0 can't be connected with middle lock;

- backset 15 mm.



Constant tilt & turn gear

Gears

Constant tilt & turn gear

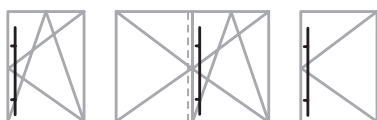
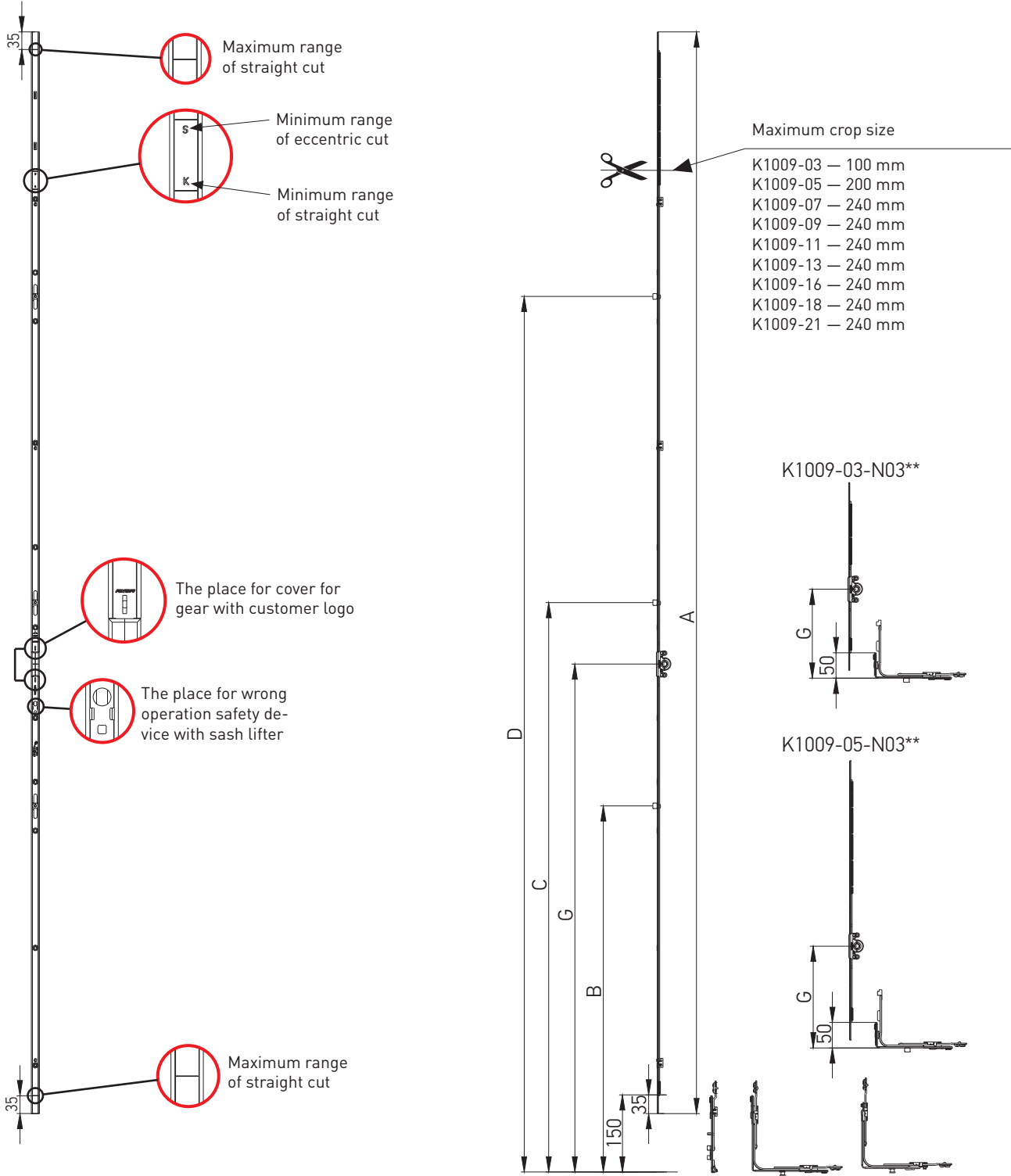



Constant tilt & turn gear

Gears

Description	SRH (mm)	Dimensions								Part No.
		G	A	B	C	D				
Constant gear 0**, L=370, 400-500	400-500	175	370	—	—	—	—	—	20	K1009-03-N03
Constant gear 1**, L=550, 480-680*	480-680	200	550	—	—	—	—	2	20	K1009-05-N03
Constant gear 2, L=690, 681-920*	681-920	300	690	—	431	—	1	3	20	K1009-07-N03
Constant gear 3, L=930, 921-1160	921-1160	450	930	—	571	—	1	4	20	K1009-09-N03
Constant gear 4, L=1170, 1161-1400	1161-1400	600	1170	—	721	—	1	6	20	K1009-11-N03
Constant gear 5, L=1410, 1401-1640	1401-1640	600	1410	—	721	1039	2	7	20	K1009-13-N03
Constant gear 6, L=1650, 1641-1880	1641-1880	600	1650	—	721	1244	2	8	10	K1009-16-N03
Constant gear 7, L=1650, 1641-1880	1641-1880	1000	1650	721	1264	—	2	8	10	K1009-17-N03
Constant gear 8, L=1890, 1881-2120	1881-2120	1000	1890	721	1388	—	2	9	10	K1009-18-N03
Constant gear 9, L=2130, 2121-2360	2121-2360	1000	2130	721	1121	1724	3	11	10	K1009-21-N03

* there is not a place for the micro lift;

** connecting with narrow corner transmission

- Backset 15 mm.



Constant tilt & turn gear

Gears

Constant tilt & turn gear

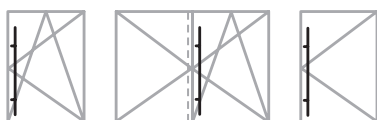
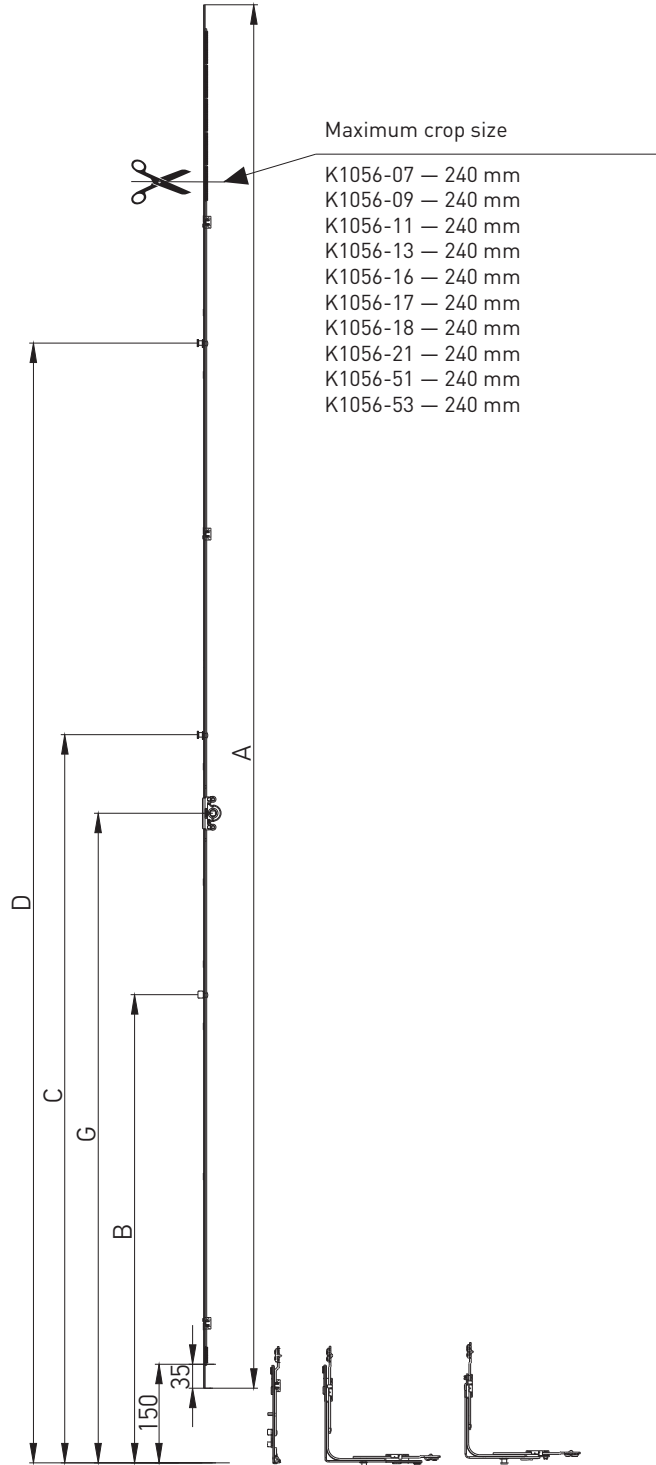
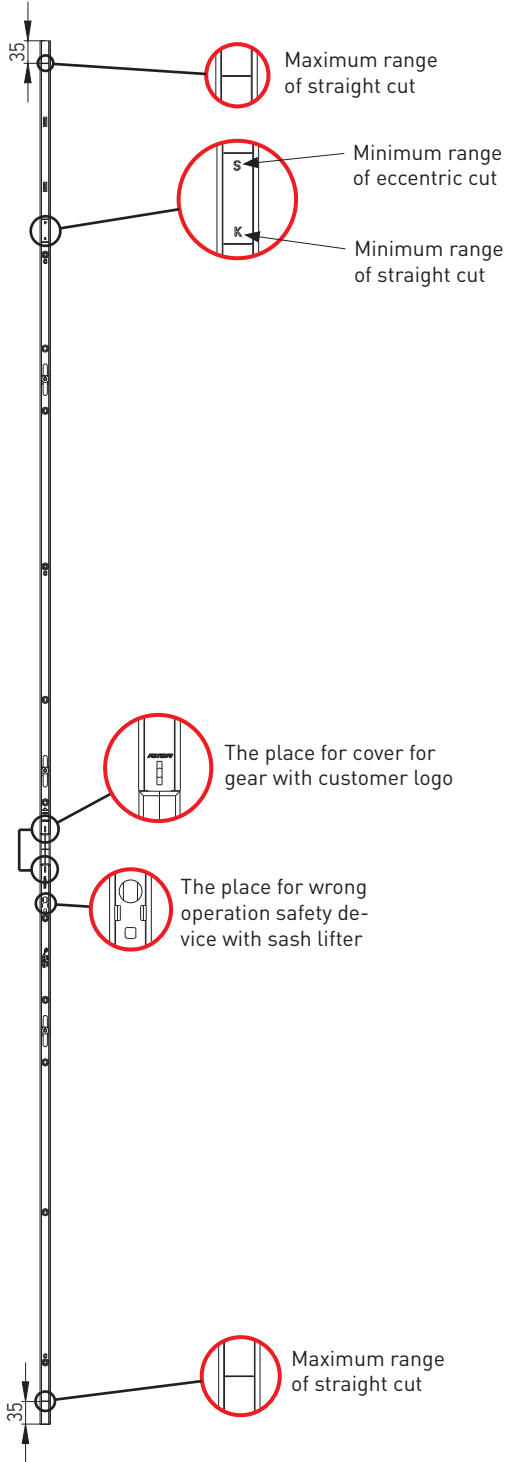

Constant tilt & turn gear
Gears

Description	SRH (mm)	Dimensions								Part No.
		G	A	B	C	D				
Constant gear 2 L=690, G=300, 681-920, MR*	681-920	300	690	—	431	—	1	3	20	K1056-07-N03
Constant gear 3, L=930, G=450, 921-1160, MR	921-1160	450	930	—	571	—	1	4	20	K1056-09-N03
Constant gear 4, L=1170, G=600, 1161-1400, MR	1161-1400	600	1170	—	721	—	1	6	20	K1056-11-N03
Constant gear 5, L=1410, G=600, 1401-1640, MR	1401-1640	600	1410	—	721	1039	2	7	20	K1056-13-N03
Constant gear 6, L=1650, G=600, 1641-1880, MR	1641-1880	600	1650	—	721	1244	2	8	10	K1056-16-N03
Constant gear 7, L=1650, G=1000, 1641-1880, MR	1641-1880	1000	1650	721	1264	—	2	8	10	K1056-17-N03
Constant gear 8, L=1890, G=1000, 1881-2120, MR	1881-2120	1000	1890	721	1388	—	2	9	10	K1056-18-N03
Constant gear 9, L=2130, G=1000, 2121-2360, MR	2121-2360	1000	2130	721	1121	1724	3	11	10	K1056-21-N03
Constant gear, L=1170, G=500, 1161-1400, 1 MR with the option of connecting to acorner transmission	1161-1400	500	1170	—	721	—	1	6	20	K1056-51-N03
Constant gear L=1410, G=500, 1401-1640, 2 MR with the option of connecting to acorner transmission	1401-1640	500	1410	—	721	1039	2	7	20	K1056-53-N03

* there is not a place for the micro lift;

- Backset 15 mm.



Constant tilt & turn gear

Gears

Constant tilt & turn gear

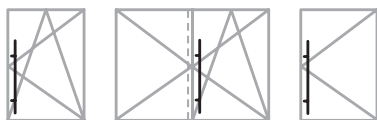
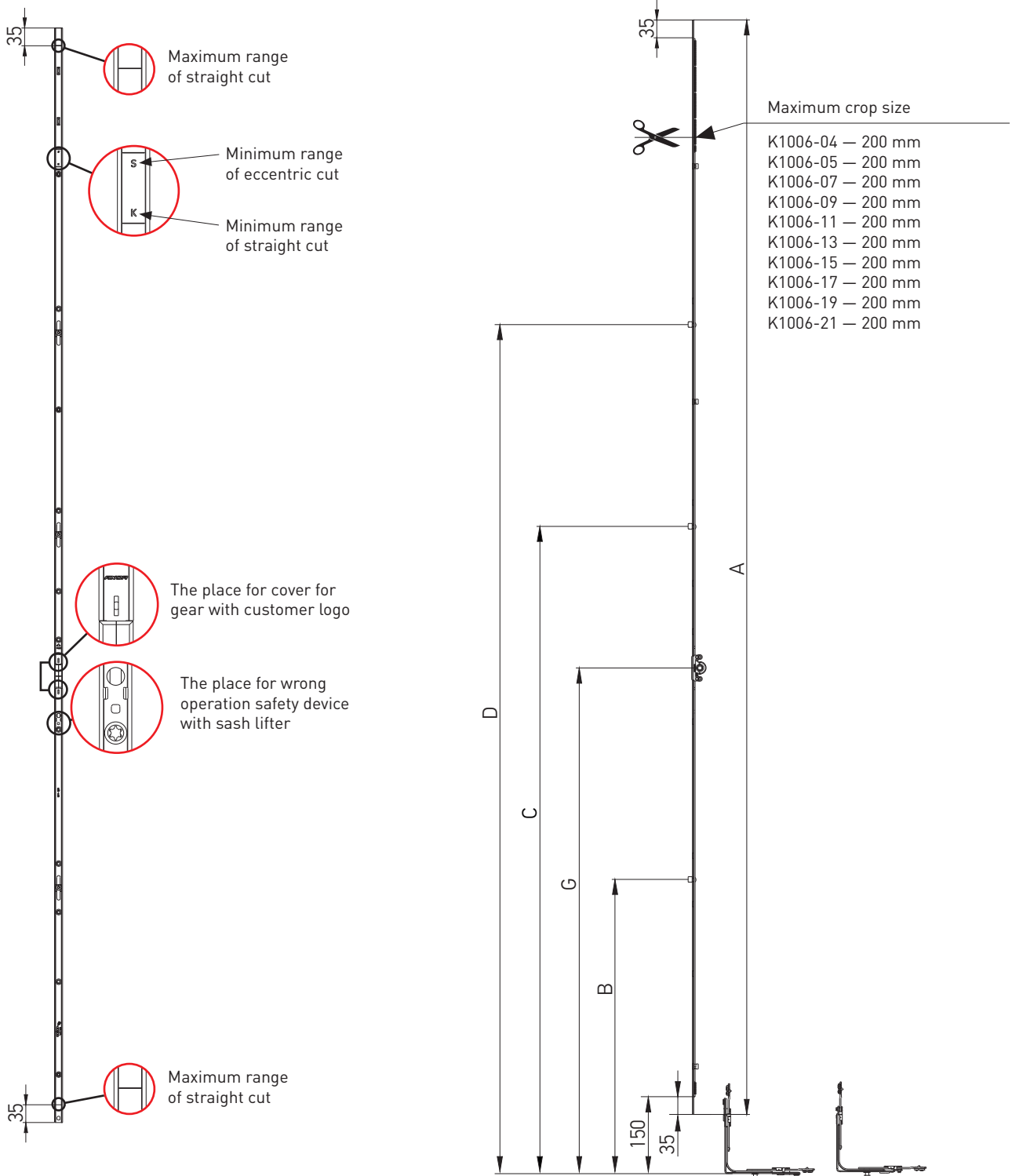



Constant tilt & turn gear

Gears

Description	SRH (mm)	Dimensions								Part No.
		G	A	B	C	D				
Constant gear L=470, G=180, 400-600*	400-600	180	470	—	—	—	—	0	20	K1006-04-N03
Constant gear L=570, G=300, 601-800**	601-800	300	570	—	—	—	—	2	20	K1006-05-N03
Constant gear L=770, G=400, 801-1000, 1 ML	801-1000	400	770	—	480	—	1	3	20	K1006-07-N03
Constant gear L=970, G=500, 1001-1200, 1 ML	1001-1200	500	970	—	680	—	1	5	20	K1006-09-N03
Constant gear L=1170, G=500, 1201-1400, 1 ML	1201-1400	500	1170	—	680	—	1	6	20	K1006-11-N03
Constant gear L=1370, G=500, 1401-1600, 1 ML	1401-1600	500	1370	—	780	—	1	7	20	K1006-13-N03
Constant gear L=1570, G=700, 1601-1800, 2 ML	1601-1800	700	1570	—	780	1280	2	7	20	K1006-15-N03
Constant gear L=1770, G=1000, 1801-2000, 2 ML	1801-2000	1000	1770	780	1280	—	2	10	10	K1006-17-N03
Constant gear L=1970, G=1000, 2001-2200, 2 ML	2001-2200	1000	1970	780	1580	—	2	11	10	K1006-19-N03
Constant gear L=2170, G=1000, 2201-2400, 3 ML	2201-2400	1000	2170	580	1280	1680	3	11	10	K1006-21-N03

* connecting with narrow corner transmission

** there is not a place for the micro lift



**Tilt and turn variable gear
handle position is central**

Gears

Tilt and turn variable gear, handle position is central, backset 7,5 mm.

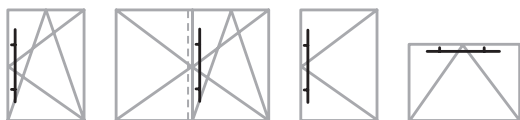
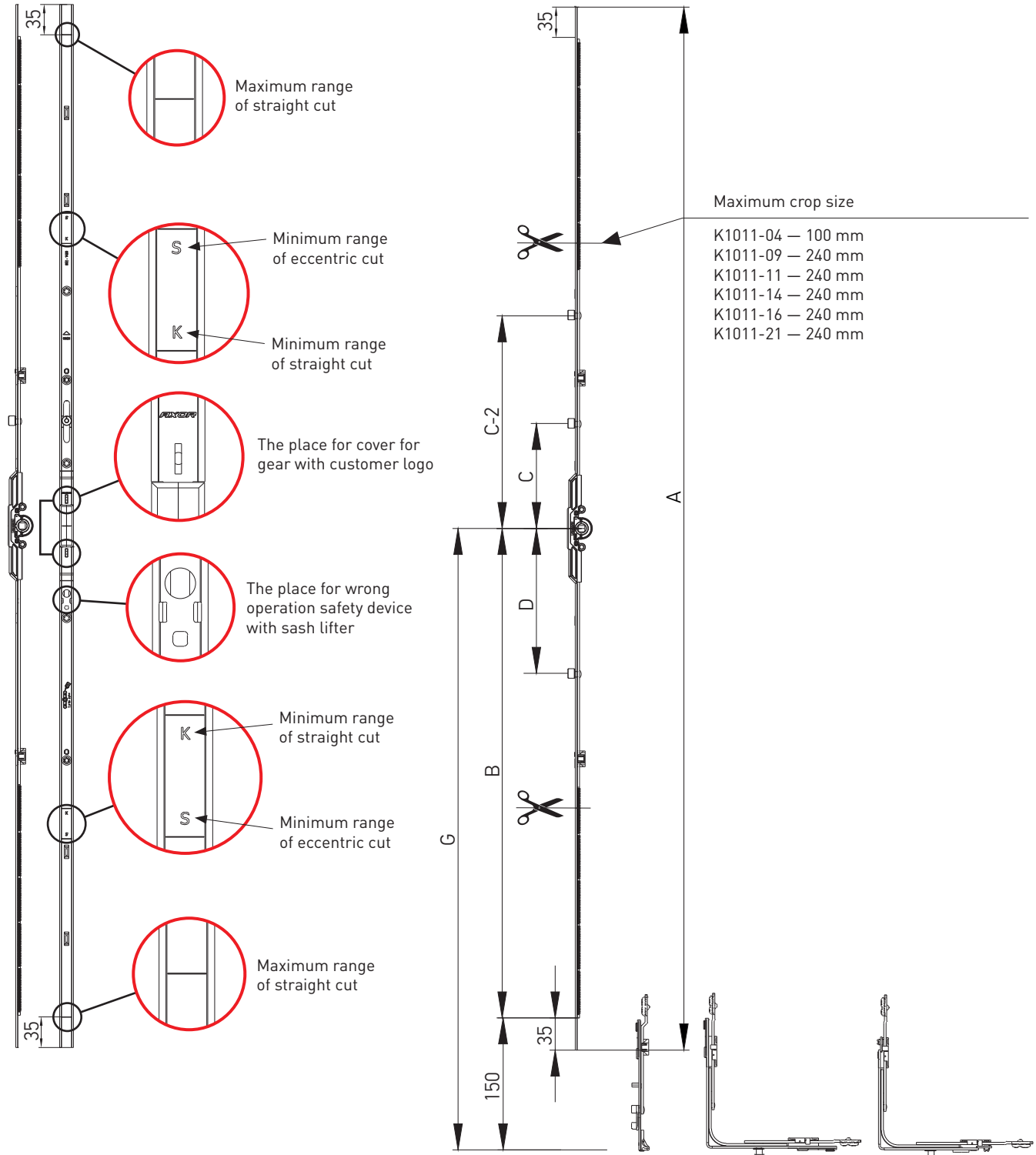

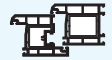

Tilt and turn variable gear handle position is central

Gears

Description	SRH (mm)	Dimensions										Part No.
		G	A	B	C	C-2	D					
Gear variable L= 520, 551-750, backset 7,5 mm* **	551-750	275-375	520	225	—	—	—	—	—	2	20	K1011-04-N03
Gear variable L= 1000, 751-1230, 1 ML, backset 7,5 mm**	751-1230	375-615	1000	465	120	—	—	1	—	4	20	K1011-09-N03
Gear variable L= 1200, 950-1430, 1 ML, backset 7,5 mm	950-1430	475-715	1200	565	120	—	—	1	—	5	20	K1011-11-N03
Gear variable L= 1480, 1231-1710, 2 ML, backset 7,5 mm	1231-1710	615-855	1480	705	120	—	290	2	—	6	10	K1011-14-N03
Gear variable L= 1680, 1431-1910, 2 ML, backset 7,5 mm	1431-1910	715-955	1680	805	265	—	390	2	—	7	10	K1011-16-N03
Gear variable L= 2160, 1911-2390, 3 ML, backset 7,5 mm	1911-2390	955-1195	2160	1045	120	595	490	3	—	11	10	K1011-21-N03
Gear variable L= 1000, 751-1230, 1 MR, backset 7,5 mm**	751-1230	375-615	1000	465	120	—	—	—	1	4	20	K1041-09-N03
Gear variable L= 1200, 950-1430, 1 MR, backset 7,5 mm	950-1430	475-715	1200	565	120	—	—	—	1	5	20	K1041-11-N03
Gear variable L= 1480, 1231-1710, 2 MR, backset 7,5 mm	1231-1710	615-855	1480	705	120	—	290	—	2	6	20	K1041-14-N03
Gear variable L= 1680, 1431-1910, 2 MR, backset 7,5 mm	1431-1910	715-955	1680	805	265	—	390	—	2	7	10	K1041-16-N03
Gear variable L= 2160, 1911-2390, 3 MR, backset 7,5 mm	1911-2390	955-1195	2160	1045	120	595	490	—	3	11	10	K1041-21-N03

* there is not a place for the micro lift;

** not used for double sash windows



**Tilt and turn variable gear
handle position is central**

Gears

Tilt and turn variable gear, handle position is central, backset 25, 30, 35 mm.

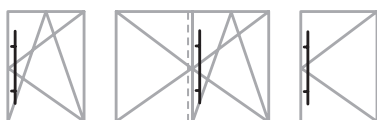
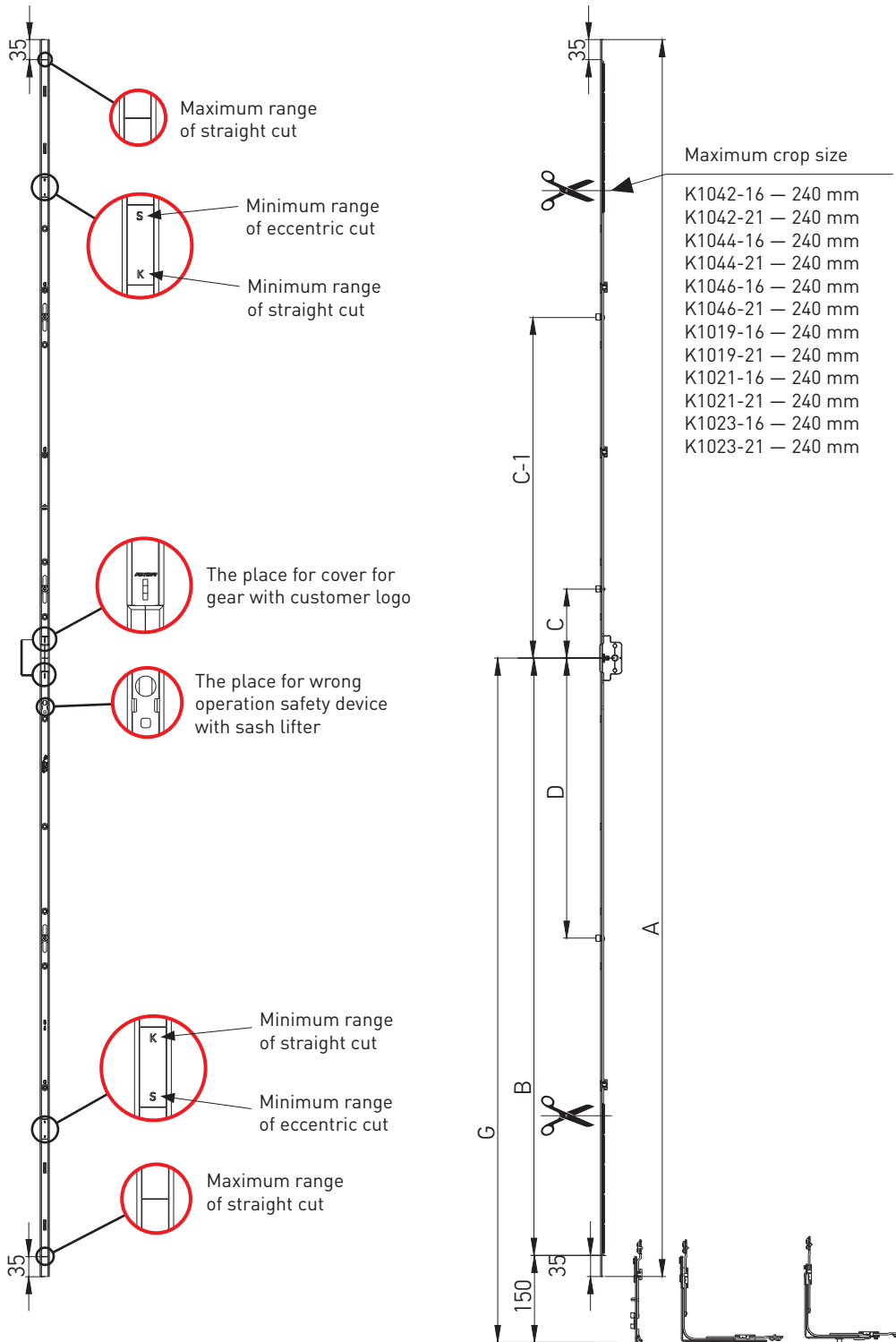



Tilt and turn variable gear handle position is central

Gears

Description	SRH (mm)	Dimensions									Part No.
		A	B	C	C-1	D	G				
Gear variable L= 1680, 1431-1910, backset 25 mm*, 2 ML	1431-1910	1680	805	—	265	390	715-955	2	7	10	K1042-16-N03
Gear variable L= 2160, 1911-2390, backset 25 mm*, 3 ML	1911-2390	2160	1045	120	595	490	955-1195	3	11	10	K1042-21-N03
Gear variable L= 1680, 1431-1910, backset 30 mm*, 2 ML	1431-1910	1680	805	—	265	390	715-955	2	7	10	K1044-16-N03
Gear variable L= 2160, 1911-2390, backset 30 mm*, 3 ML	1911-2390	2160	1045	120	595	490	955-1195	3	11	10	K1044-21-N03
Gear variable L= 1680, 1431-1910, backset 35 mm*, 2 ML	1431-1910	1680	805	—	265	390	715-955	2	7	10	K1046-16-N03
Gear variable L= 2160, 1911-2390, backset 35 mm*, 3 ML	1911-2390	2160	1045	120	595	490	955-1195	3	11	10	K1046-21-N03
Gear variable L= 1680, 1431-1910, backset 25 mm**, 2 ML	1431-1910	1680	805	—	265	390	715-955	2	7	10	K1019-16-N03
Gear variable L= 2160, 1911-2390, backset 25 mm**, 3 ML	1911-2390	2160	1045	120	595	490	955-1195	3	11	10	K1019-21-N03
Gear variable L= 1680, 1431-1910, backset 30 mm**, 2 ML	1431-1910	1680	805	—	265	390	715-955	2	7	10	K1021-16-N03
Gear variable L= 2160, 1911-2390, backset 30 mm**, 3 ML	1911-2390	2160	1045	120	595	490	955-1195	3	11	10	K1021-21-N03
Gear variable L= 1680, 1431-1910, backset 35 mm**, 2 ML	1431-1910	1680	805	—	265	390	715-955	2	7	10	K1023-16-N03
Gear variable L= 2160, 1911-2390, backset 35 mm**, 3 ML	1911-2390	2160	1045	120	595	490	955-1195	3	11	10	K1023-21-N03

* 2-side handle, locking parts with through holes with a diameter of 6.5 mm;

** locking parts with threaded holes M5.

- handle position is central.



Tilt and turn variable gear

Gears

Tilt and turn variable gear, the handle position is constant, backset 7,5 mm.

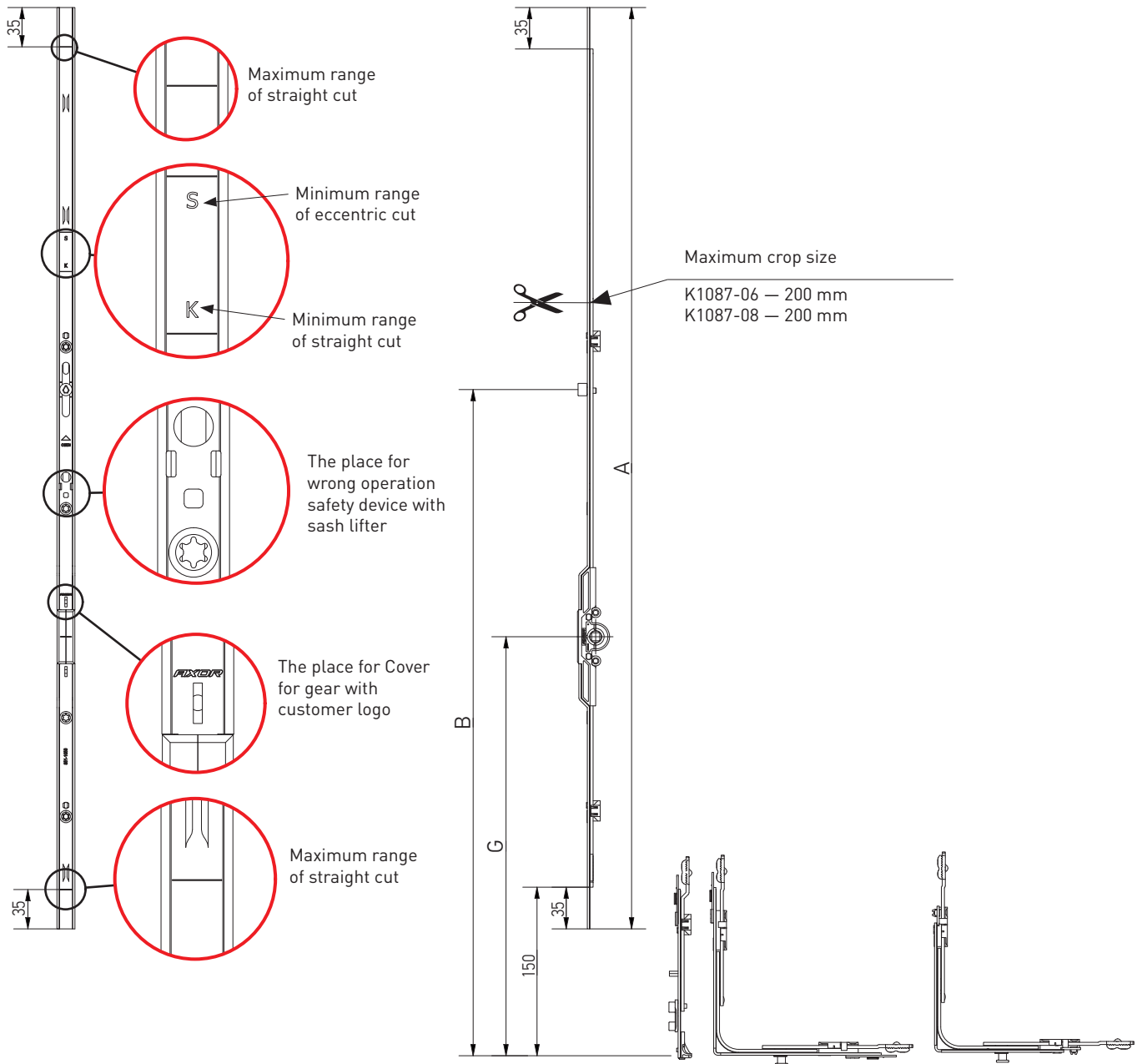



Tilt and turn variable gear

Gears

Description	SRH (mm)	Dimensions						Part No.
		A	B	G				
Gear variable L= 620, 650-850, backset 7,5 mm	650-850	620	805	—	—	3	20	K1087-06-N03
Gear variable L= 820, 851-1050, backset 7,5 mm, 1 ML	851-1050	820	595	375	1	4	20	K1087-08-N03



Tilt and turn variable gear PZ

Gears

Tilt and turn variable gear PZ,
handle position is central, backset 25, 30, 35 mm.

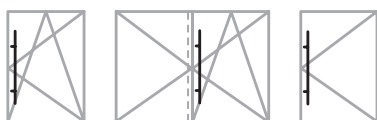
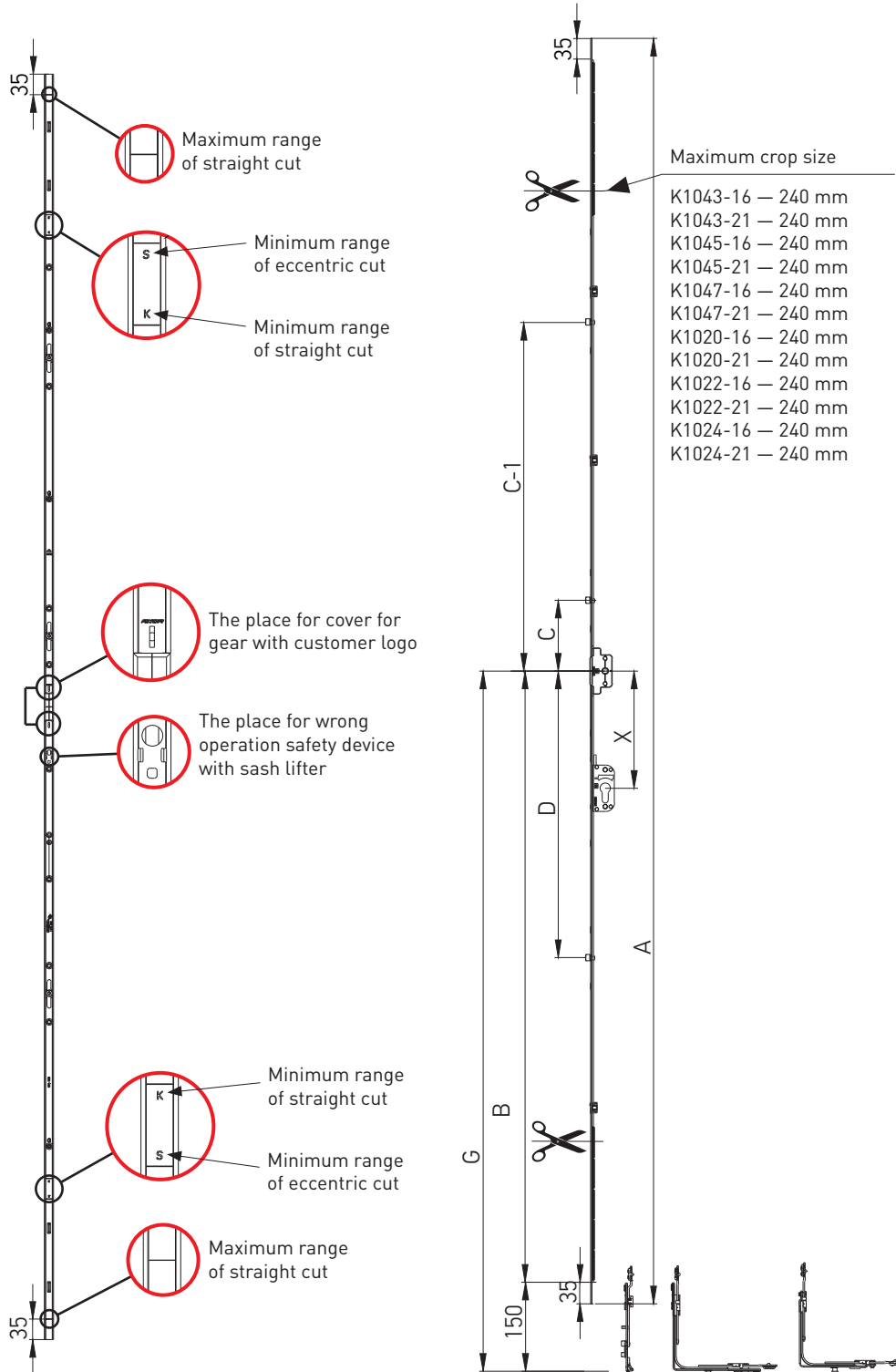



Tilt and turn variable gear PZ

Gears

Description	SRH (mm)	Dimensions										Part No.
		A	B	C	C-1	D	G	X				
Gear variable L= 1680, 1431-1910, backset 25 mm*, 2 ML	1431-1910	1680	805	—	265	390	715-955	200	2	7	10	K1043-16-N03
Gear variable L= 2160, 1911-2390, backset 25 mm*, 3 ML	1911-2390	2160	1045	120	595	490	955-1195	200	3	11	10	K1043-21-N03
Gear variable L= 1680, 1431-1910, backset 30 mm*, 2 ML	1431-1910	1680	805	—	265	390	715-955	200	2	7	10	K1045-16-N03
Gear variable L= 2160, 1911-2390, backset 30 mm*, 3 ML	1911-2390	2160	1045	120	595	490	955-1195	200	3	11	10	K1045-21-N03
Gear variable L= 1680, 1431-1910, backset 35 mm*, 2 ML	1431-1910	1680	805	—	265	390	715-955	200	2	7	10	K1047-16-N03
Gear variable L= 2160, 1911-2390, backset 35 mm*, 3 ML	1911-2390	2160	1045	120	595	490	955-1195	200	3	11	10	K1047-21-N03
Gear variable L= 1680, 1431-1910, backset 25 mm**, 2 ML	1431-1910	1680	805	—	265	390	715-955	200	2	7	10	K1020-16-N03
Gear variable L= 2160, 1911-2390, backset 25 mm**, 3 ML	1911-2390	2160	1045	120	595	490	955-1195	200	3	11	10	K1020-21-N03
Gear variable L= 1680, 1431-1910, backset 30 mm**, 2 ML	1431-1910	1680	805	—	265	390	715-955	200	2	7	10	K1022-16-N03
Gear variable L= 2160, 1911-2390, backset 30 mm**, 3 ML	1911-2390	2160	1045	120	595	490	955-1195	200	3	11	10	K1022-21-N03
Gear variable L= 1680, 1431-1910, backset 35 mm**, 2 ML	1431-1910	1680	805	—	265	390	715-955	200	2	7	10	K1024-16-N03
Gear variable L= 2160, 1911-2390, backset 35 mm**, 3 ML	1911-2390	2160	1045	120	595	490	955-1195	200	3	11	10	K1024-21-N03

* 2-side handle, locking parts with through holes with a diameter of 6.5 mm;
 ** locking parts with threaded holes M5.

- lockable;
- handle position is central.



Turn gear

Turn gear

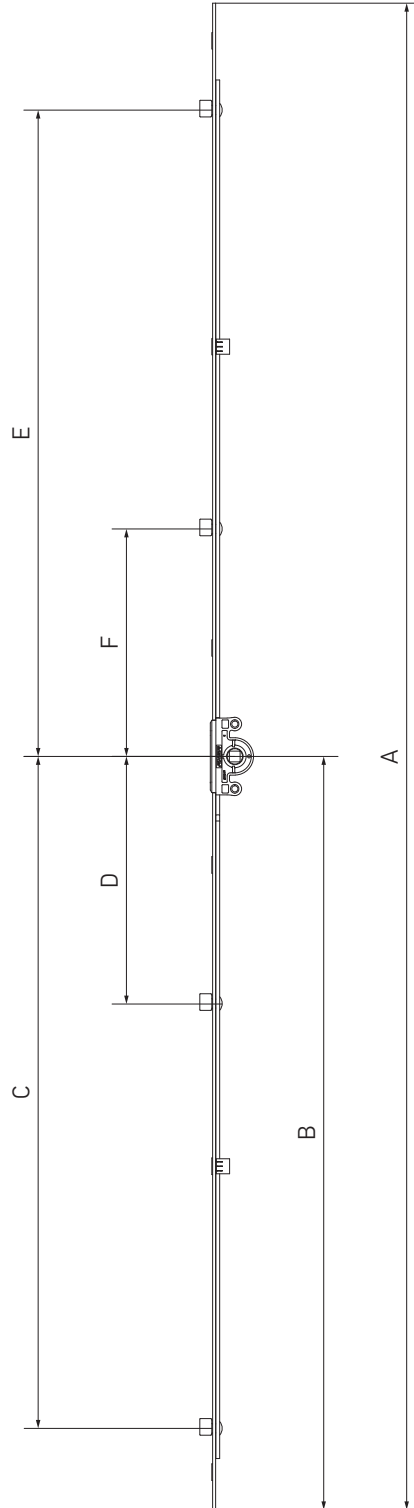



Turn gear

Gears

Description	SRH (mm)	Dimensions										Part No.
		A	B	C	D	E	F					
Turn gear 1 L=300, 300 - 500, 2 ML	300-500	300	150	96	—	79	—	2	—	2	20	K1003-03-N03
Turn gear 2 L=400, 401 - 600, 2 ML	401-600	400	200	146	—	129	—	2	—	2	20	K1003-04-N03
Turn gear 3 L=600, 601 - 800, 2 ML	601-800	600	300	246	—	229	—	2	—	4	20	K1003-06-N03
Turn gear 4 L=800, 801 - 1000, 2 ML	801-1000	800	400	346	—	329	—	2	—	4	20	K1003-08-N03
Turn gear 5 L=1000, 1001 - 1200, 3 ML	1001-1200	1000	500	446	—	429	101	3	—	8	20	K1003-10-N03
Turn gear 6 L=1200, 1201 - 1400, 3 ML	1201-1400	1200	600	546	—	530	101	3	—	8	20	K1003-12-N03
Turn gear 7 L=1400, 1401 - 1600, 3 ML	1401-1600	1400	700	646	—	629	101	3	—	8	20	K1003-14-N03
Turn gear 8 L=1600, 1601 - 1800, 4 ML	1601-1800	1600	800	746	318	729	301	4	—	8	10	K1003-16-N03
Turn gear 9 L=1800, 1801 - 2000, 4 ML	1801-2000	1800	900	846	318	829	301	4	—	10	10	K1003-18-N03
Turn gear 10 L=2000, 2001 - 2200, 4 ML	2001-2200	2000	1000	946	318	929	301	4	—	10	10	K1003-20-N03
Turn gear 11 L=2200, 2201 - 2400, 4 ML	2201-2400	2200	1100	1046	318	1029	301	4	—	11	10	K1003-22-N03
Turn gear 1 L=300, 300 - 500, 2 MR	300-500	300	150	96	—	79	—	—	2	2	20	K1033-03-N03
Turn gear 2 L=400, 401 - 600, 2 MR	401-600	400	200	146	—	129	—	—	2	2	20	K1033-04-N03
Turn gear 3 L=600, 601 - 800, 2 MR	601-800	600	300	246	—	229	—	—	2	4	20	K1033-06-N03
Turn gear 4 L=800, 801 - 1000, 2 MR	801-1000	800	400	346	—	329	—	—	2	4	20	K1033-08-N03
Turn gear 5 L=1000, 1001 - 1200, 3 MR	1001-1200	1000	500	446	—	429	101	—	3	8	20	K1033-10-N03
Turn gear 6 L=1200, 1201 - 1400, 3MR	1201-1400	1200	600	546	—	530	101	—	3	8	20	K1033-12-N03
Turn gear 7 L=1400, 1401 - 1600, 3MR	1401-1600	1400	700	646	—	629	101	—	3	8	20	K1033-14-N03
Turn gear 8 L=1600, 1601 - 1800, 4MR	1601-1800	1600	800	746	318	729	301	—	4	8	10	K1033-16-N03
Turn gear 9 L=1800, 1801 - 2000, 4MR	1801-2000	1800	900	846	318	829	301	—	4	10	10	K1033-18-N03
Turn gear 10 L=2000, 2001 - 2200, 4MR	2001-2200	2000	1000	946	318	929	301	—	4	10	10	K1033-20-N03
Turn gear 11 L=2200, 2201 - 2400, 4MR	2201-2400	2200	1100	1046	318	1029	301	—	4	11	10	K1033-22-N03



Turn gear

Gears

Turn gear, backset 7,5 mm.

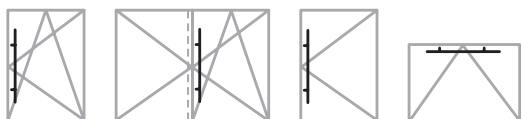
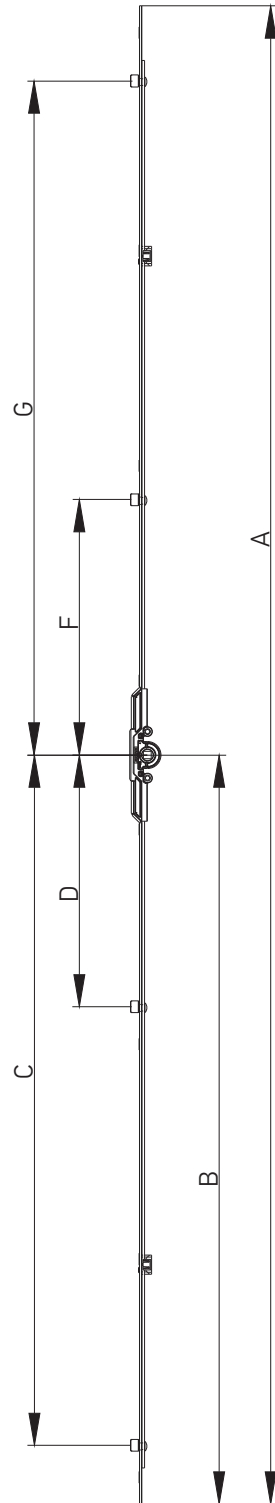
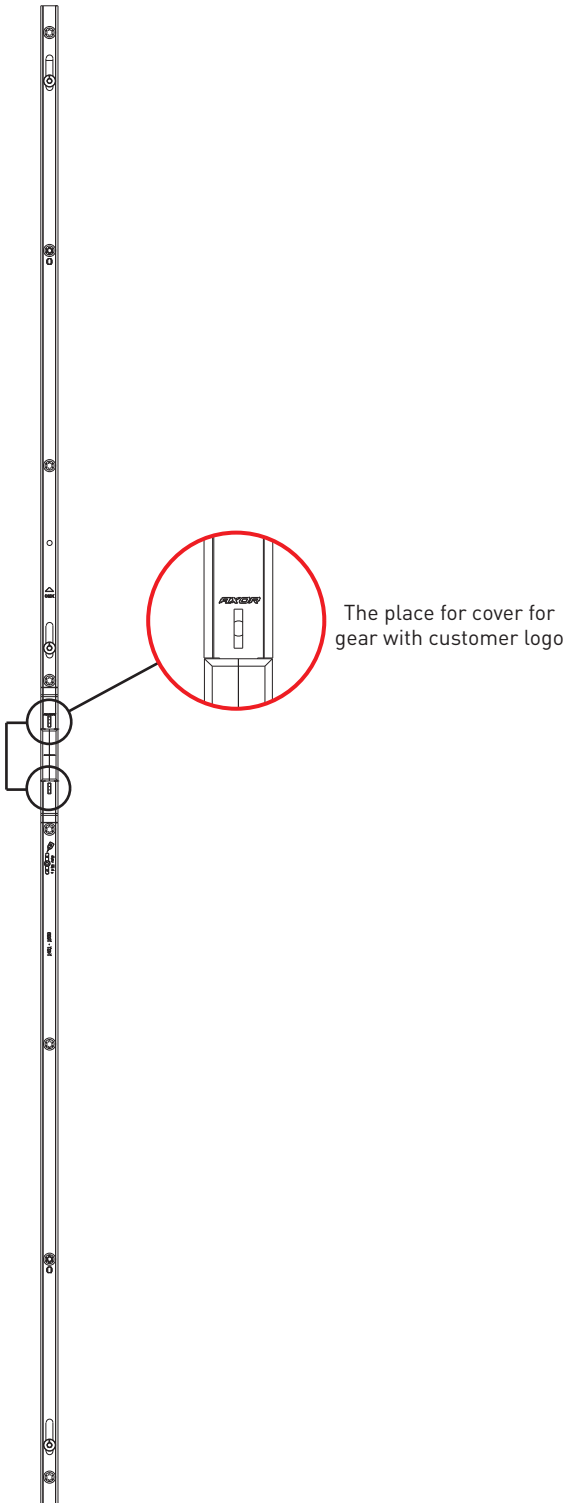



Turn gear

Gears

Description	SRH (mm)	Dimensions									Part No.
		A	B	C	D	F	G				
Turn gear 2, L=400, 401-600, backset 7,5 mm, 2 ML	400-600	394	197	—	143	—	126	2	4	20	K1049-04-N03
Turn gear 3, L=600, 601-800, backset 7,5 mm, 2 ML	601-800	594	297	—	243	—	226	2	4	20	K1049-06-N03
Turn gear 4, L=800, 801-1000, backset 7,5 mm, 2 ML	800-1000	794	397	—	343	—	326	2	6	20	K1049-08-N03
Turn gear 5, L=1000, 1001-1200, backset 7,5 mm, 3 ML	1001-1200	994	497	—	443	98	426	3	6	20	K1049-10-N03
Turn gear 6, L=1200, 1201-1400, backset 7,5 mm, 3 ML	1201-1400	1194	597	—	543	98	526	3	8	20	K1049-12-N03
Turn gear 7, L=1400, 1401-1600, backset 7,5 mm, 3 ML	1401-1600	1394	697	—	643	98	626	3	8	20	K1049-14-N03
Turn gear 8, L=1600, 1601-1800, backset 7,5 mm, 4 ML	1601-1800	1594	797	743	315	298	726	4	10	10	K1049-16-N03
Turn gear 9, L=1800, 1801-2000, backset 7,5 mm, 4 ML	1801-2000	1794	897	843	315	298	826	4	10	10	K1049-18-N03
Turn gear 10, L=2000, 2001-2200, backset 7,5 mm, 4 ML	2001-2200	1994	997	943	315	298	926	4	12	10	K1049-20-N03
Turn gear 11, L=2200, 2201-2400, backset 7,5 mm, 4 ML	2201-2400	2194	1097	1043	315	298	1026	4	12	10	K1049-22-N03



Double-sash gear with integrated locking plates

Gears

Double-sash gear with integrated locking plates (used with tilt & turn variable gear with central handle position, Part No. K1001...)

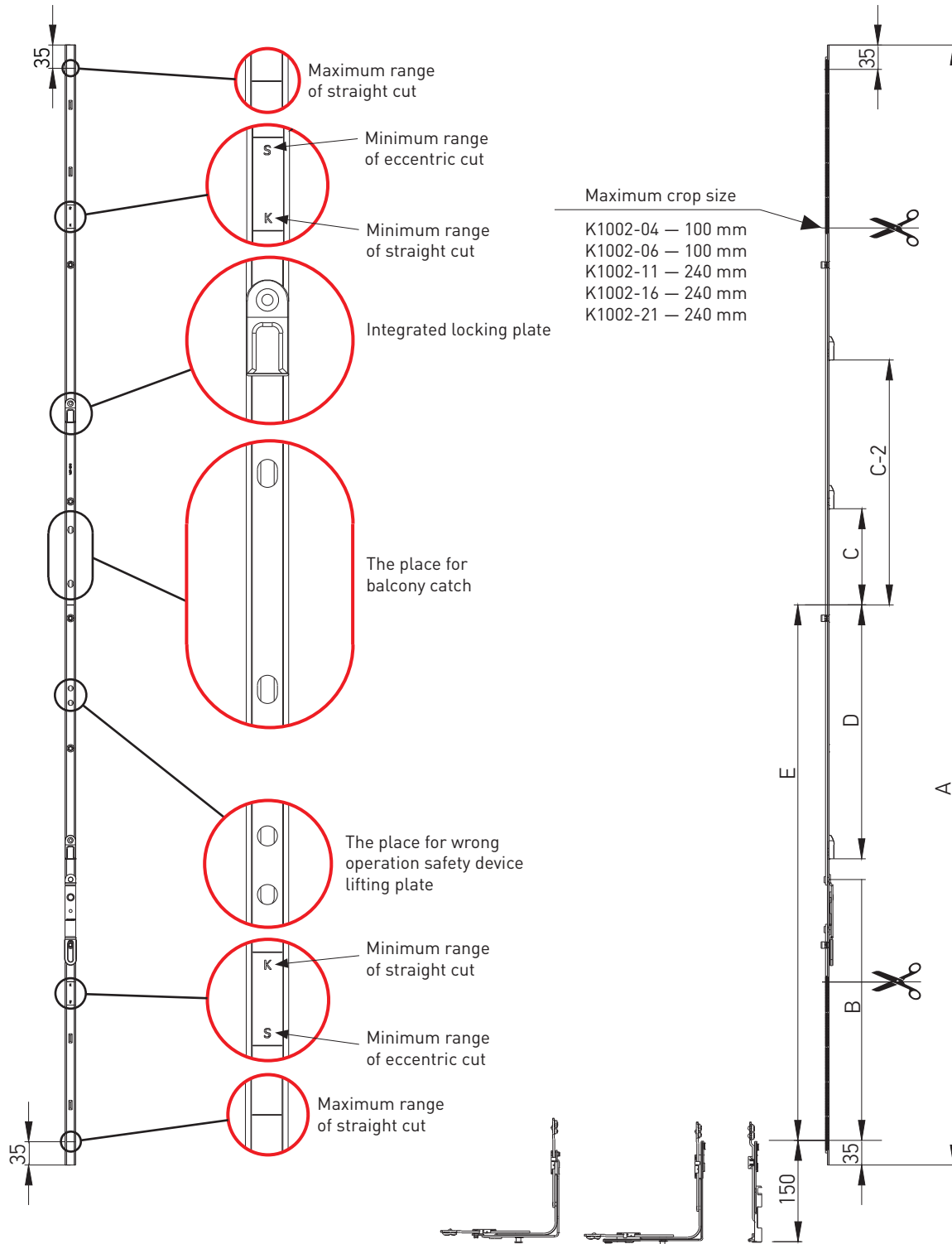

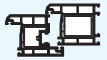

Double-sash gear with integrated locking plates

Gears

Description	SRH (mm)	Dimensions									Part No.
		A	B	C	D	C-2	E				
Double-sash gear 1*** L=520, 551-750	551-750	520	265	—	—	—	225	0	3	20	K1002-04-N03
Double-sash gear 2** L=720, 751-950	751-950	720	393	129,5	—	—	325	1	4	20	K1002-06-N03
Double-sash gear 3 L=1200, 951-1430	951-1430	1200	393	129,5	—	—	565	1	6	20	K1002-11-N03
Double-sash gear 3A, L=1200, 951-1430	951-1430	1200	643	129,5	216,5	—	565	2	6	20	K1002-12-N03
Double-sash gear L=1480, 1231-1710	1231-1710	1480	383	128,5	280,5	—	705	2	8	20	K1002-14-N03
Double-sash gear 4*** L=1680, 1431-1910	1431-1910	1680	393	274,5	380,5	—	805	2	8	10	K1002-16-N03
Double-sash gear 5*** L=2160, 1911-2390	1911-2390	2160	393	129,5	480,5	604,5	1045	3	11	10	K1002-21-N03

- for double-sash profile with opposite hardware groove;
- gear with opposite motion;
- locking plates were installed.

* there is not a place for the micro lift

** not used with 7.5 mm backset

*** there is a place for balcony catch available

PERFORM THE CUT IN THE OPEN POSITION OF THE HANDLE!



Constant double-sash gear

Gears

Constant double-sash gear
(used with constant tilt & turn gear, Part No. K1004...)

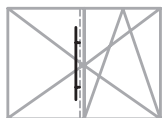
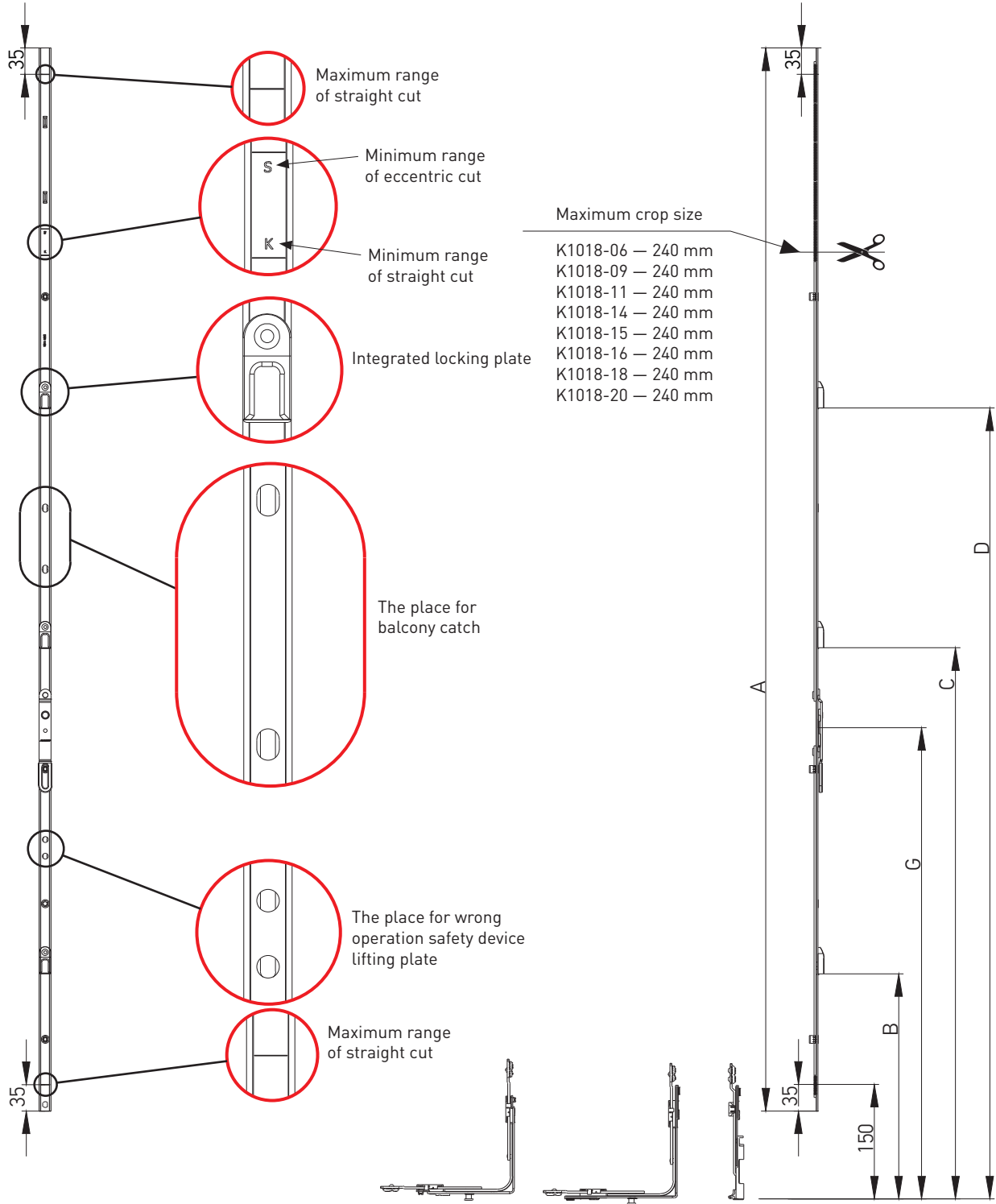



Constant double-sash gear

Gears

Description	SRH (mm)	Dimensions								Part No.
		G	A	B	C	D				
Constant double-sash gear G=300, L=690 mm*	681-920	300	690	—	439,5	—	1	4	20	K1018-06-N03
Constant double-sash gear G=450, L=930 mm	921-1160	450	930	—	579,5	—	1	7	20	K1018-09-N03
Constant double-sash gear G=600, L=1170 mm	1161-1400	600	1170	—	729,5	—	1	8	20	K1018-11-N03
Constant double-sash gear G=600, L=1410 mm	1401-1640	600	1410	—	729,5	1047,5	2	10	20	K1018-14-N03
Constant double-sash gear G=600, L=1650 mm	1641-1880	600	1650	—	729,5	1252,5	2	10	10	K1018-15-N03
Constant double-sash gear G=1000, L=1650 mm**	1641-1880	1000	1650	729,5	1272,5	—	2	10	10	K1018-16-N03
Constant double-sash gear G=1000, L=1890 mm**	1881-2120	1000	1890	729,5	1396,5	—	2	11	10	K1018-18-N03
Constant double-sash gear G=1000, L=2130 mm**	2121-2360	1000	2130	729,5	1129,5	1732,5	3	13	10	K1018-20-N03

- for double-sash profile with opposite hardware groove;
- gear with opposite motion;
- locking plates were installed.

* there is not a place for the micro lift

** there is a place for balcony catch available

PERFORM THE CUT IN THE OPEN POSITION OF THE HANDLE!



Constant double-sash gear

Gears

Constant double-sash gear
(used with constant tilt & turn gear, Part No. K1006...)

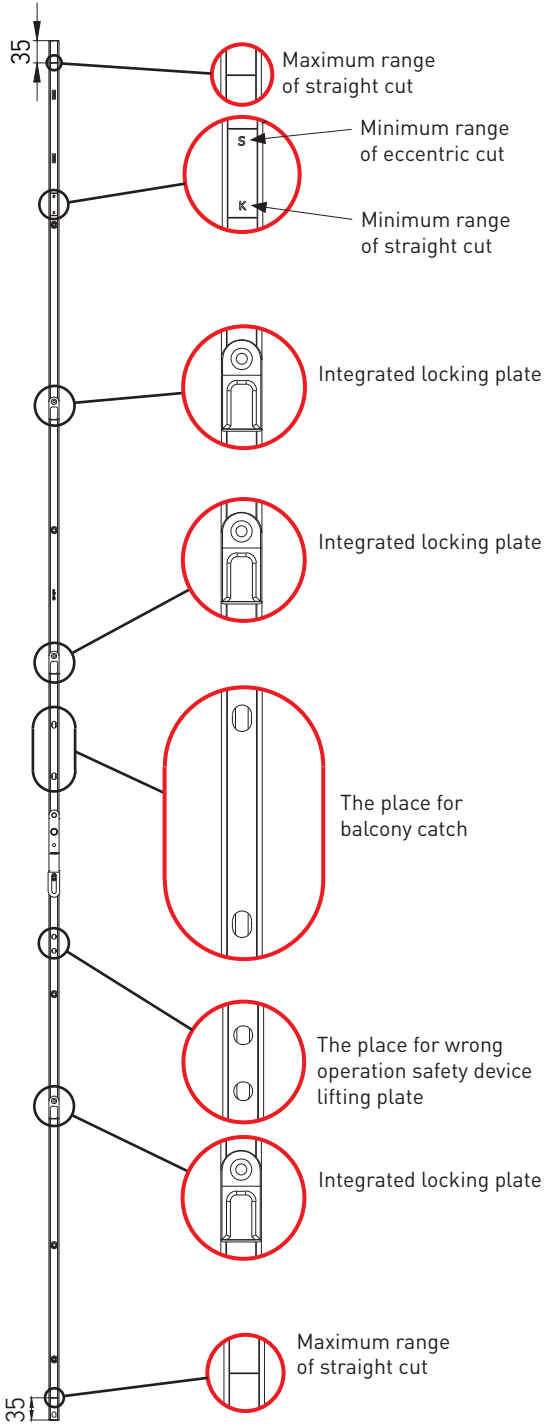

Maximum crop size

- K1018-06 — 240 mm
- K1007-05 — 200 mm
- K1007-07 — 200 mm
- K1007-09 — 200 mm
- K1007-11 — 200 mm
- K1007-13 — 200 mm
- K1007-15 — 200 mm
- K1007-17 — 200 mm
- K1007-19 — 200 mm
- K1007-21 — 200 mm

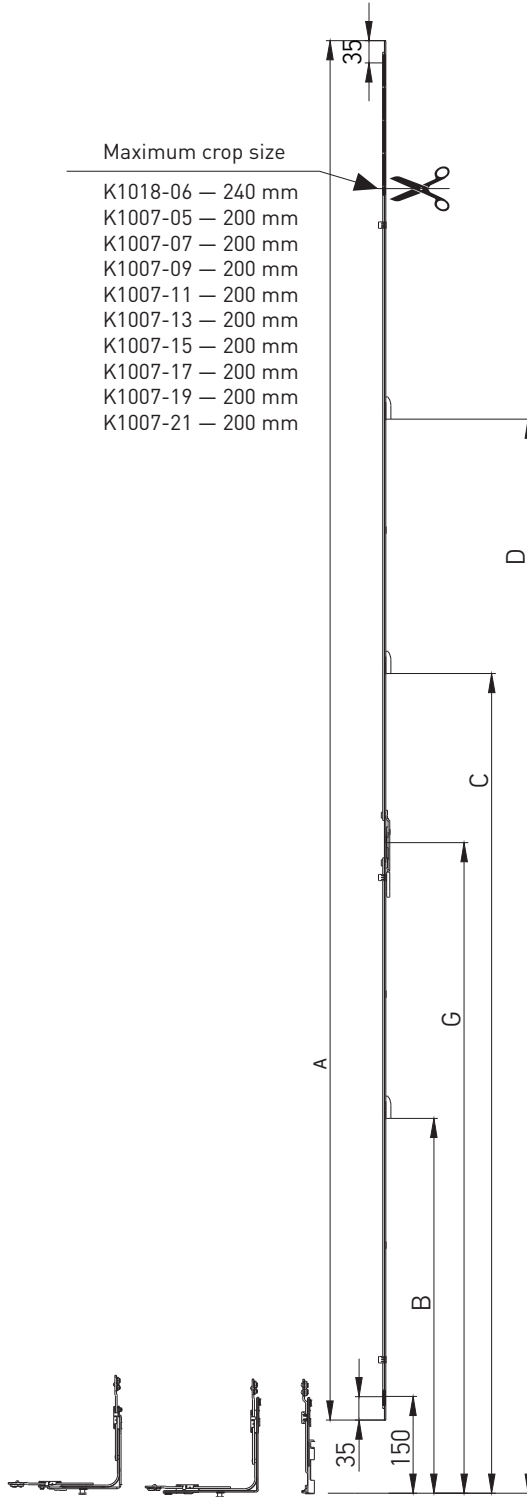

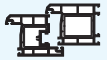

Constant double-sash gear

Gears

Description	SRH (mm)	Dimensions								Part No.
		G	A	B	C	D				
Constant double-sash gear L=570, G=300, 600-800*	600-800	300	570	—	—	—	—	3	20	K1007-05-N03
Constant double-sash gear L=770, G=360, 801-1000	801-1000	360	770	—	489,5	—	1	5	20	K1007-07-N03
Constant double-sash gear L=970, G=500, 1001-1200	1001-1200	500	970	—	689,5	—	1	5	20	K1007-09-N03
Constant double-sash gear L=1170, G=500, 1201-1400	1201-1400	500	1170	—	689,5	—	1	6	20	K1007-11-N03
Constant double-sash gear L=1370, G=500, 1401-1600	1401-1600	500	1370	—	789,5	—	1	7	10	K1007-13-N03
Constant double-sash gear L=1570, G=400, 1601-1800	1601-1800	400	1570	—	789,5	1289,5	2	9	10	K1007-15-N03
Constant double-sash gear L=1770, G=1000, 1801-2000**	1801-2000	1000	1770	789,5	1289,5	—	2	8	10	K1007-17-N03
Constant double-sash gear L=1970, G=1000, 2001-2200**	2001-2200	1000	1970	789,5	1589,5	—	2	9	10	K1007-19-N03
Constant double-sash gear L=2170, G=1000, 2201-2400**	2201-2400	1000	2170	589,5	1289,5	1689,5	3	10	10	K1007-21-N03

- for double-sash profile with opposite hardware groove;
- Gear with opposite motion;
- locking plates were installed.

* there is not a place for the micro lift

** there is a place for balcony catch available

PERFORM THE CUT IN THE OPEN POSITION OF THE HANDLE!



Constant double-sash gear

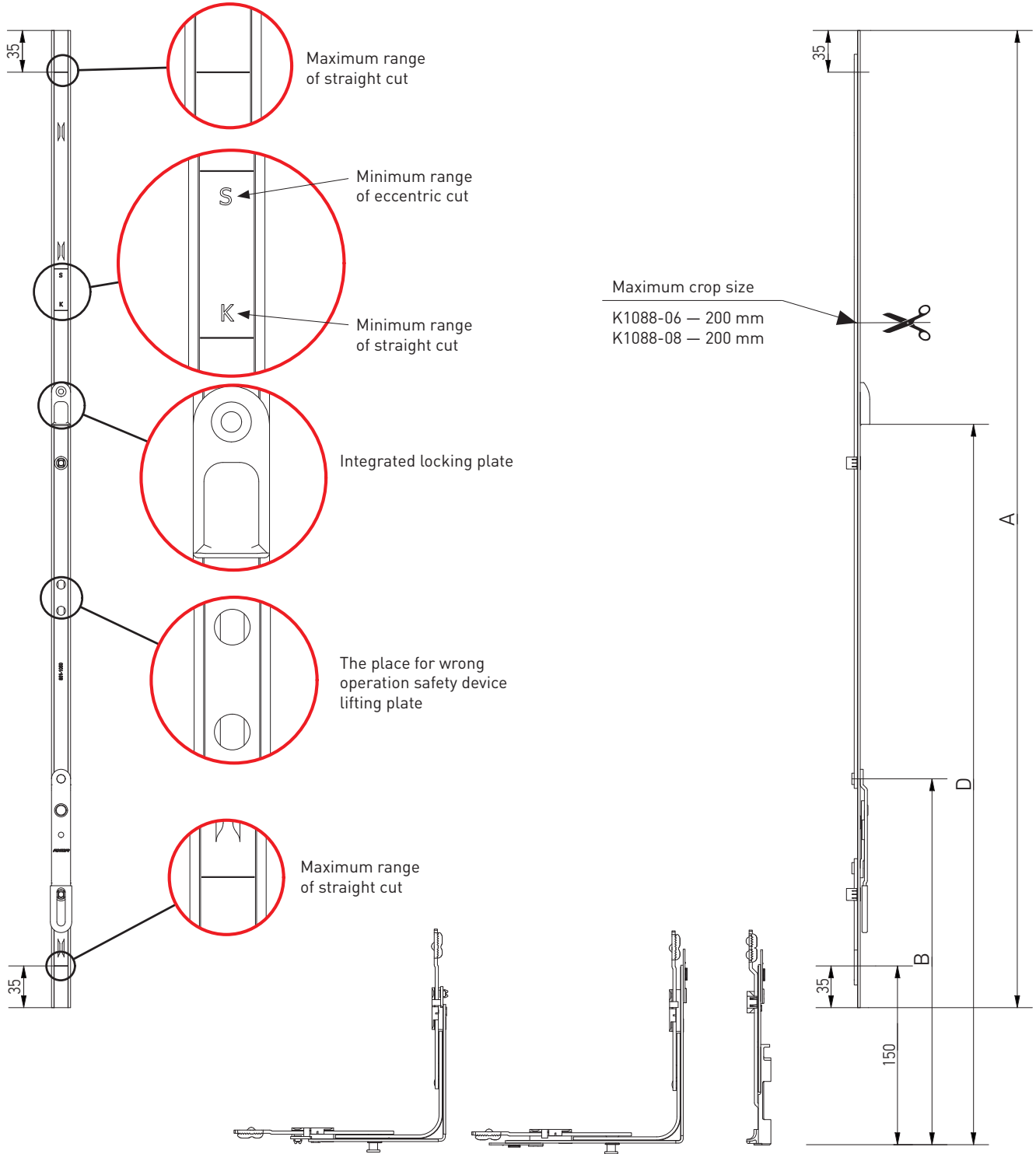

Gears

Constant double-sash gear
(used with constant tilt & turn gear, Part No. K1087...)



Constant double-sash gear

Gears

Description	SRH (mm)	Dimensions						Part No.
		A	B	G				
Constant double-sash gear L= 620, 650-850	650-850	620	307	—	—	4	20	K1088-06-N03
Constant double-sash gear L= 820, 851-1050, 1 ML	851-1050	820	307	604,5	1	6	20	K1088-08-N03



Gear for sliding system, backset 15 mm

Gears

Gear for sliding system, backset 15 mm

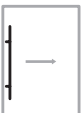
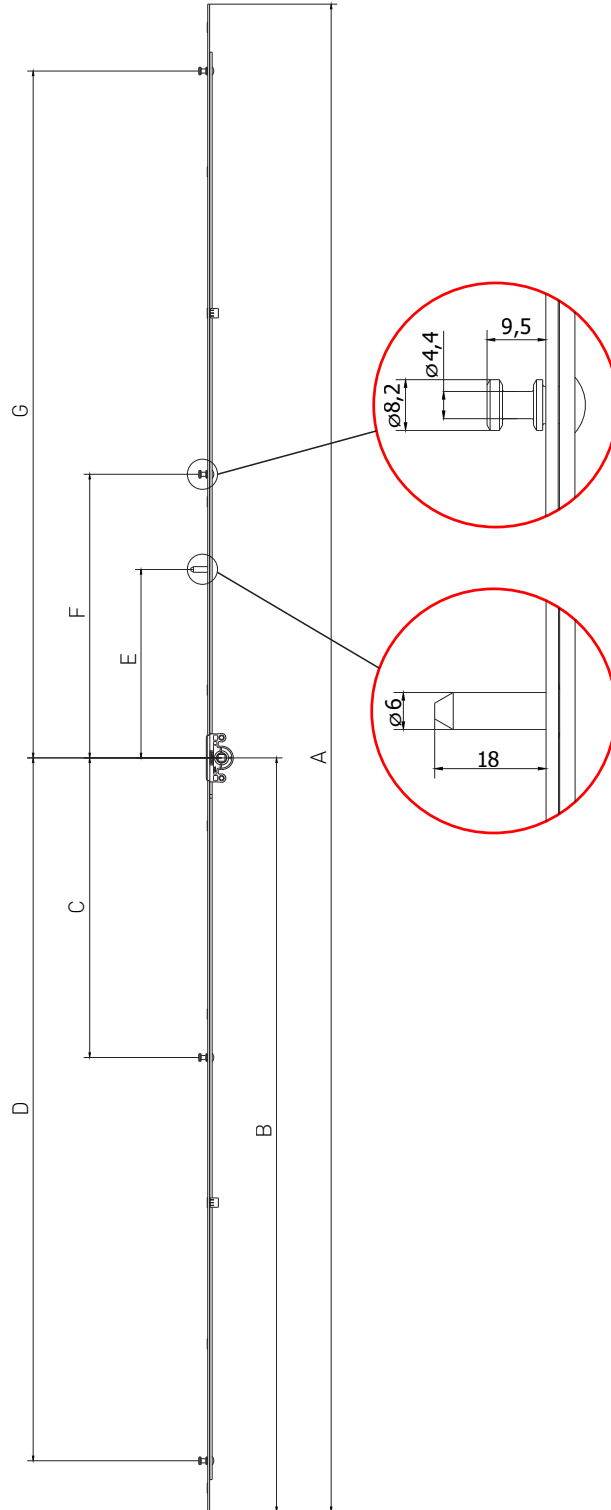



Gear for sliding system, backset 15 mm

Gears

Description	SRH (mm)	Dimensions									Part No.
		A	B	C	D	E	F	G			
Gear for sliding system 1, L=300, 300-400, 2 MR	300-400	300	150	—	96	49	—	79	2	3	K1005-03-N03
Gear for sliding system 2, L=400, 401-600, 2 MR	401-600	400	200	—	146	99	—	129	2	4	K1005-04-N03
Gear for sliding system 3, L=600, 601-800, 2 MR	601-800	600	300	—	246	152	—	229	2	4	K1005-06-N03
Gear for sliding system 4, L=800, 801-1000, 2 MR	800-1000	800	400	—	346	152	—	329	2	6	K1005-08-N03
Gear for sliding system 5, L=1000, 1001-1200, 3 MR	1001-1200	1000	500	—	446	200	101	429	3	6	K1005-10-N03
Gear for sliding system 6, L=1200, 1201-1400, 3 MR	1201-1400	1200	600	—	546	200	101	529	3	8	K1005-12-N03
Gear for sliding system 7, L=1400, 1401-1600, 3 MR	1401-1600	1400	700	—	646	200	101	629	3	8	K1005-14-N03
Gear for sliding system 8, L=1600, 1601-1800, 4 MR	1601-1800	1600	800	318	746	200	301	729	4	10	K1005-16-N03
Gear for sliding system 9, L=1800, 1801-2000, 4 MR	1801-2000	1800	900	318	846	200	301	829	4	10	K1005-18-N03
Gear for sliding system 10, L=2000, 2001-2200, 4 MR	2001-2200	2000	1000	318	946	200	301	929	4	12	K1005-20-N03
Gear for sliding system 11, L=2200, 2201-2400, 4 MR	2201-2400	2200	1100	318	1046	200	301	1029	4	12	K1005-22-N03



**Gear for sliding system,
backset 7,5 mm**

Gears

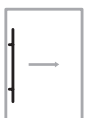
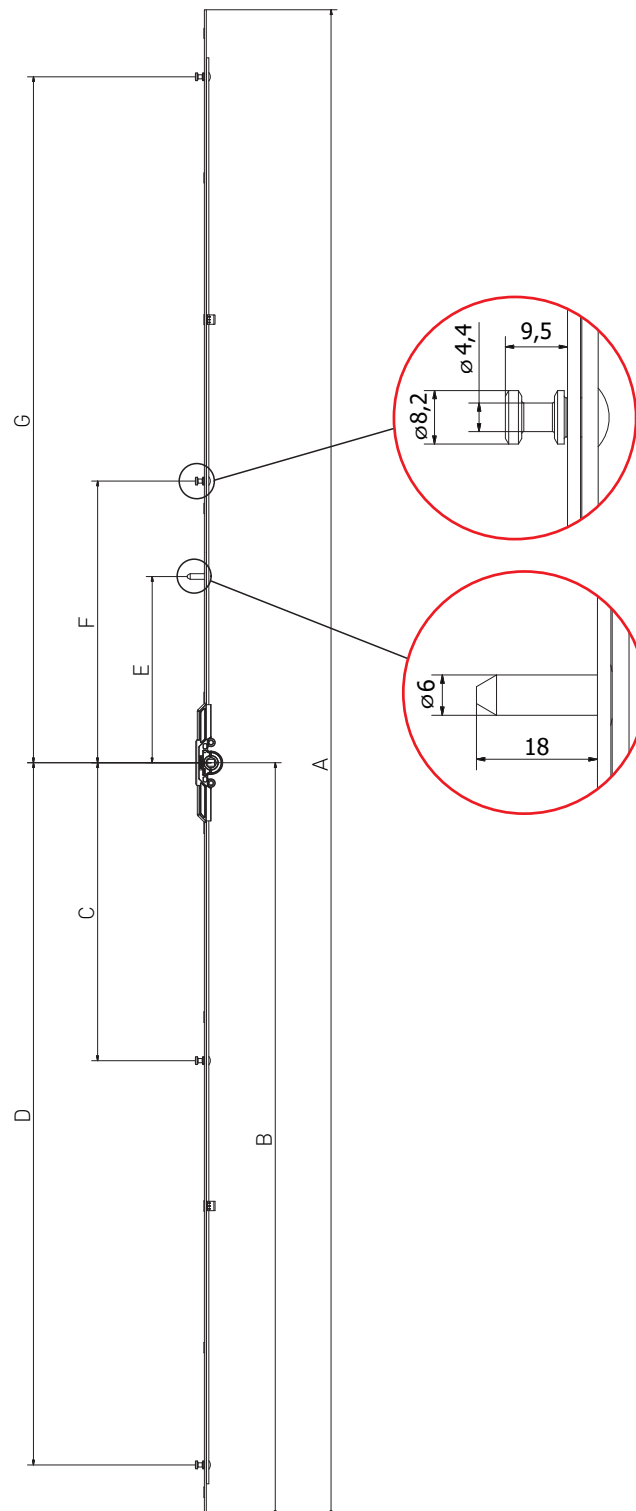
Gear for sliding system, backset 7,5 mm



**Gear for sliding system,
backset 7,5 mm**
Gears

Description	SRH (mm)	Dimensions									Part No.
		A	B	C	D	E	F	G			
Gear for sliding system 2, L=400, 401-600, backset 7,5 mm, 2 MR	401-600	394	197	—	143	96	—	126	2	4	K1048-04-N03
Gear for sliding system 3, L=600, 601-800, backset 7,5 mm, 2 MR	601-800	594	297	—	243	149	—	226	2	4	K1048-06-N03
Gear for sliding system 4, L=800, 801-1000, backset 7,5 mm, 2 MR	800-1000	794	397	—	343	149	—	326	2	6	K1048-08-N03
Gear for sliding system 5, L=1000, 1001-1200, backset 7,5 mm, 3 MR	1001-1200	994	497	—	443	197	98	426	3	6	K1048-10-N03
Gear for sliding system 6, L=1200, 1201-1400, backset 7,5 mm, 3 MR	1201-1400	1194	597	—	543	197	98	526	3	8	K1048-12-N03
Gear for sliding system 7, L=1400, 1401-1600, backset 7,5 mm, 3 MR	1401-1600	1394	697	—	643	197	98	626	3	8	K1048-14-N03
Gear for sliding system 8, L=1600, 1601-1800, backset 7,5 mm, 4 MR	1601-1800	1594	797	315	743	197	298	726	4	10	K1048-16-N03
Gear for sliding system 9, L=1800, 1801-2000, backset 7,5 mm, 4 MR	1801-2000	1794	897	315	843	197	298	826	4	10	K1048-18-N03
Gear for sliding system 10, L=2000, 2001-2200, backset 7,5 mm, 4 MR	2001-2200	1994	997	315	943	197	298	926	4	12	K1048-20-N03
Gear for sliding system 11, L=2200, 2201-2400, backset 7,5 mm, 4 MR	2201-2400	2194	1097	315	1043	197	298	1026	4	12	K1048-22-N03



**Gear for sliding system
lockable**

Gears

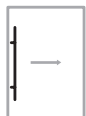
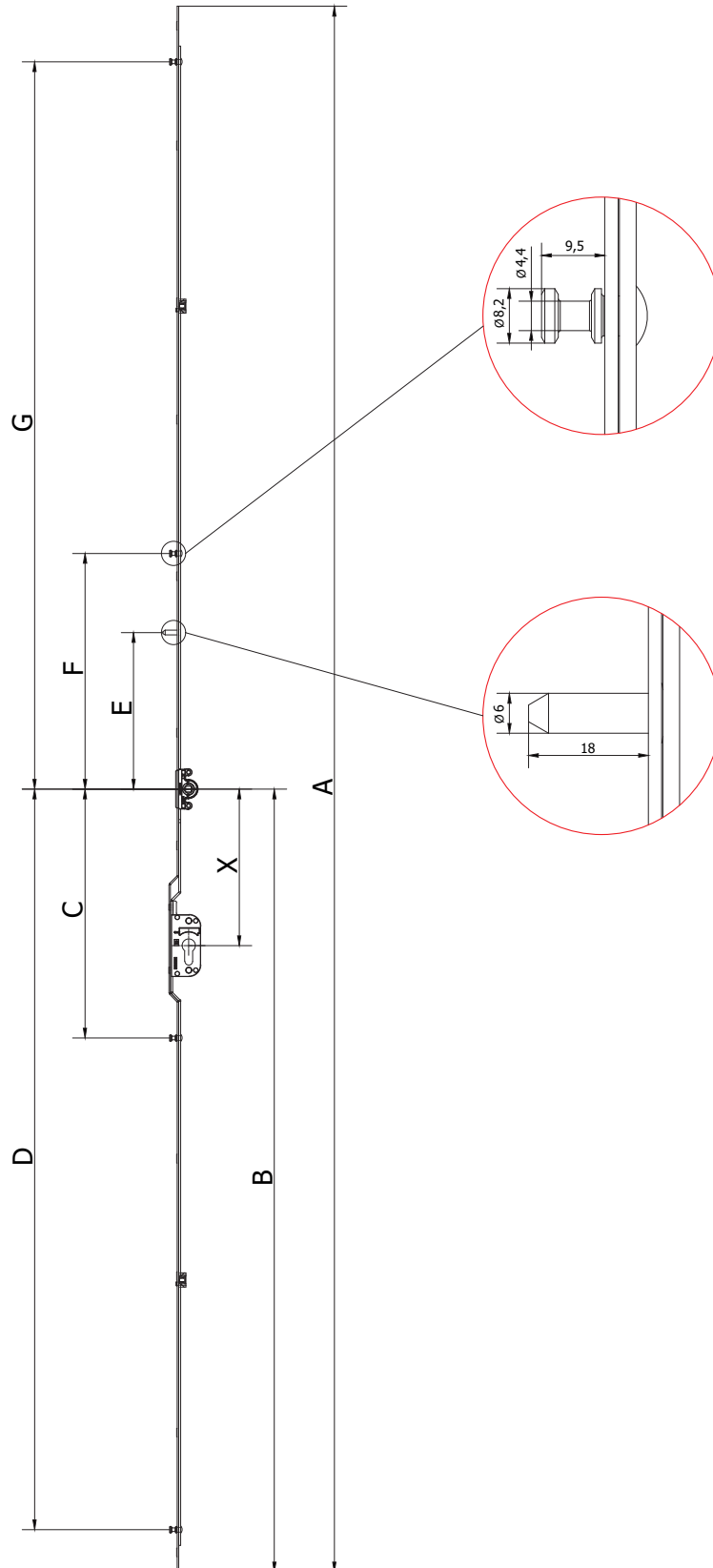

Gear for sliding system lockable, backset 15 mm.





**Gear for sliding system
lockable**

Gears

Description	SRH (mm)	Dimensions											Part No.
		A	B	C	D	E	F	G	X				
Gear for sliding system L=1600, 1601-1800, 4 MR	1601-1800	1600	800	318	746	200	301	729	200	4	9	10	K1074-16-N03
Gear for sliding system L=1800, 1801-2000, 4 MR	1801-2000	1800	900	318	846	200	301	829	200	4	9	10	K1074-18-N03
Gear for sliding system L=2000, 2001-2200, 4 MR	2001-2200	2000	1000	318	946	200	301	929	200	4	11	10	K1074-20-N03
Gear for sliding system L=2200, 2201-2400, 4 MR	2201-2400	2200	1100	318	1046	200	301	1029	200	4	11	10	K1074-22-N03



Tilt and turn variable gear handle position is central FLAX pin

Gears

Tilt and turn variable gear handle position is central FLAX pin

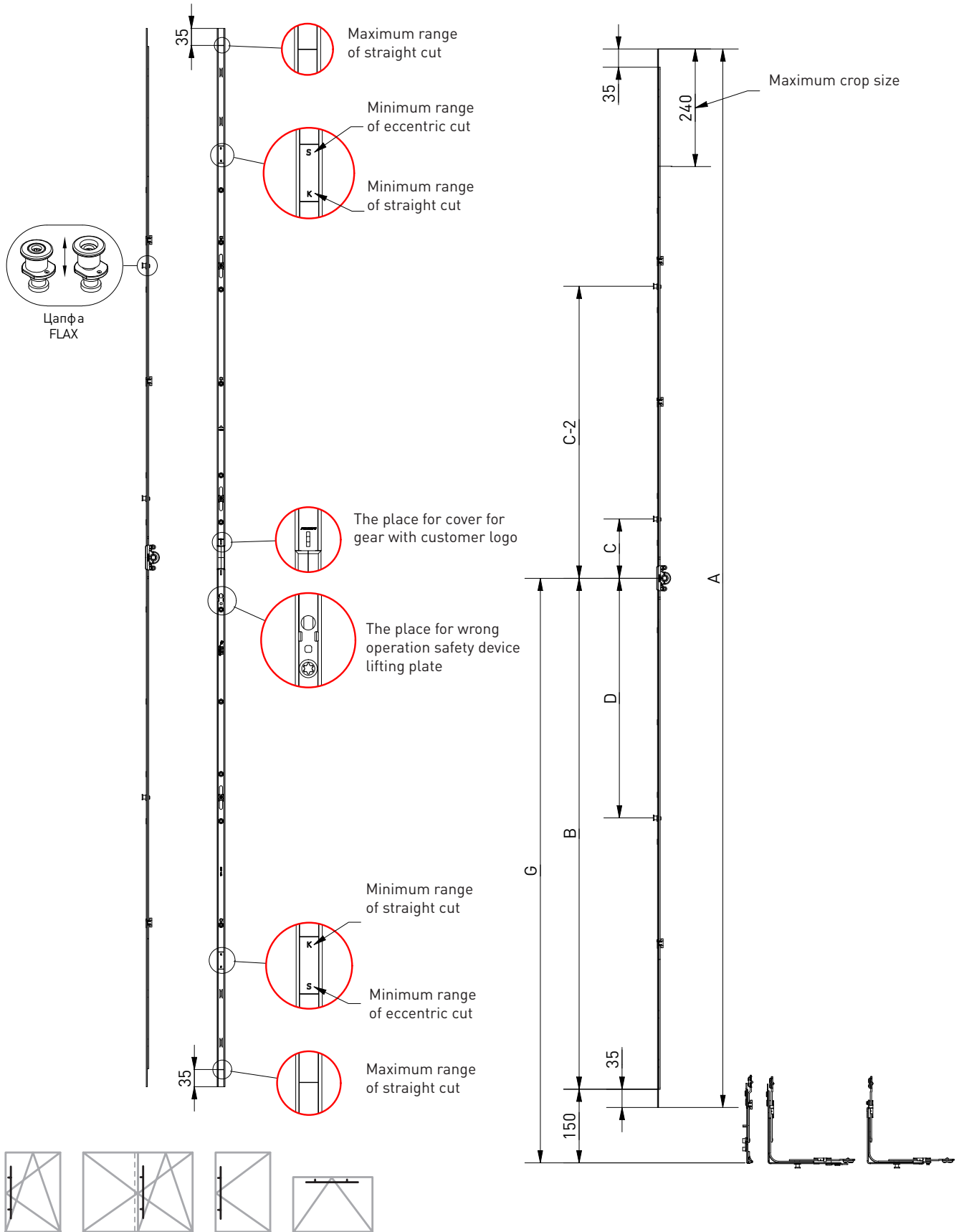

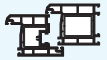

Tilt and turn variable gear handle position is central FLAX pin

Gears

Description	SRH (mm)	Dimensions									Part No.
		G	A	B	C	C-2	D				
Gear 2, L=1000, 751-1230, 1FX	751-1230	375-615	1000	465	120	—	—	1	4	20	K1104-09-N03
Gear 3, L=1200, 950-1430, 1FX	950-1430	475-715	1200	565	120	—	—	1	5	20	K1104-11-N03
Gear 3A, L=1200, 950-1430, 2FX	950-1430	475-715	1200	565	120	—	226	2	6	20	K1104-12-N03
Gear 4, L=1480, 1231-1710, 2FX	1231-1710	615-855	1480	705	120	—	290	2	6	20	K1104-14-N03
Gear 5, L=1680, 1431-1910, 2FX	1431-1910	715-955	1680	805	265	—	390	2	7	10	K1104-16-N03
Gear 6, L=2160, 1911-2390, 3FX	1911-2390	955-1195	2160	1045	120	595	490	3	11	10	K1104-21-N03

AXORTM

KOMFORT LINE K-3

Corner transmissions
Middle locks
Extensions

AXOR



Corner transmissions

FOR STRAIGHT CUT

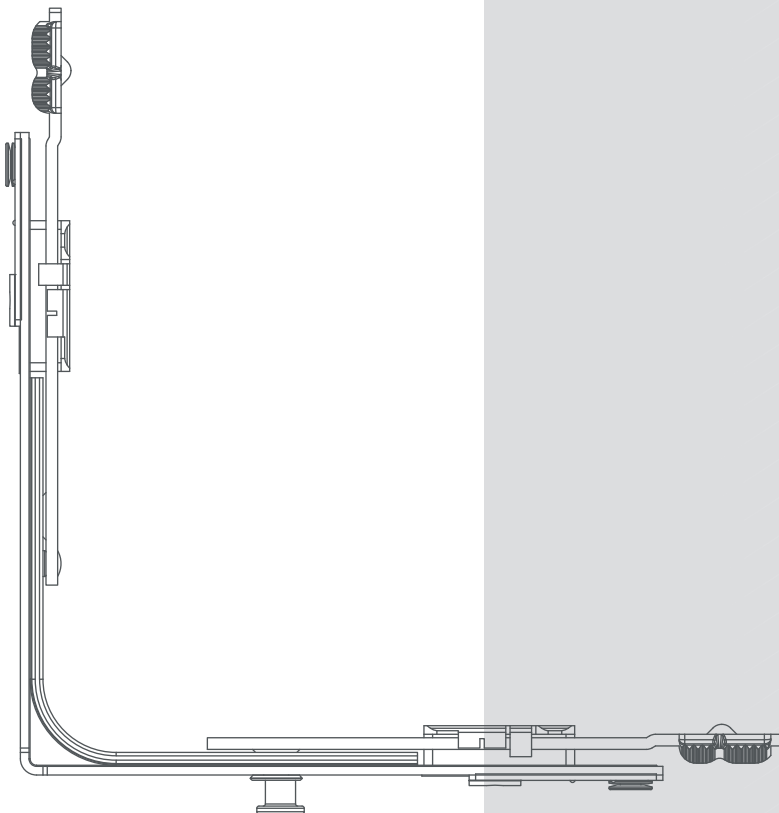



Corner transmissions

Corner transmissions
Middle locks

Corner transmission, 1 ML, 150×150

- not intended for RC security level.

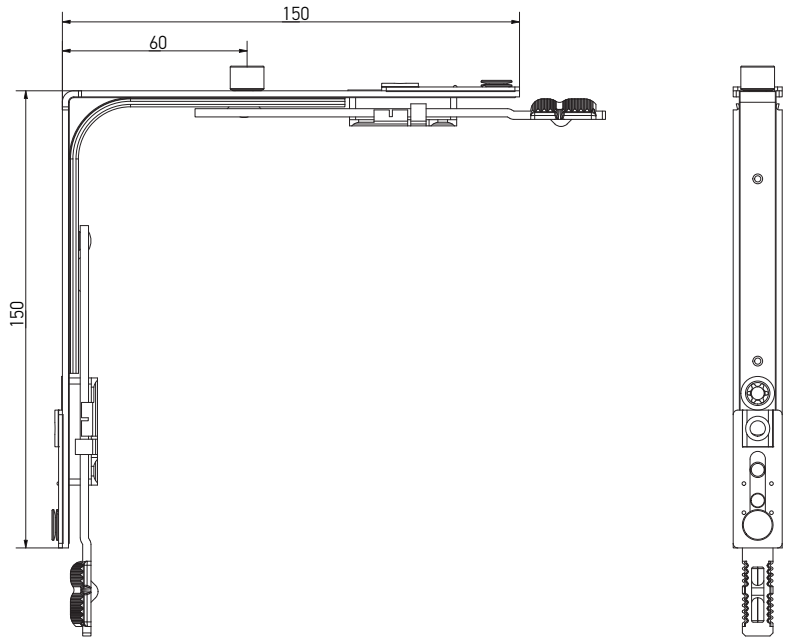
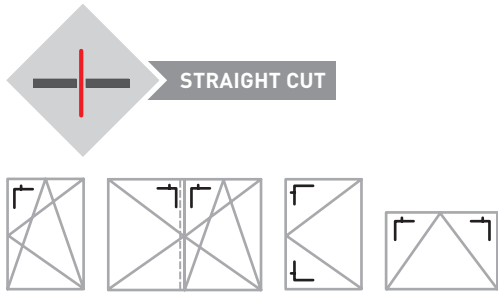

Corner transmission, 1 MR, 150×150

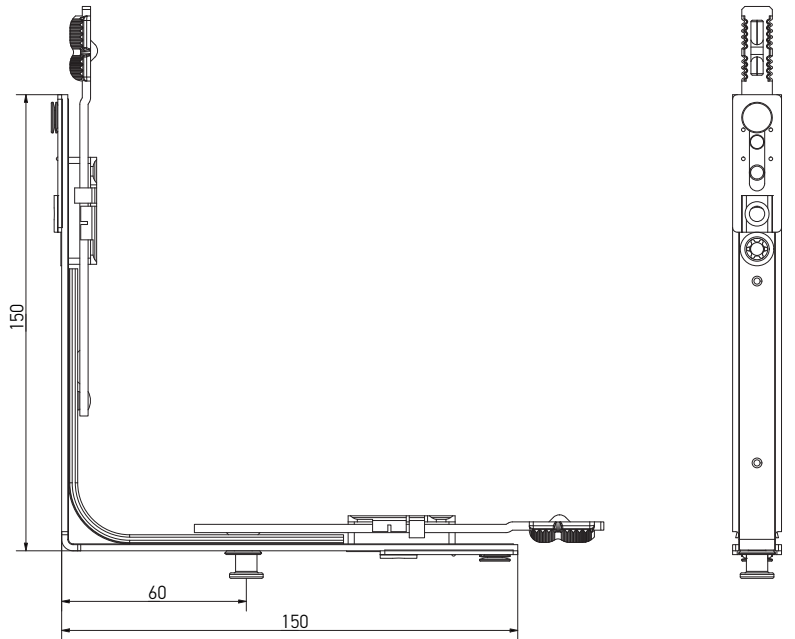
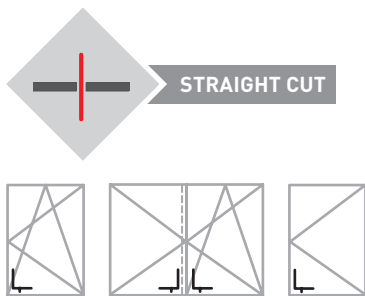

Description	Application range						Part No.
	SRW (mm)	SRH (mm)					
Corner transmission, 1 ML, 150×150	400-1280	450-2390	1	—	4	50	K2001-00-N03
Corner transmission, 1 MR, 150×150	400-1280	450-2390	—	1	4	50	K2005-00-N03
Corner transmission, 150×150, without locking pin	400-1280	450-2390	—	—	4	50	K2016-00-N03



Corner transmissions

Corner transmissions
Middle locks

Corner transmission, 2 ML, 150x150

- not intended for RC security level.

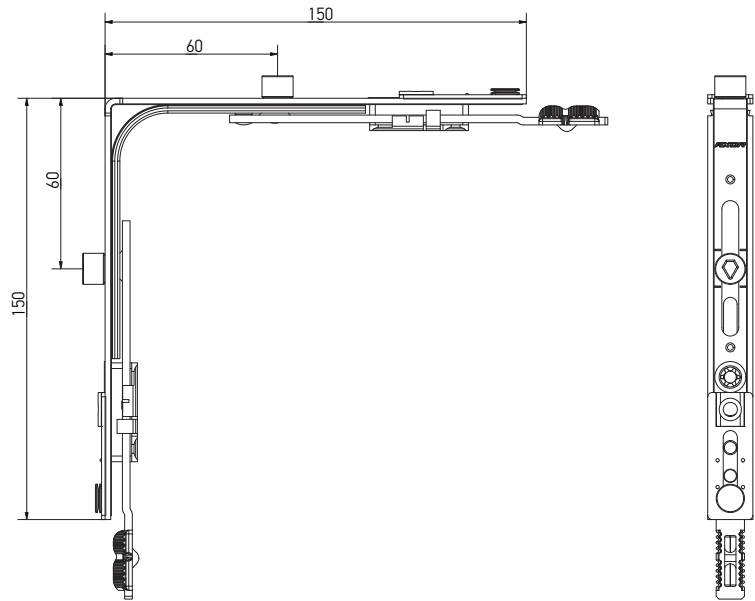
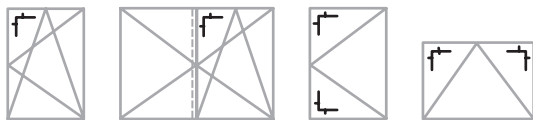
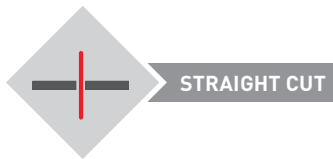

Corner transmission, 2 MR, 150x150

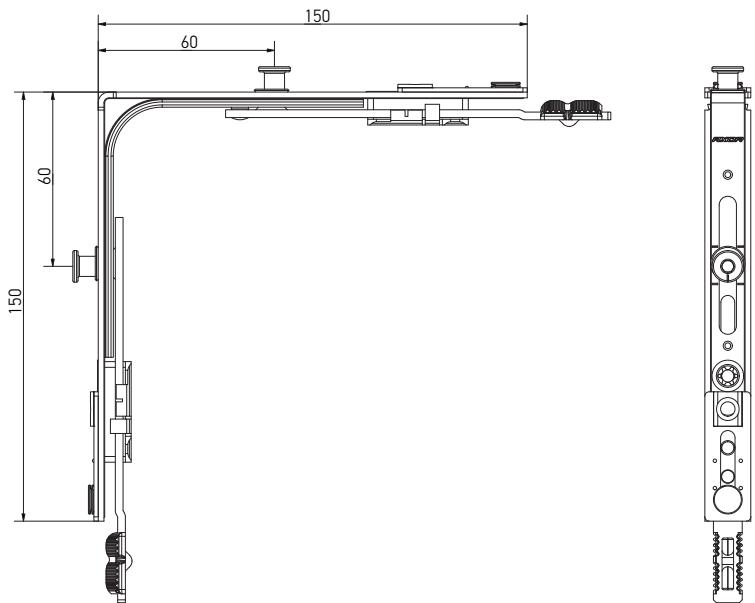
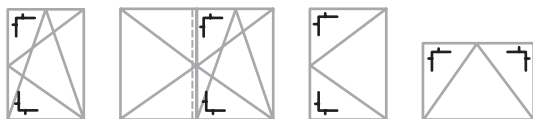
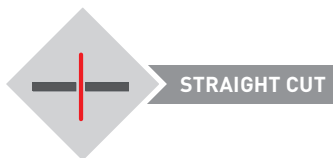

Description	Application range						Part No.
	SRW (mm)	SRH (mm)					
Corner transmission 2 ML, 150x150	400-1280	450-2390	2	—	4	50	K2002-00-N03
Corner transmission, 2 MR, 150x150	400-1280	450-2390	—	2	4	50	K2012-00-N03
Corner transmission, 1 MR, 1 ML, 150x150	400-1280	450-2390	1	1	4	50	K2013-00-N03
Corner transmission, 2 MR, 150x150, bottom	400-1280	450-2390	—	2	4	50	K2009-00-N03



Narrow corner transmission

Corner transmissions
Middle locks

Narrow corner transmission, 1 ML, 50x150

Narrow corner transmission, 1 MR, 50x150

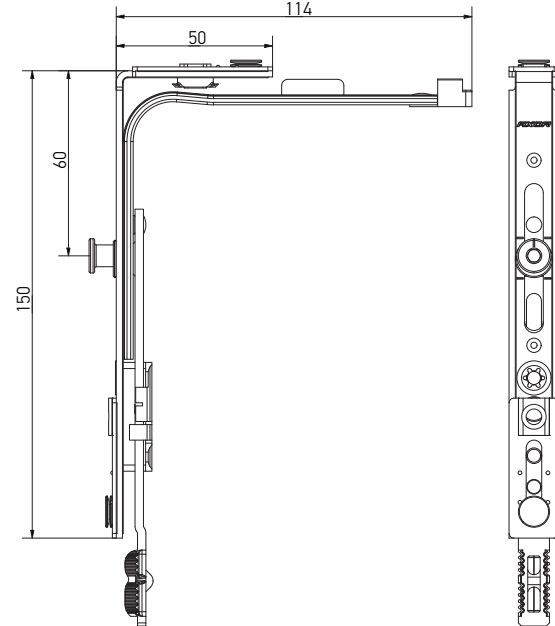
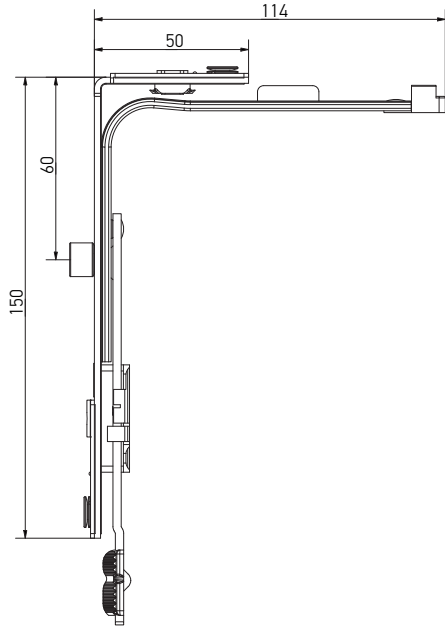

- not intended for double-sash windows;
- not intended for RC security level.

In order to use the narrow corner transmission according to scheme B the distance from the bottom of the fitting groove to the handle axis should be 225 mm, i.e. a hole for handle on gear K1001-02-N03 is displaced from the center of the sash in application range of the sash's height 370-450 mm.

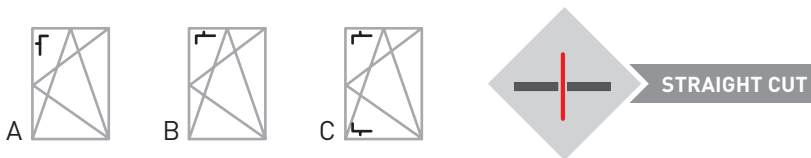

Description	Side opening	Application range						Part No.
		SRW (mm)	SRH (mm)					
Narrow corner transmission, 1 ML, 50x150	A	300-400	450-2390	1	—	3	50	K2003-00-N03
Narrow corner transmission, 1 ML, 50x150	B	400-600	370-450	1	—	3	50	K2003-00-N03
Narrow corner transmission, 1 MR, 50x150	A	300-400	450-2390	—	1	3	50	K2006-00-N03
Narrow corner transmission, 1 MR, 50x150	B	400-600	370-450	—	1	3	50	K2006-00-N03
Narrow corner transmission, 1 MR, 50x150	C	400-600	300-350	—	1	3	50	K2006-00-N03
Narrow corner transmission, without locking pin, 50x150	A	300-400	450-2390	—	—	3	50	K2017-00-N03
Narrow corner transmission, without locking pin, 50x150	B	400-600	370-450	—	—	3	50	K2017-00-N03



Corner transmission, integrated slit

Corner transmissions
Middle locks

Corner transmission, integrated slit, 1 ML, 150×150

- separate transmissions for left and right opening;
- provides 3 type-sizes of ventilation;
- Ventilation slit 12,16, 20 mm.

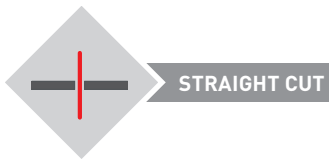
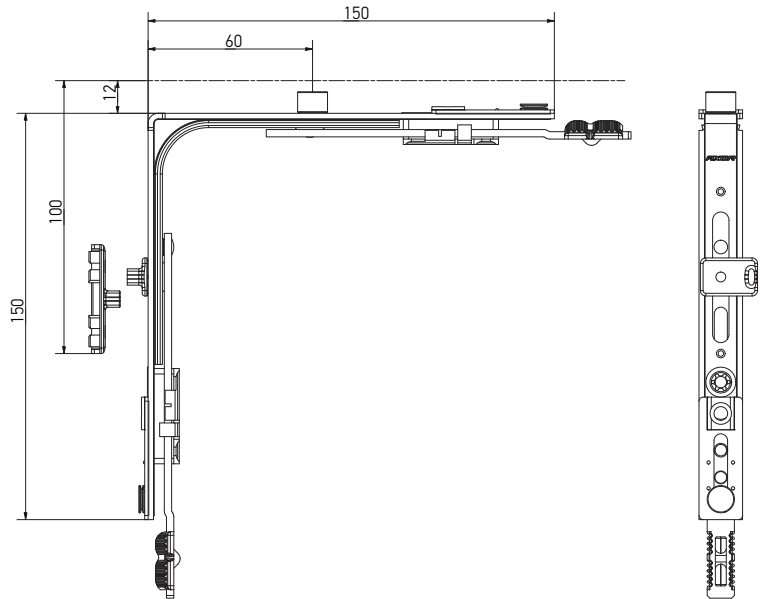

Corner transmission, integrated slit, 1 MR, 150×150

- separate transmissions for left and right opening;
- provides 3 type-sizes of ventilation;
- Ventilation slit 12,16, 20 mm.

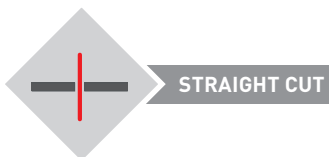
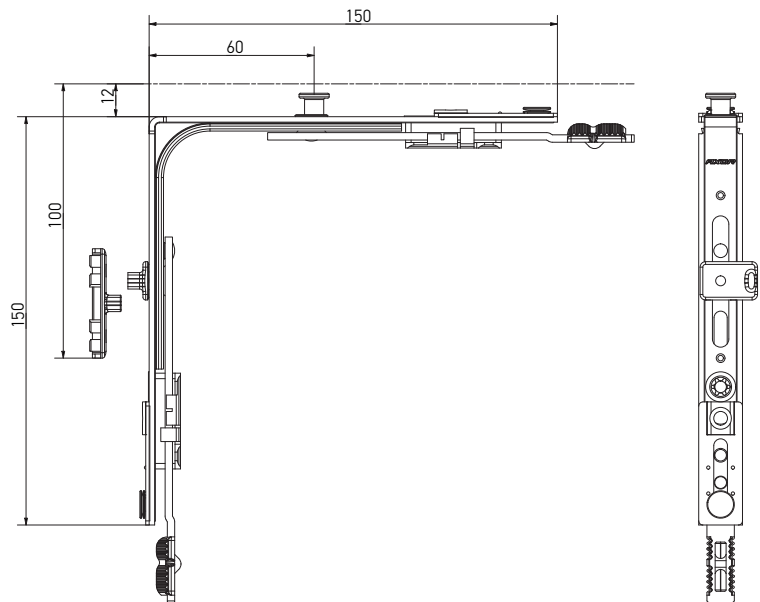

Description	Application range						Part No.
	SRW (mm)	SRH (mm)					
Corner transmission, integrated slit, 1 ML, 150×150, left	400-1280	450-2390	1	—	4	50	K2004-00-L03
Corner transmission, integrated slit, 1 ML, 150×150, right	400-1280	450-2390	1	—	4	50	K2004-00-R03
Corner transmission, integrated slit, 1 MR, 150×150, left	400-1280	450-2390	—	1	4	50	K2014-00-L03
Corner transmission, integrated slit, 1 MR, 150×150, right	400-1280	450-2390	—	1	4	50	K2014-00-R03

Locking plate for integrated slit (frame part)

look at the section “Profile-dependent elements”

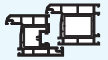

Corner transmission, double sash

Corner transmissions
Middle locks

Corner transmission, double sash, 1 ML, 150×150, top

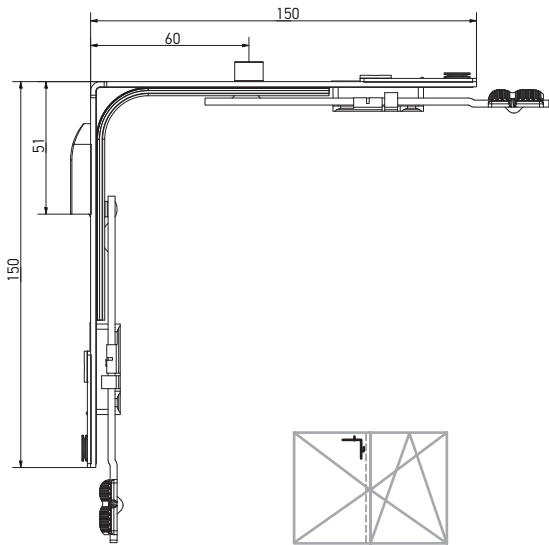

Corner transmission, double sash, 1 MR, 150×150, top

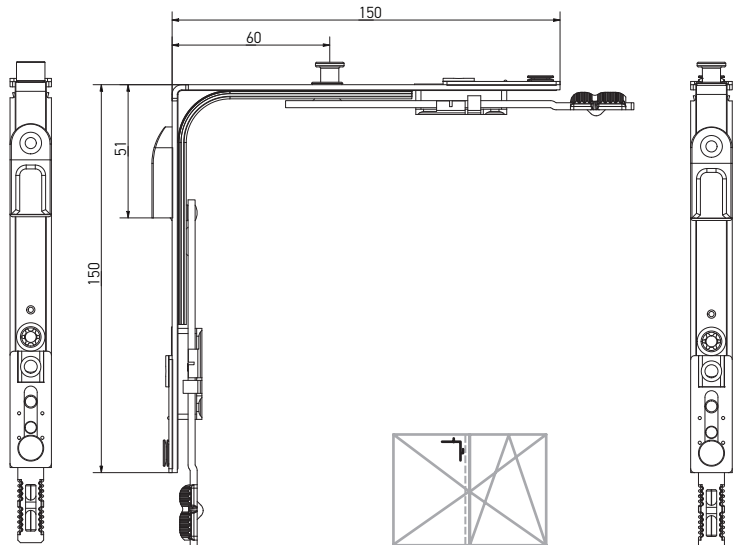

Corner transmission, double sash, 1 ML, 150×150, bottom

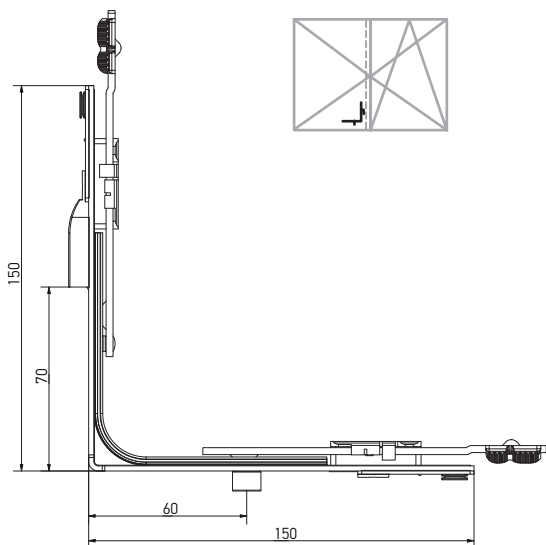

Corner transmission, double sash, 1 MR, 150×150, bottom

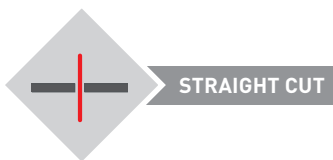
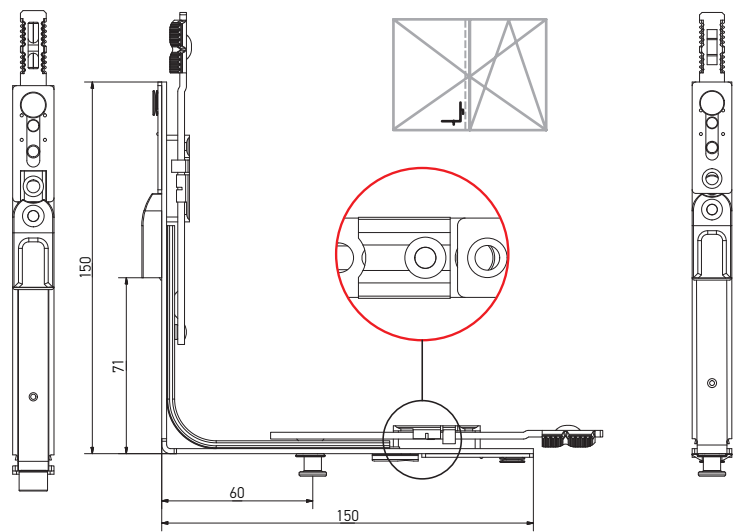

Description	Application range							Part No.
	SRW (mm)	SRH (mm)						
Corner transmission, double sash, 1 ML, 150×150, top	400-1280	450-2390	1	—	1	4	50	K2007-01-N03
Corner transmission, double sash, 1 ML, 150×150, bottom	400-1280	450-2390	1	—	1	4	50	K2007-02-N03
Corner transmission, double sash, 1 MR, 150×150, top	400-1280	450-2390	—	1	1	4	50	K2011-00-N03
Corner transmission, double sash, 1 MR, 150×150, bottom	400-1280	450-2390	—	1	1	4	50	K2010-00-N03



Corner transmission

Corner transmissions
Middle locks

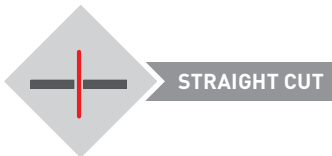
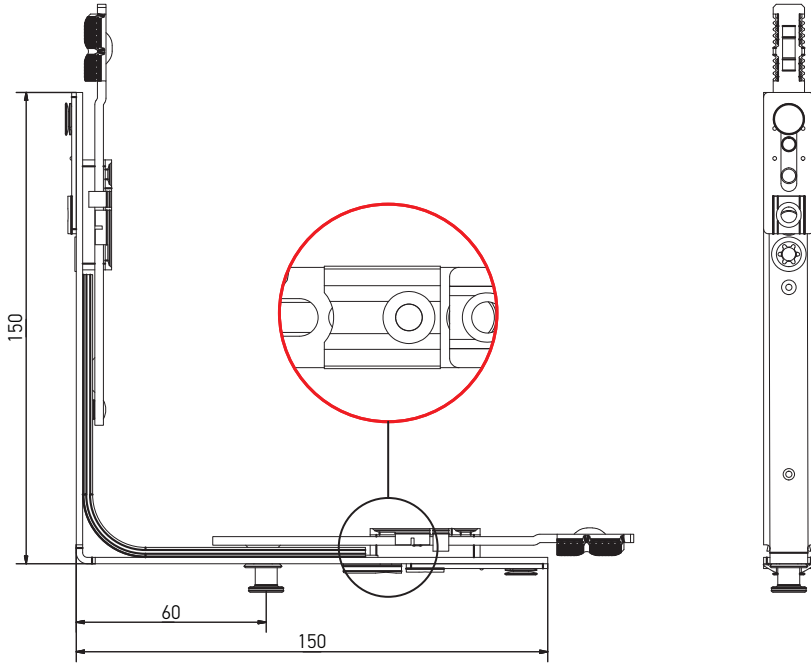

Description	Application range					Part No.
	SRW (mm)	SRH (mm)				
Corner transmission, 1 MR, 150×150, bottom	400-1280	450-2390	1	4	50	K2008-00-N03

**Corner transmission
for aluminium doorstep**

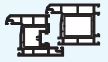

Corner transmission for aluminium doorstep, 1 MR, 150×150

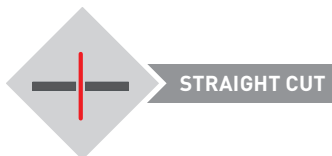
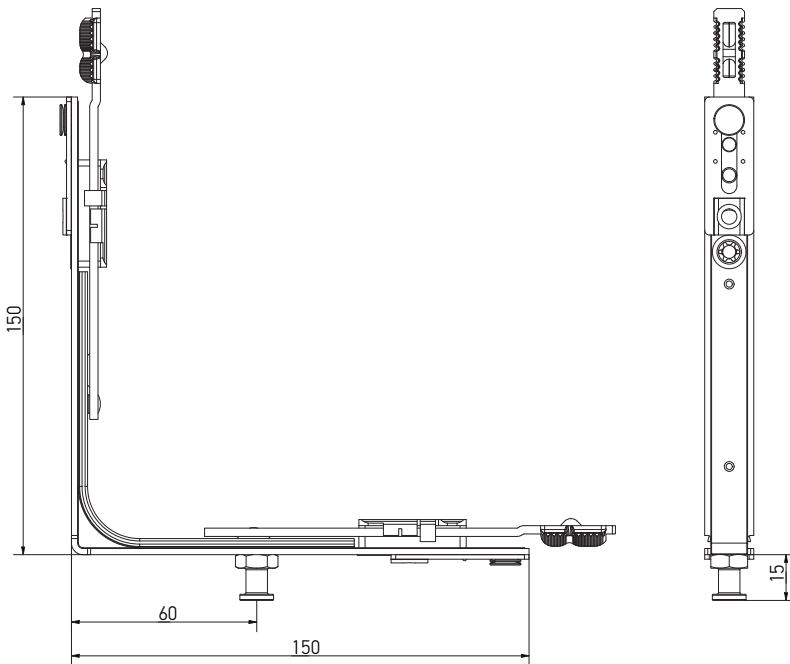

Description	Application range					Part No.
	SRW (mm)	SRH (mm)				
Corner transmission for aluminium doorstep, 1 MR, 150×150	400-1280	450-2390	1	4	50	K2015-00-N03

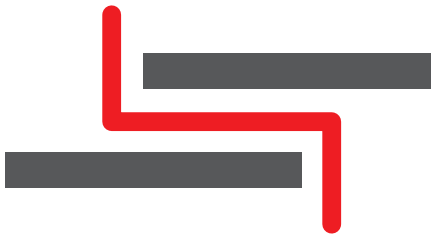

Corner transmissions

FOR ECCENTRIC CUT

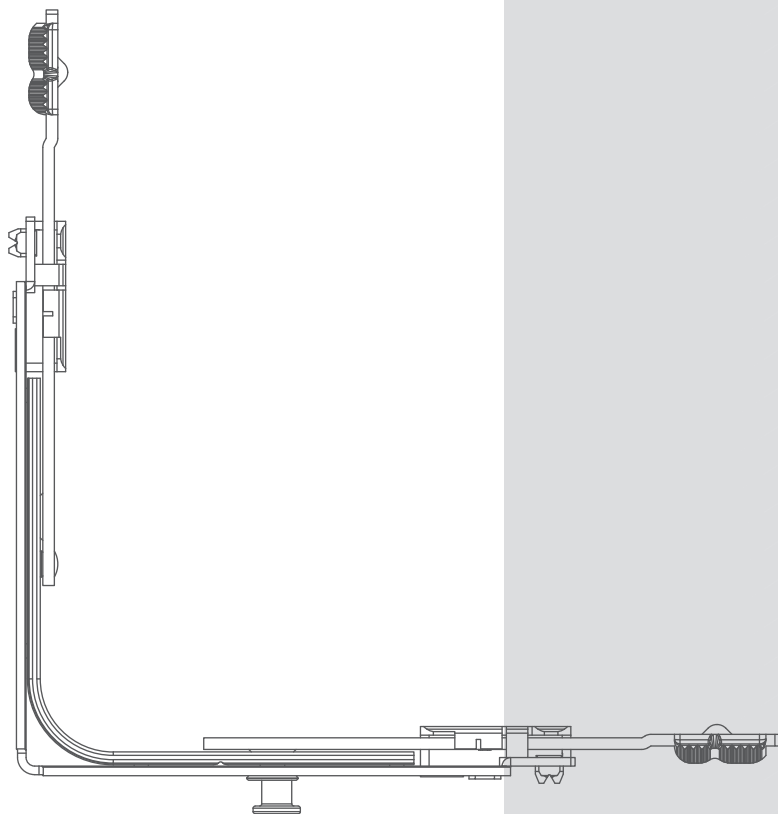

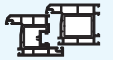

Corner transmissions

Corner transmissions
Middle locks

Corner transmission, 1 ML, 115×115

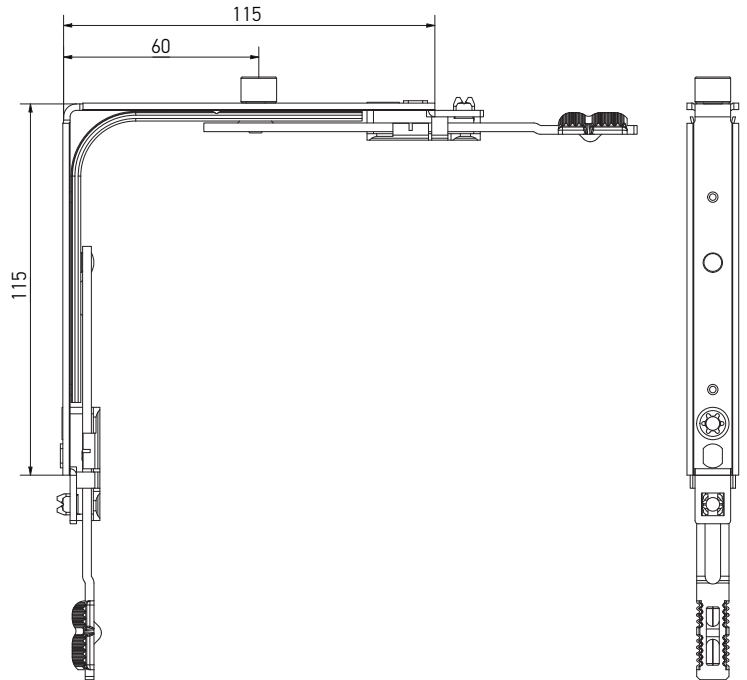

Corner transmission, 2 ML 115×115

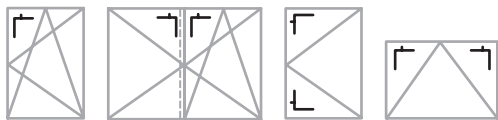
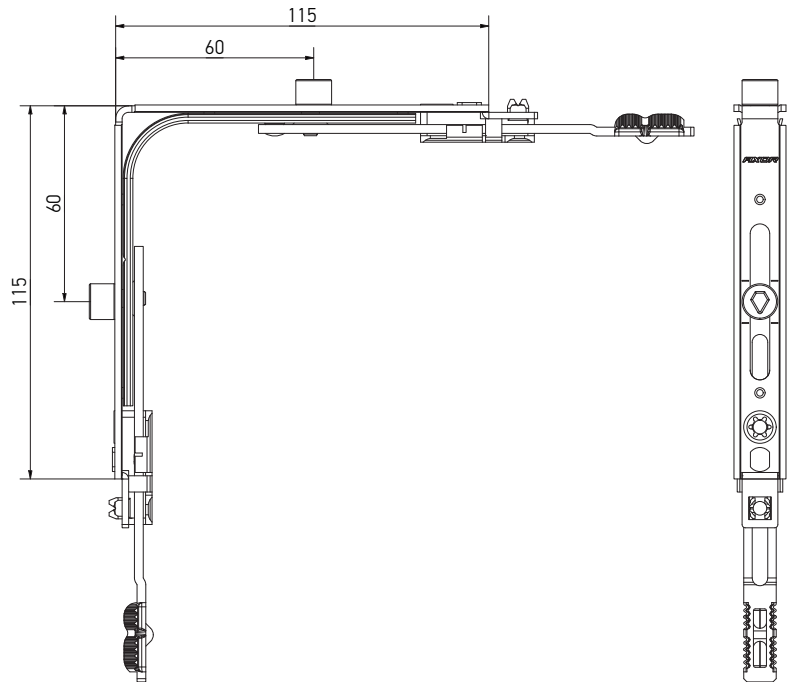

Description	Application range						Part No.
	SRW (mm)	SRH (mm)					
Corner transmission, 1 ML, 115×115	400-1280	450-2390	1	—	4	50	K2021-00-N03
Corner transmission, 2 ML, 115×115	400-1280	450-2390	2	—	4	50	K2022-00-N03
Corner transmission, without locking pin, 115×115	400-1280	450-2390	—	—	4	50	K2036-00-N03



Corner transmissions

Corner transmissions
Middle locks

Corner transmission, 1 MR, 115×115

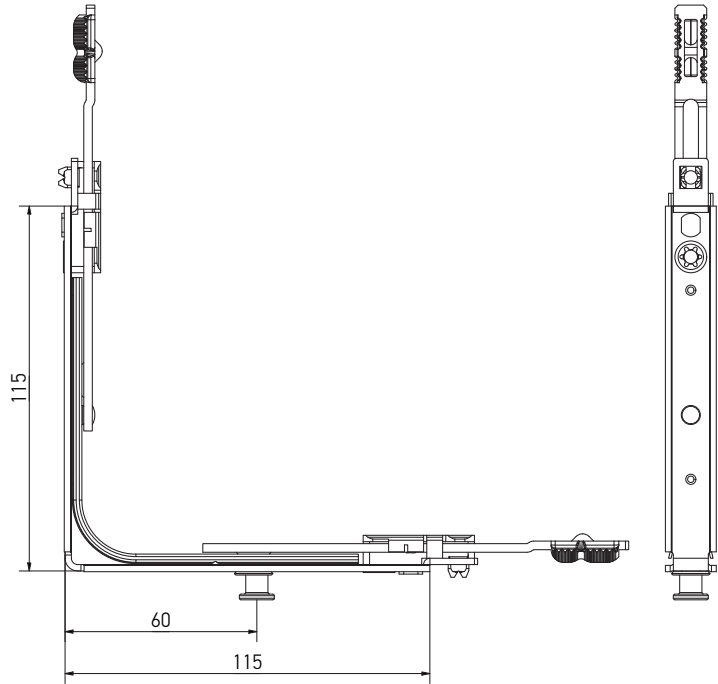

Corner transmission, 2 MR, 115×115

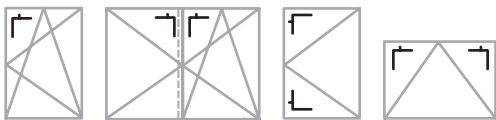
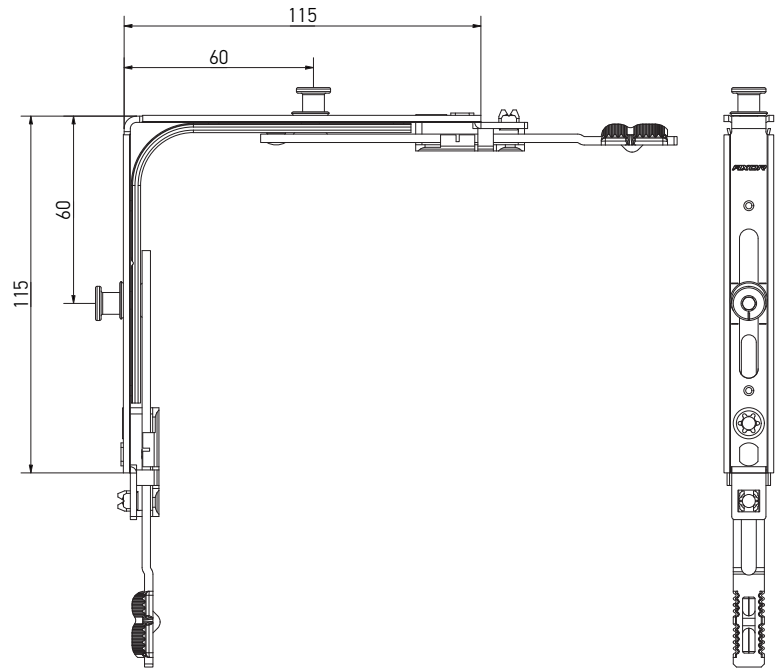

Description	Application range						Part No.
	SRW (mm)	SRH (mm)					
Corner transmission, 1 MR, 115×115	400-1280	450-2390	—	1	4	50	K2025-00-N03
Corner transmission, 2 MR, 115×115	400-1280	450-2390	—	2	4	50	K2032-00-N03
Corner transmission, 1 ML, 1 MR, 115x115	400-1280	450-2390	1	1	4	50	K2033-00-N03





Corner transmissions

Corner transmissions
Middle locks

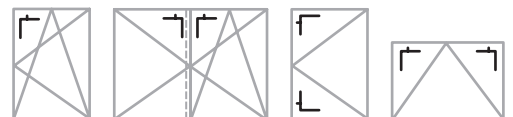
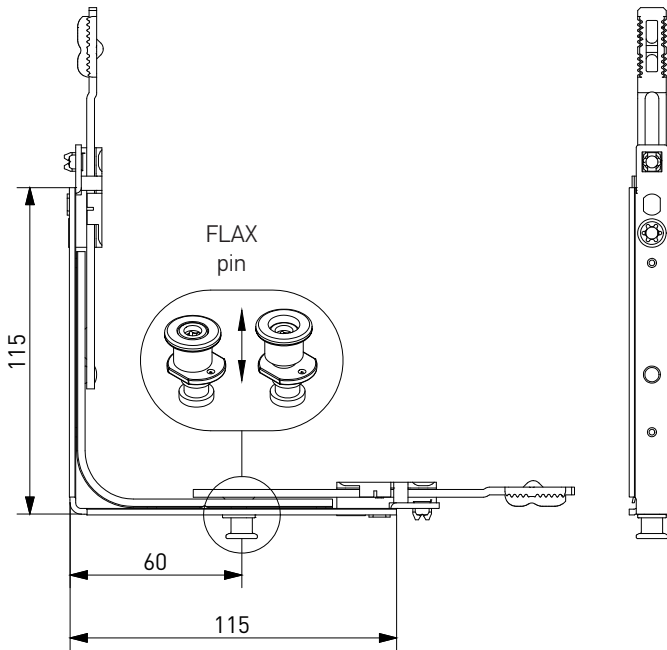
Corner transmission, 1FX, 115x115



Description	Application range					Part No.
	SRW (mm)	SRH (mm)				
Corner transmission, 1FX	400-1280	450-2390	1	4	50	K2055-00-N03



Corner transmissions

Corner transmissions
Middle locks

Corner transmission, bottom, 1 MR, 115×115

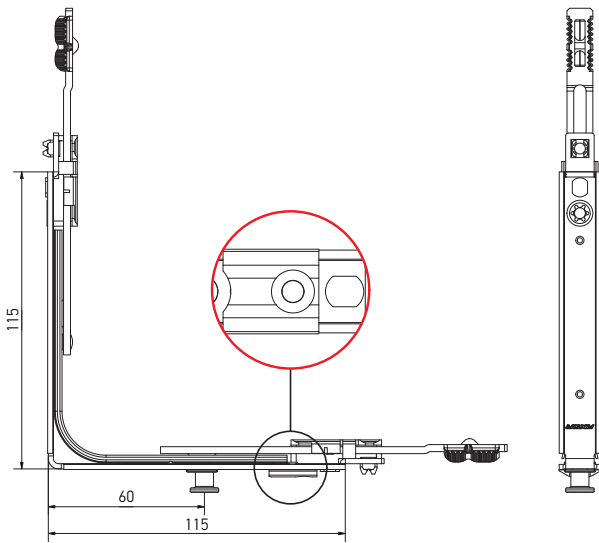

Corner transmission, bottom, 2 MR, 115×115

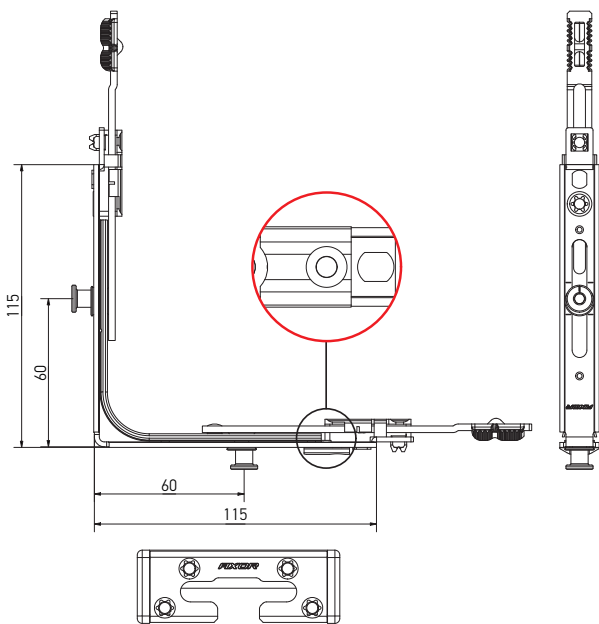

Description	Application range						Part No.
	SRW (mm)	SRH (mm)					
Corner transmission, bottom, 1 MR, 115×115	400-1280	450-2390	—	1	4	50	K2028-00-N03
Corner transmission, bottom, 2 MR, 115×115	400-1280	450-2390	—	2	4	50	K2029-00-N03

Corner transmissions

Corner transmissions
Middle locks

Corner transmission, bottom, 1FX

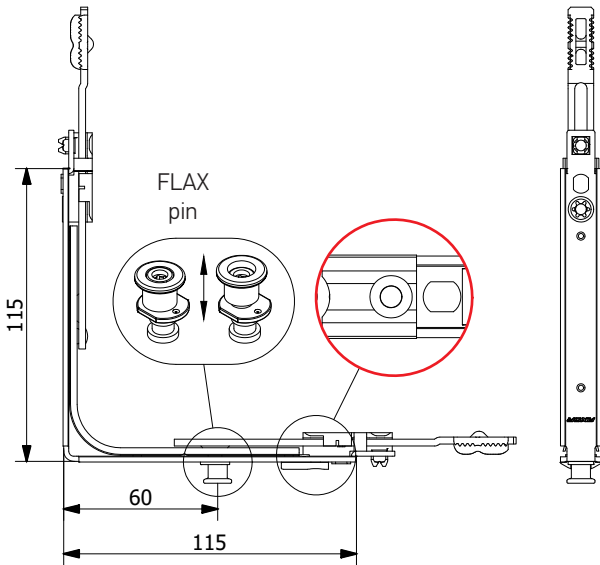



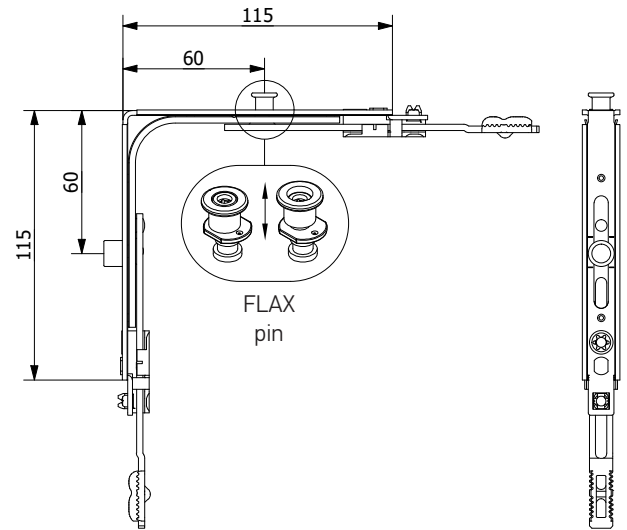

Corner transmission, bottom, 1FX +MAGNET

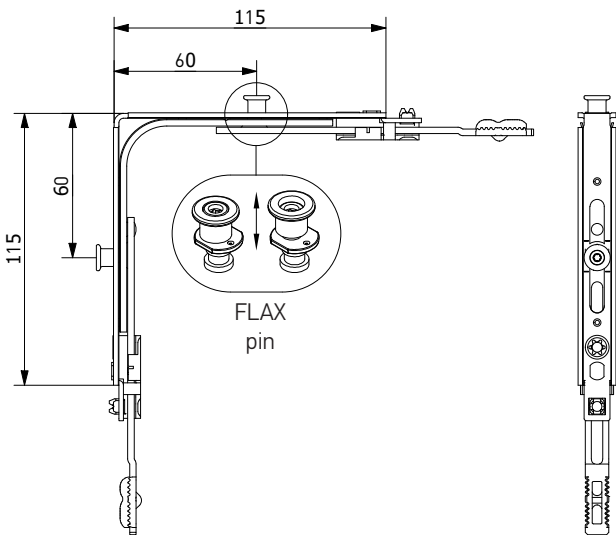

Corner transmission, bottom, 2FX



Description	Application range						Part No.
	SRW (mm)	SRH (mm)					
Corner transmission, bottom, 1FX	400-1280	450-2390	-	1	4	50	K2058-00-N03
Corner transmission, bottom, 2FX	400-1280	450-2390	-	2	4	50	K2062-00-N03
Corner transmission, bottom 115x115, 1FX+MAGNET	400-1280	450-2390	1	1	4	50	K2070-00-N03



Narrow corner transmission

Corner transmissions
Middle locks

Narrow corner transmission, 1 ML, 15×115

Narrow corner transmission, 1 MR, 115×15

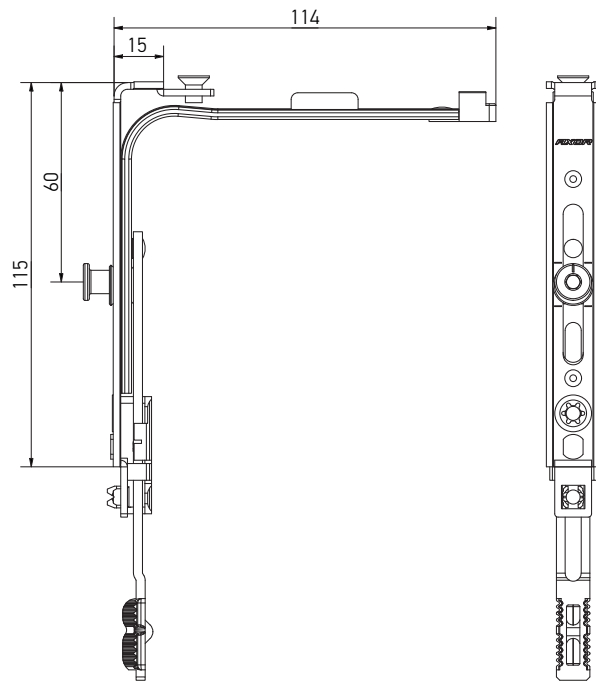
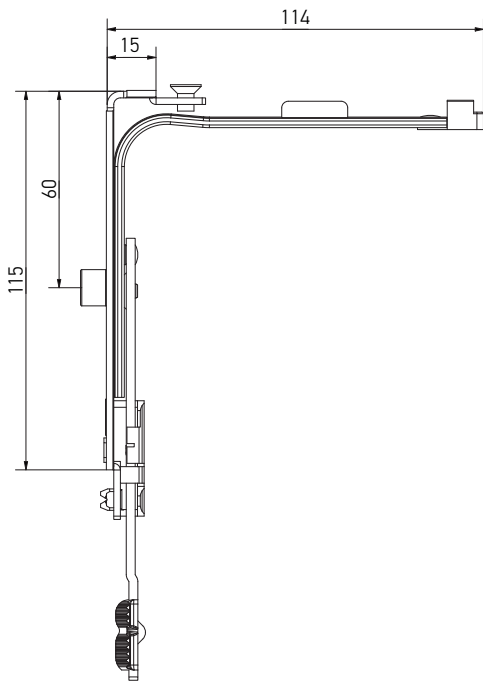

- not intended for double-sash windows

In order to use the narrow corner transmission according to scheme B the distance from the bottom of the fitting groove to the handle axis should be 225 mm, i.e. a hole for handle on gear K1001-02-N03 is displaced from the center of the sash in application range of the sash's height 370-450 mm.

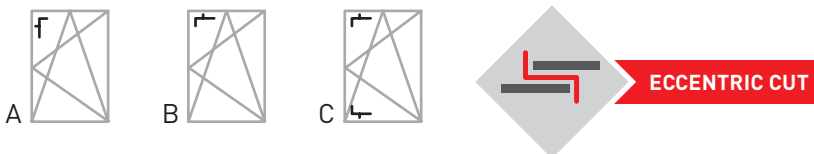

Description	Side opening	Application range						Part No.
		SRW (mm)	SRH (mm)					
Narrow corner transmission, 1 ML, 115×15	A	300-400	450-2390	1	—	3	50	K2023-00-N03
Narrow corner transmission, 1 ML, 115×15	B	400-600	370-450	1	—	3	50	K2023-00-N03
Narrow corner transmission, 1 MR, 115×15	A	300-400	450-2390	—	1	3	50	K2026-00-N03
Narrow corner transmission, 1 MR, 115×15	B	400-600	370-450	—	1	3	50	K2026-00-N03
Narrow corner transmission, 1 MR, 115×15	C	400-600	300-350	—	1	3	50	K2026-00-N03
Narrow corner transmission, without locking pin, 115×15	A	300-400	450-2390	—	—	3	50	K2037-00-N03
Narrow corner transmission, without locking pin, 115×15	B	400-600	370-450	—	—	3	50	K2037-00-N03

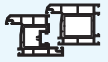

Narrow corner transmission

Corner transmissions
Middle locks

Narrow corner transmission, 1FX, 15x115

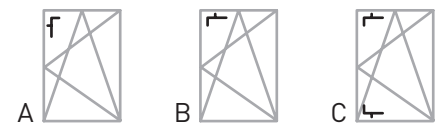
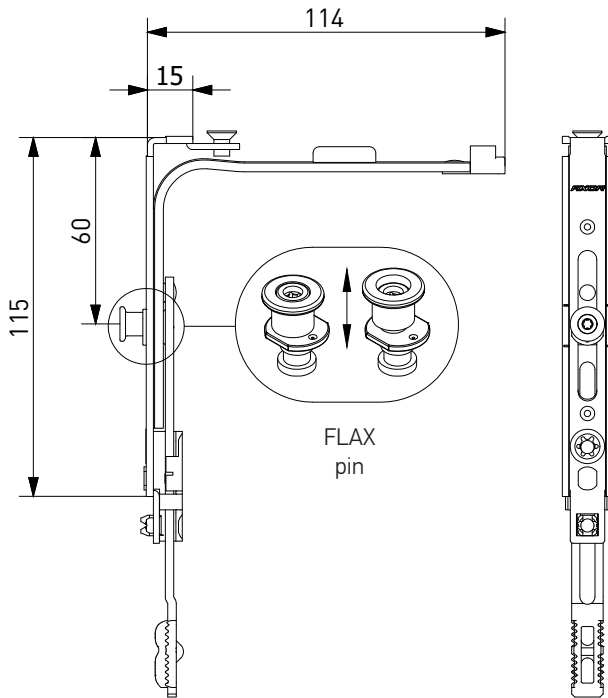

Description	Side opening	Application range					Part No
		SRW (mm)	SRH (mm)				
Narrow corner transmission 15x115, 1FX	A	300-400	450-2390	1	3	50	K2056-00-N03
Narrow corner transmission 15x115, 1FX	B	400-600	370-450	1	3	50	K2056-00-N03
Narrow corner transmission 15x115, 1FX	C	400-600	300-350	1	3	50	K2056-00-N03



Corner transmission, integrated slit

Corner transmissions
Middle locks

Corner transmission, integrated slit, 1 ML, 115×115

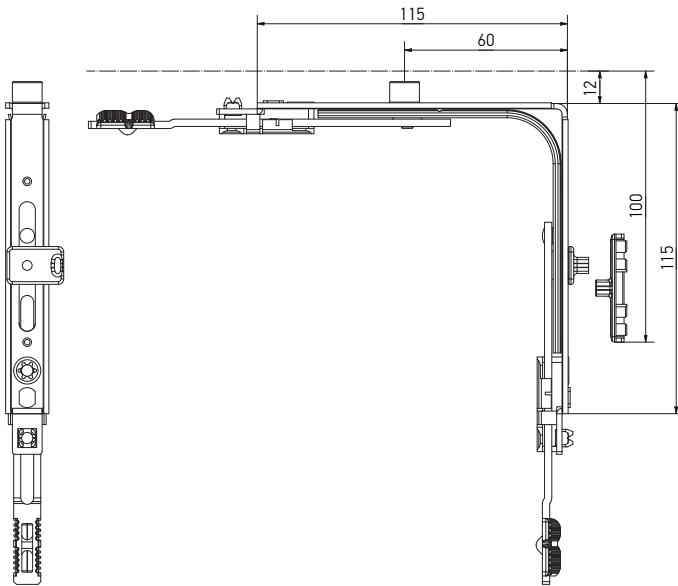

Corner transmission, integrated slit, 1 MR, 115×115

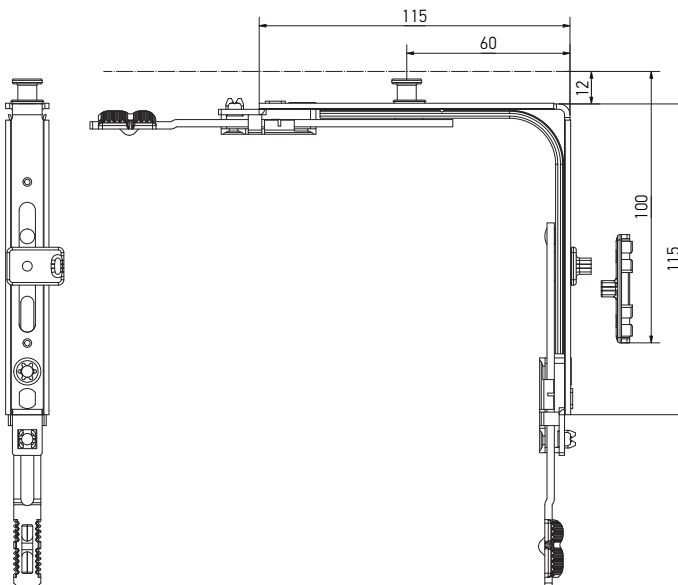

Description	Application range						Part No.
	SRW (mm)	SRH (mm)					
Corner transmission, integrated slit, 1 ML, left, 115×115	400-1280	450-2390	1	—	4	50	K2024-00-L03
Corner transmission, integrated slit, 1 ML, right, 115×115	400-1280	450-2390	1	—	4	50	K2024-00-R03
Corner transmission, integrated slit, 1 MR, 115×115, left	400-1280	450-2390	—	1	4	50	K2034-00-L03
Corner transmission, integrated slit, 1 MR, 115×115, right	400-1280	450-2390	—	1	4	50	K2034-00-R03

Locking plate for integrated slit (frame part)

look at the section "Profile-dependent elements"



Corner transmission, integrated slit

Corner transmissions
Middle locks

Corner transmission, integrated slit, 1 FX, 115x115

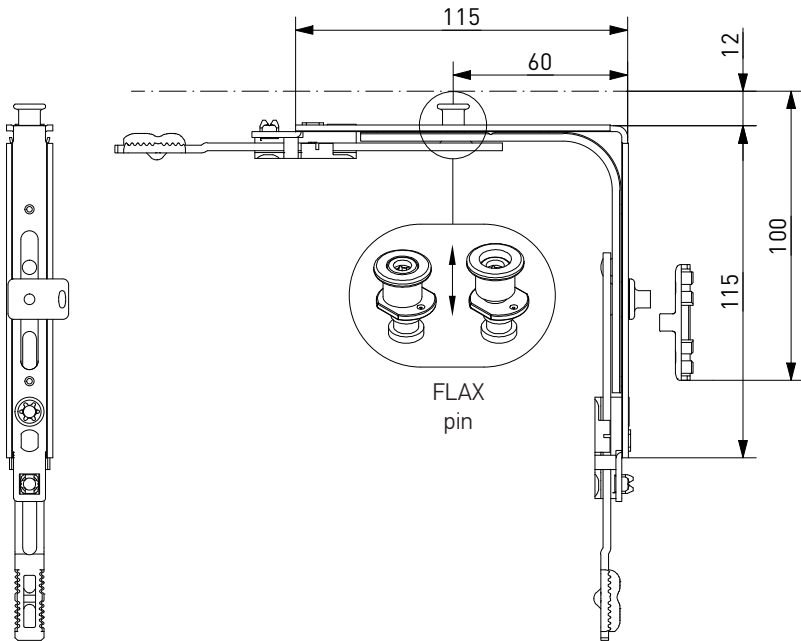

Description	Application range					Part No.
	SRW (mm)	SRH (mm)				
Corner transmission, integrated slit, 115x115, 1FX, left	400-1280	450-2390	1	4	50	K2054-00-L03
Corner transmission, integrated slit, 115x115, 1FX, right	400-1280	450-2390	1	4	50	K2054-00-R03

Locking plate for integrated slit (frame part)

look at the section "Profile-dependent elements"



Corner transmission, double sash

Corner transmissions
Middle locks

Corner transmission, double sash, 1 ML, 115×115, top

Corner transmission, double sash, 1 MR, 115×115, top

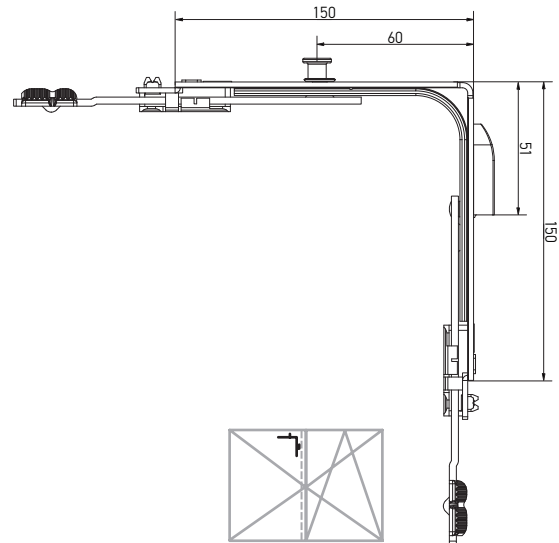
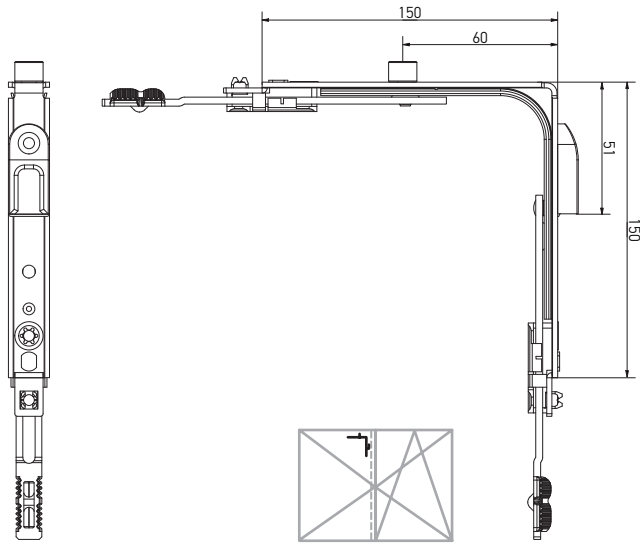

Corner transmission, double sash, 1 ML, 115×115, bottom

Corner transmission, double sash, 1 MR, 115×115, bottom

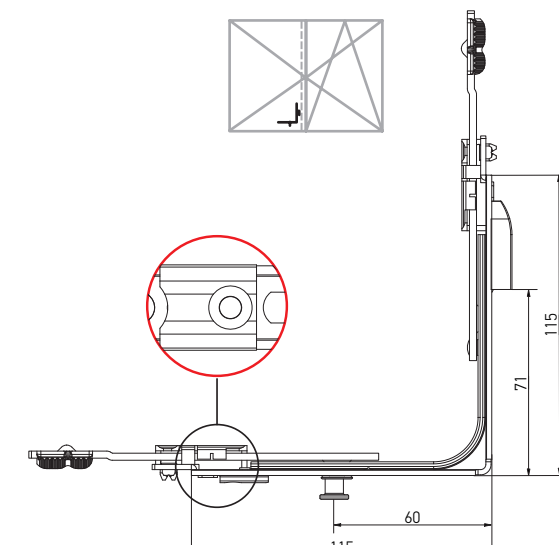
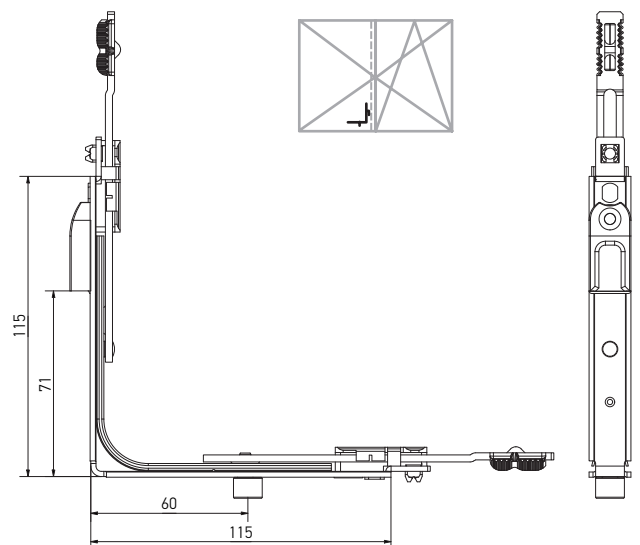

Description	Application range							Part No.
	SRW (mm)	SRH (mm)						
Corner transmission, double sash, 1 ML, 115×115, top	400-1280	450-2390	1	—	1	4	50	K2027-01-N03
Corner transmission, double sash, 1 MR, 115×115, top	400-1280	450-2390	—	1	1	4	50	K2031-00-N03
Corner transmission, double sash, 1 ML, 115×115, bottom	400-1280	450-2390	1	—	1	4	50	K2027-02-N03
Corner transmission, double sash, 1 MR, 115×115, bottom	400-1280	450-2390	—	1	1	4	50	K2030-00-N03

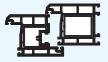

Corner transmission for aluminium doorstep, 1 MR, 115×115

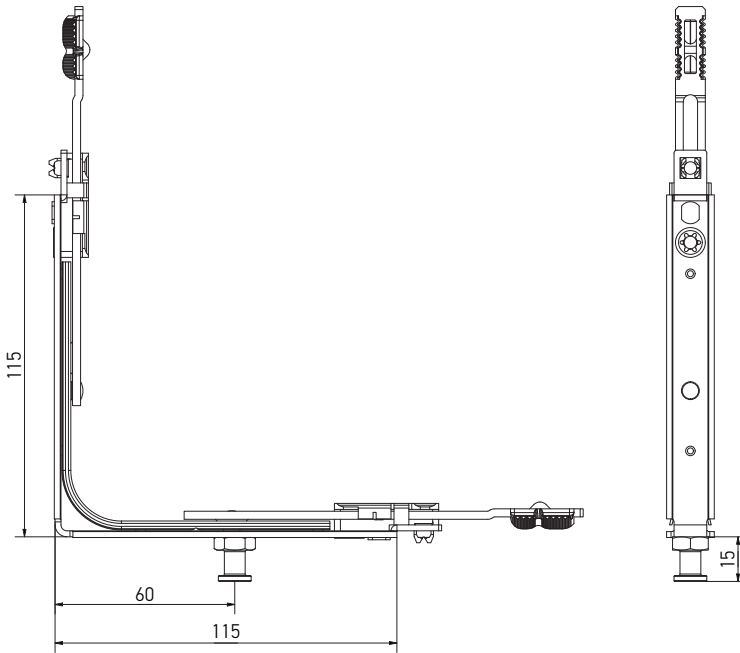

Description	Application range					Part No.
	SRW (mm)	SRH (mm)				
Corner transmission for aluminium doorstep, 1 MR, 115×115	400-1280	450-2390	1	4	50	K2035-00-N03



Middle lock

Corner transmissions
Middle locks

Middle lock

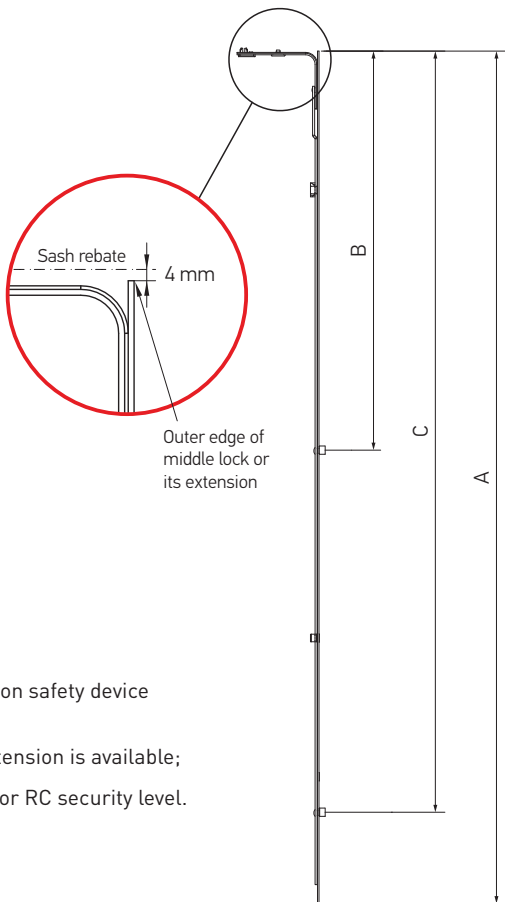

- wrong operation safety device is necessary;
- addition of extension is available;
- not intended for RC security level.

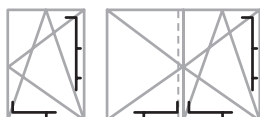

Middle lock extension, 1 ML, 480 mm

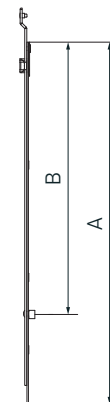

Middle lock extension, 1 ML, 680 mm

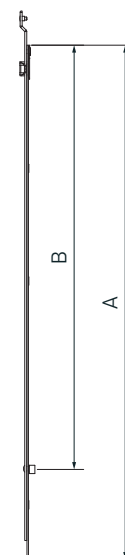

- for additional locking point;
- for height > 1710 mm.

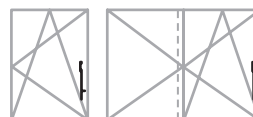

Description	SRH (mm)	SRW (mm)	Dimensions			Cylinder	Screw	Box	Part No.
			A	B*	C*				
Middle lock L=400, 1 ML	600-1000	600-1000	400	280	—	1	3	20	K4001-04-N03
Middle lock L=650, 1 ML	850-1250	850-1250	650	530	—	1	5	20	K4001-06-N03
Middle lock L=720, 1 ML	920-1320	920-1320	720	600	—	1	5	20	K4001-07-N03
Middle lock L=820, 1 ML	1251-1430	1251-1430	820	700	—	1	5	20	K4001-08-N03
Middle lock L=1130, 2 ML	1251-1730	—	1130	530	1010	2	8	20	K4001-11-N03

Description	SRH (mm)	SRW (mm)	Dimensions			Cylinder	Screw	Box	Part No.
			A	B	C				
Middle lock extension, 1 ML, 480 mm	1710-2210	1280-1520	480	360	—	1	4	20	K4005-05-N03
Middle lock extension, 1 ML, 680 mm	2211-2390	—	680	560	—	1	5	20	K4005-07-N03

*Dimensions B and C are distances from the outer edge of middle lock or its extension to the locking pin axis



Middle lock

Corner transmissions
Middle locks

Middle lock

**Middle lock extension,
1 MR, 480 mm**

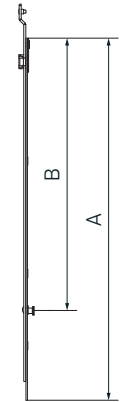
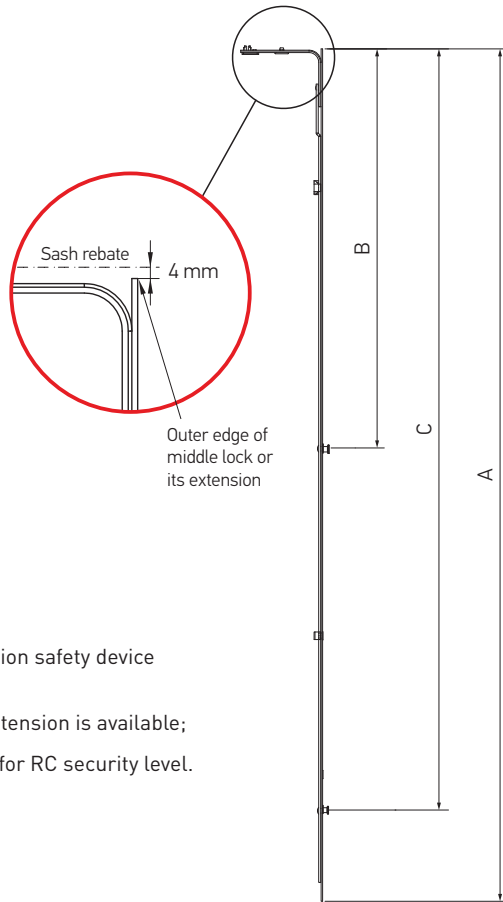

**Middle lock extension,
1 MR, 680 mm**

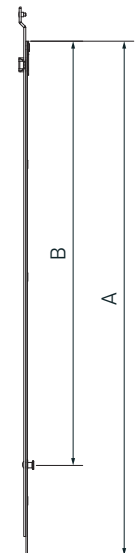

- wrong operation safety device is necessary;
- addition of extension is available;
- not intended for RC security level.

- for additional locking point;
- for height > 1710 mm.

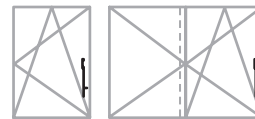
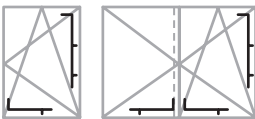

Description	SRH (mm)	SRW (mm)	Dimensions						Part No.
			A	B*	C*				
Middle lock L=400, 1 MR	600-1000	600-1000	400	280	—	1	3	20	K4017-04-N03
Middle lock L=650, 1 MR	850-1250	850-1250	650	530	—	1	5	20	K4017-06-N03
Middle lock L=820, 1 MR	1251-1430	1251-1430	820	700	—	1	5	20	K4017-08-N03
Middle lock L=1130, 2 MR	1251-1730	—	1130	530	1010	2	8	20	K4017-11-N03
Description	SRH (mm)	SRW (mm)	Dimensions						Part No.
			A	B	C				
Middle lock extension, 1 MR, 480 mm	1710-2210	1280-1520	480	360	—	1	4	20	K4025-05-N03
Middle lock extension, 1 MR, 680 mm	2211-2390	—	680	560	—	1	5	20	K4025-07-N03

*Dimensions B and C are distances from the outer edge of middle lock or its extension to the locking pin axis



Middle lock, FLAX pin

Corner transmissions
Middle locks

Middle lock, FX

Middle lock extension, 1FX, 480 mm

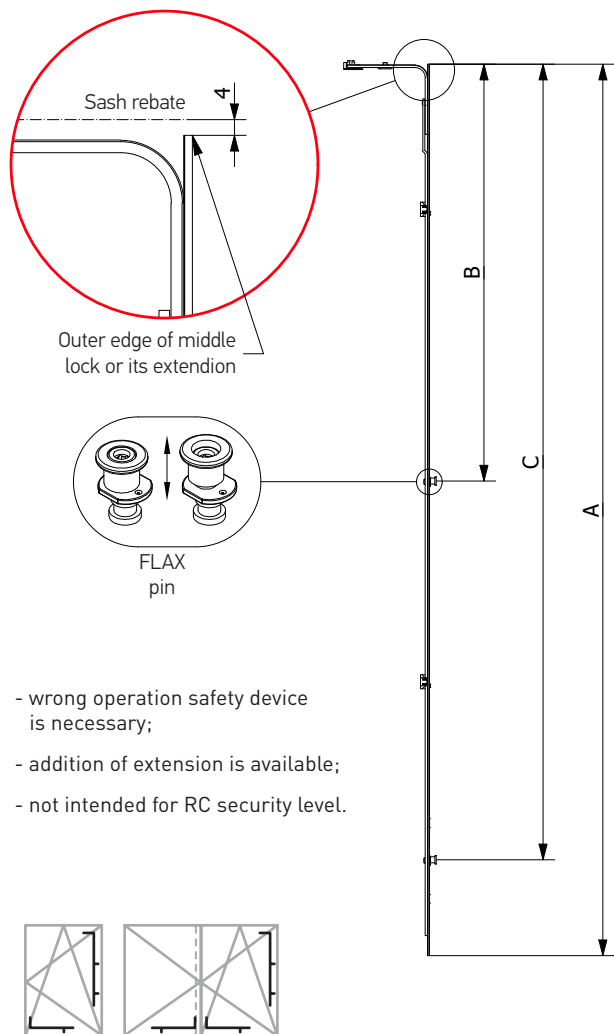

- wrong operation safety device is necessary;
- addition of extension is available;
- not intended for RC security level.

Middle lock extension, 1FX, 680 mm

- for additional locking point;
- for height > 1710 mm.

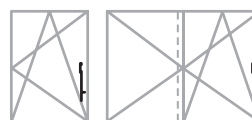

Description	SRH (mm)	SRW (mm)	Dimensions						Part No.
			A	B	C				
Middle lock L=400, 600-1000, 1FX	600-100	600-100	400	280	—	1	3	20	K4079-04-N03
Middle lock L=650, 850-1250, 1FX	850-1250	850-1250	650	530	—	1	5	20	K4079-06-N03
Middle lock L=820, 1251-1430, 1FX	1251-1430	1251-1430	820	700	—	1	5	20	K4079-08-N03
Middle lock L=1130, 1251-1730, 2FX	1251-1730	—	1130	530	1010	2	8	20	K4079-11-N03

Description	SRH (mm)	SRW (mm)	Dimensions					Part No.
			A	B				
Middle lock extension 480 mm, 1711-2210, 1FX	1710-2210	1280-1520	480	360	1	4	20	K4075-05-N03
Middle lock extension 680 mm, 2211-2390, 1FX	2211-2390	—	680	560	1	5	20	K4075-07-N03

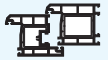

Middle lock, 2ML

Corner transmissions
Middle locks

Middle lock, 2ML

Middle lock extension, 1 ML, 480 mm

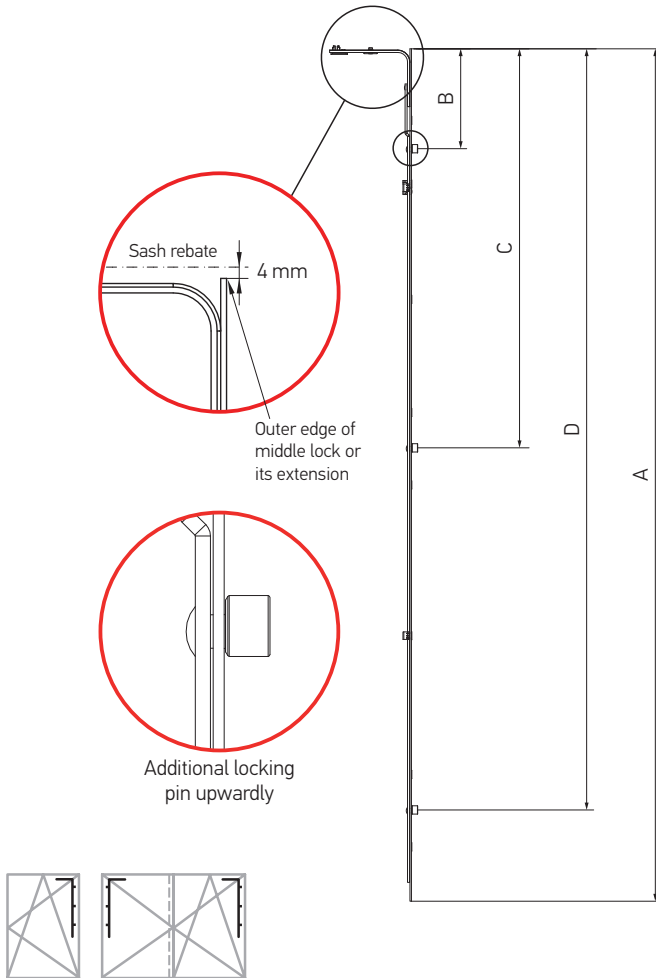

Middle lock extension, 1 ML, 680 mm

- for additional locking point;
- for height > 1710 mm.

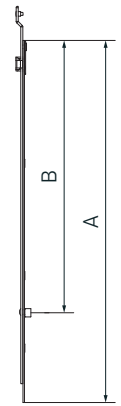
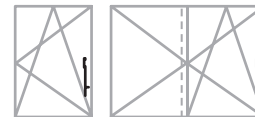

Description	SRH (mm)	SRW (mm)	Dimensions							Part No.
			A	B*	C*	D*				
Middle lock, L=400, 2 ML	600-1000	600-1000	400	132	280	—	2	3	20	K4004-04-N03
Middle lock, L=650, 2 ML	850-1250	850-1250	650	132	530	—	2	5	20	K4004-06-N03
Middle lock, L=720, 2 ML	920-1320	920-1320	720	132	600	—	2	5	20	K4004-07-N03
Middle lock, L=820, 2 ML	1251-1430	1251-1430	820	132	700	—	2	5	20	K4004-08-N03
Middle lock, L=1130, 3 ML	1251-1730	—	1130	132	530	1010	3	8	20	K4004-11-N03

Description	SRH (mm)	SRW (mm)	Dimensions						Part No.
			A	B	C				
Middle lock extension, 1 ML, 480 mm	1710-2210	1280-1520	480	360	—	1	4	20	K4005-05-N03
Middle lock extension, 1 ML, 680 mm	2211-2390	—	680	560	—	1	5	20	K4005-07-N03

* Dimensions B, C and D are distances from the outer edge of middle lock or its extension to the locking pin axis 99



Middle lock, 2 MR

Corner transmissions
Middle locks

Middle lock, 2 MR

Middle lock extension, 1 MR, 480 mm

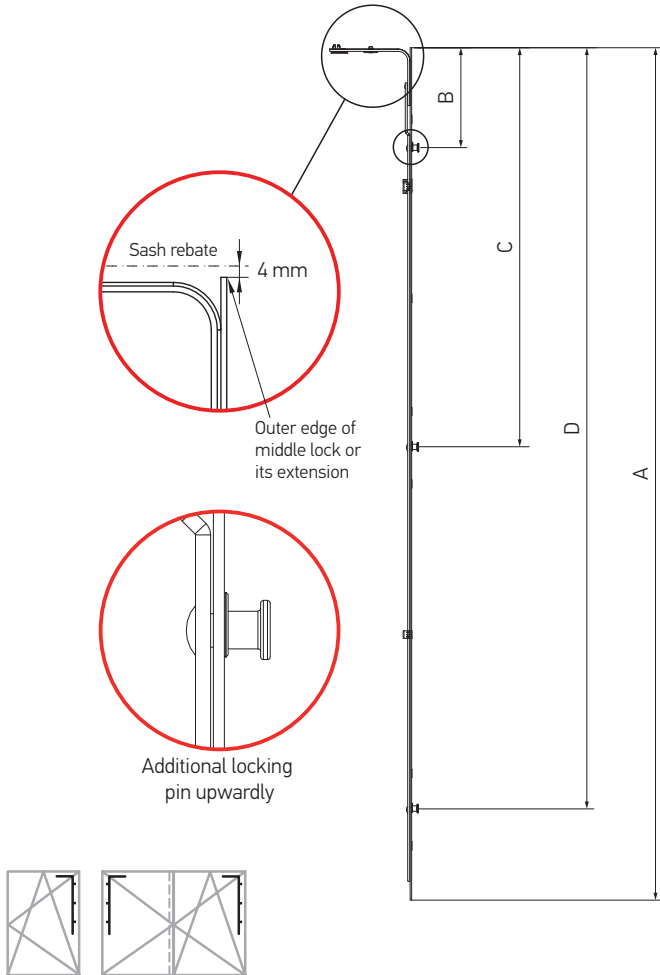

Middle lock extension, 1 MR, 680 mm

- for additional locking point;
- for height > 1710 mm.

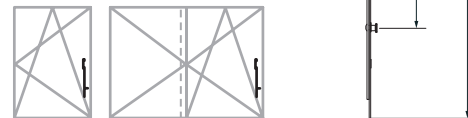

Description	SRH (mm)	SRW (mm)	Dimensions							Part No.
			A	B*	C*	D*				
Middle lock L=400, 2 MR	600-1000	600-1000	400	132	280	—	2	3	20	K4024-04-N03
Middle lock L=650, 2 MR	850-1250	850-1250	650	132	530	—	2	5	20	K4024-06-N03
Middle lock L=820, 2 MR	1251-1430	1251-1430	820	132	700	—	2	5	20	K4024-08-N03
Middle lock L=1130, 3 MR	1251-1730	—	1130	132	530	1010	3	8	20	K4024-11-N03
Description	SRH (mm)	SRW (mm)	Dimensions						Part No.	
			A	B	C					
Middle lock extension, 1 MR, 480 mm	1710-2210	1280-1520	480	360	—	1	4	20	K4025-05-N03	
Middle lock extension, 1 MR, 680 mm	2211-2390	—	680	560	—	1	5	20	K4025-07-N03	

* Dimensions B, C and D are distances from the outer edge of middle lock or its extension to the locking pin axis



Middle lock with additional mushroom pin

Corner transmissions
Middle locks

Middle lock ML with additional mushroom pin MR

Middle lock extension, 1 ML, 480 mm

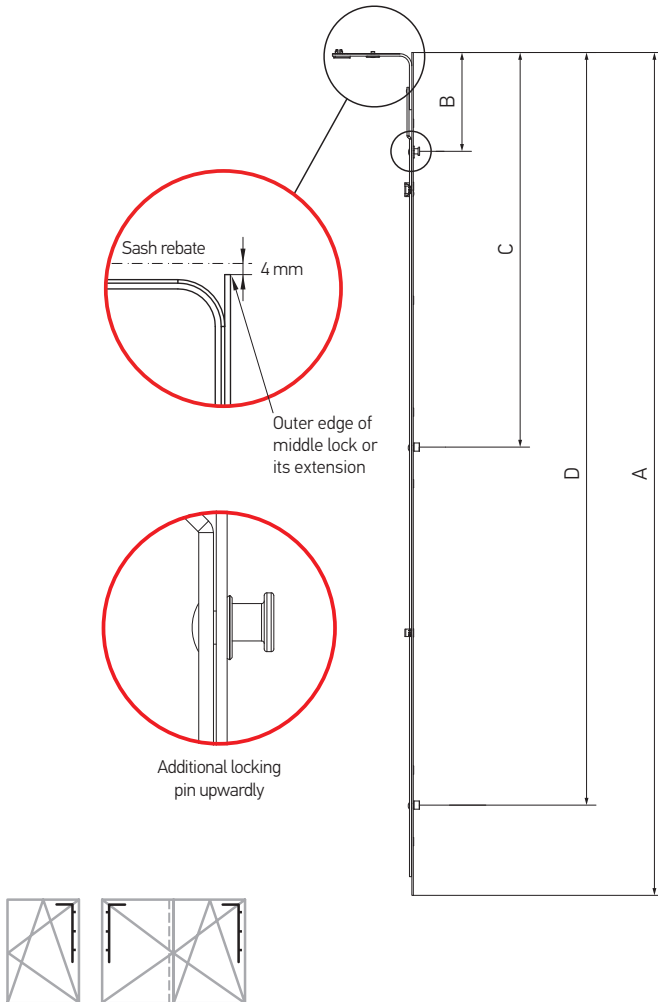

Middle lock extension, 1 ML, 680 mm

- for additional locking point;
- for height > 1710 mm.

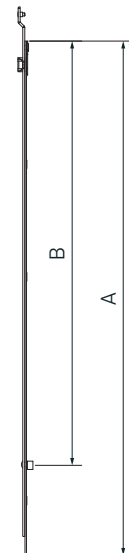
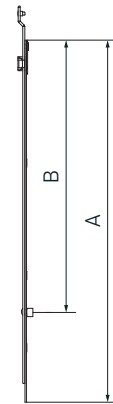

Description	SRH (mm)	SRW (mm)	Dimensions								Part No.
			A	B*	C*	D*					
Middle lock L=400, 1 MR + 1 ML, 600-1000	600-1000	600-1000	400	132	280	—	1	1	3	20	K4008-04-N03
Middle lock L=650, 1 MR + 1 ML, 850-1250	850-1250	850-1250	650	132	530	—	1	1	5	20	K4008-06-N03
Middle lock L=820, 1 MR + 1 ML, 1250-1430	1251-1430	1251-1430	820	132	700	—	1	1	5	20	K4008-08-N03
Middle lock L=1130, 1 MR + 2 ML, 1250-1730	1251-1730	—	1130	132	530	1010	2	1	8	20	K4008-11-N03
Description	SRH (mm)	SRW (mm)	Dimensions							Part No.	
			A	B	C						
Middle lock extension, 1 ML, 480 mm	1710-2210	1280-1520	480	360	—	1	0	4	20	K4005-05-N03	
Middle lock extension, 1 ML, 680 mm	2211-2390	—	680	560	—	1	0	5	20	K4005-07-N03	

* Dimensions B, C and D are distances from the outer edge of middle lock or its extension to the locking pin axis



Middle lock with additional FLAX pin

Corner transmissions
Middle locks

Middle lock ML with additional FLAX pin

Middle lock extension, 1FX, 480 mm

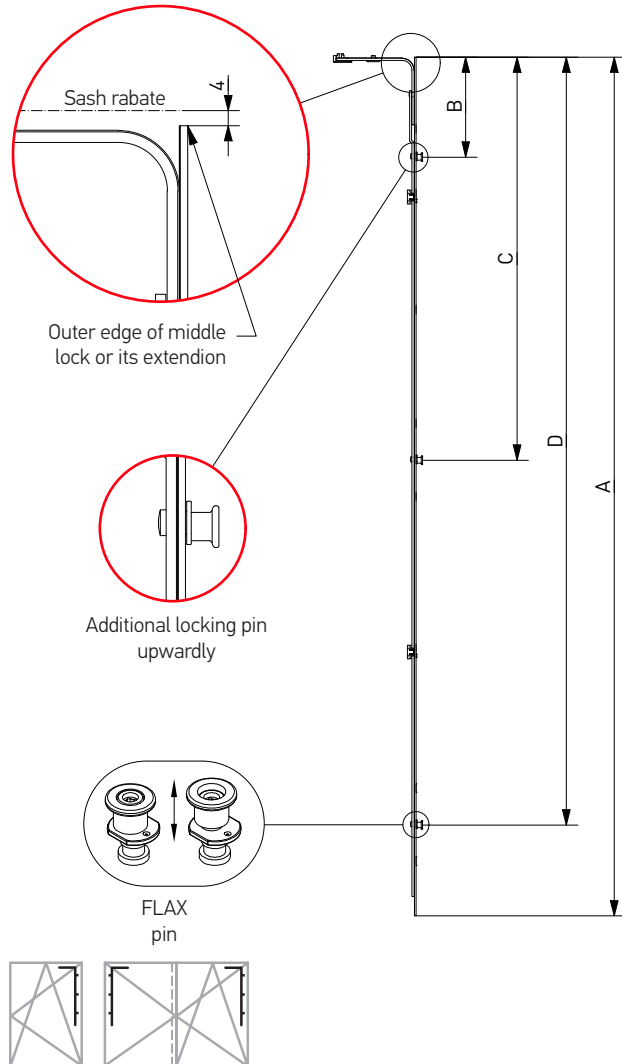

Middle lock extension, 1FX, 680 mm

- for additional locking point;
- for height > 1710 mm.

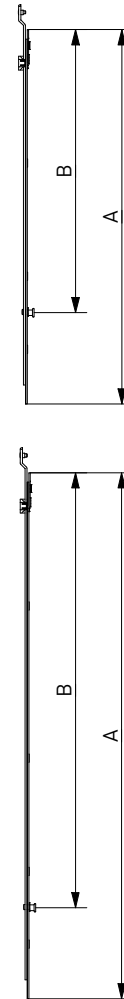

Description	SRH (mm)	SRW (mm)	Dimensions							Part No.
			A	B	C	D				
Middle lock L=400, 600-1000, 2FX	600-100	600-100	400	132	280	—	2	3	20	K4074-04-N03
Middle lock L=650, 850-1250, 2FX	850-1250	850-1250	650	132	530	—	2	5	20	K4074-06-N03
Middle lock L=820, 1251-1430, 2FX	1251-1430	1251-1430	820	132	700	—	2	5	20	K4074-08-N03
Middle lock L=1130, 1251-1730, 3FX	1251-1730	—	1130	132	530	1010	3	8	20	K4074-11-N03
Description	SRH (mm)	SRW (mm)	Dimensions						Part No.	
			A	B	C					
Middle lock extension 480 mm, 1711-2210, 1FX	1710-2210	1280-1520	480	360	—	1	4	20	K4075-05-N03	
Middle lock extension 680 mm, 2211-2390, 1FX	2211-2390	—	680	560	—	1	5	20	K4075-07-N03	



Extension locks

FOR STRAIGHT CUT





Extension locks

Corner transmissions
Middle locks

Extension lock 240 mm, 1 ML

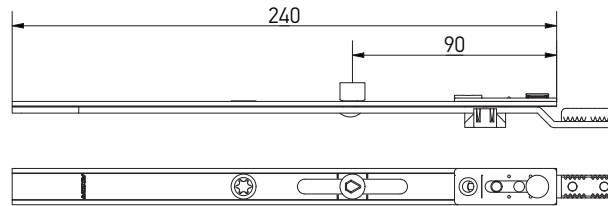

Extension lock 480 mm, 1 ML

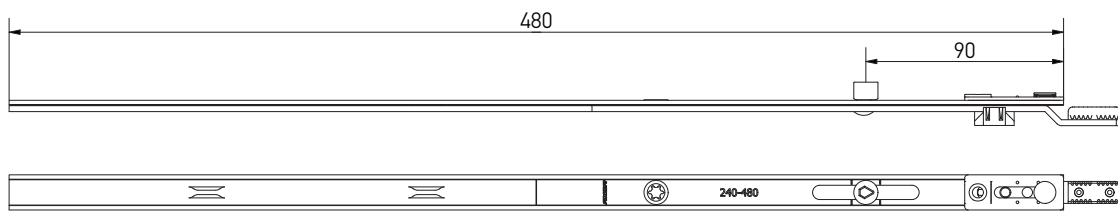

Extension lock 240 mm, 1 MR

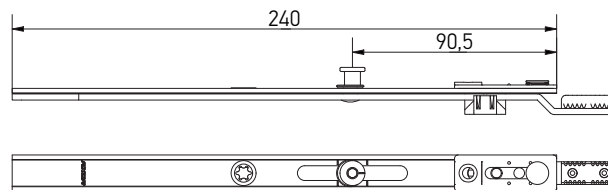

Extension lock 480 mm, 1 MR

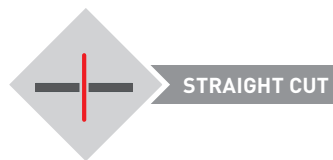
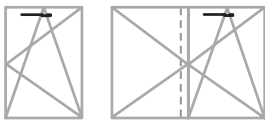
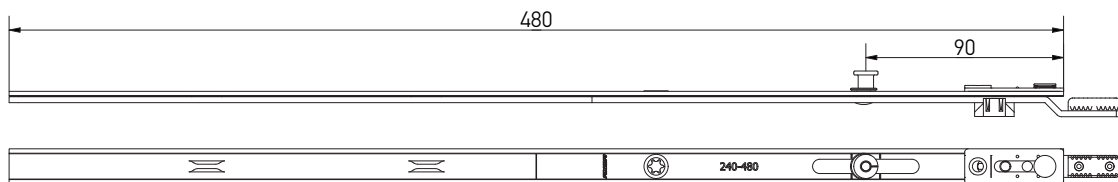

Description	Dimension					Part No.
Extension lock 240 mm, 1 ML	240	1	—	2	25	K4003-02-N03
Extension lock 480 mm, 1 ML	480	1	—	2	25	K4003-05-N03
Extension lock 240 mm, 1 MR	240	—	1	2	25	K4023-02-N03
Extension lock 480 mm, 1 MR	480	—	1	2	25	K4023-05-N03



Extension locks

Corner transmissions
Middle locks

Extension lock for corner transmission 480 mm, 1 ML

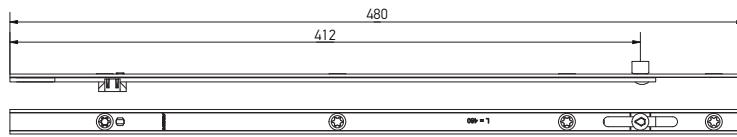

Extension lock for corner transmission 680 mm, 1 ML

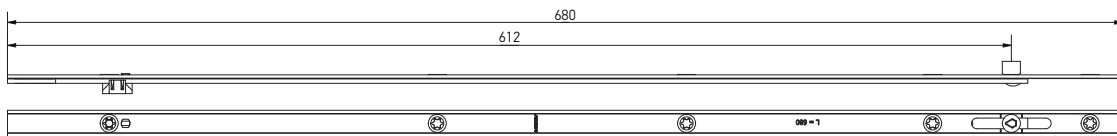

Extension lock for corner transmission 880 mm, 2 ML

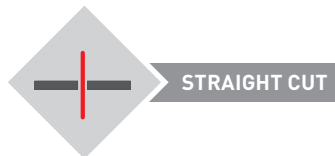
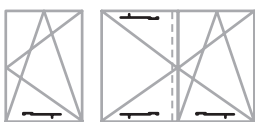
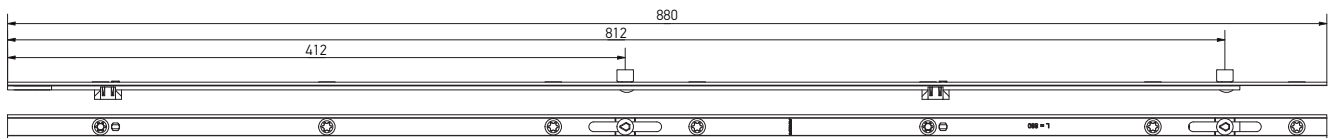

Description	Dimension				Part No.
Extension lock for corner transmission 480 mm, 1 ML	480	1	4	20	K4010-00-N03
Extension lock for corner transmission 680 mm, 1 ML	680	1	4	20	K4010-07-N03
Extension lock for corner transmission 880 mm, 2 ML	880	2	4	20	K4010-09-N03



Extension locks

Corner transmissions
Middle locks

Extension lock for corner transmission 480 mm, 1 MR

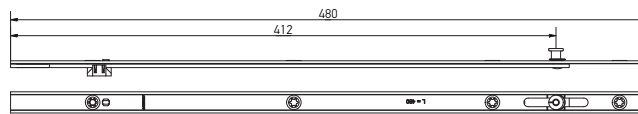

Extension lock for corner transmission 680 mm, 1 MR

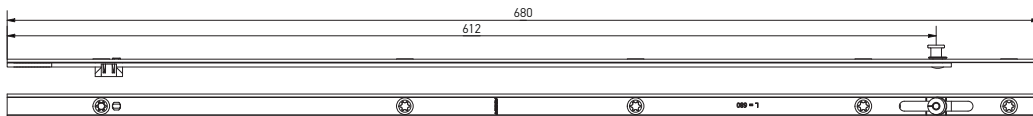

Extension lock for corner transmission 880 mm, 2 MR

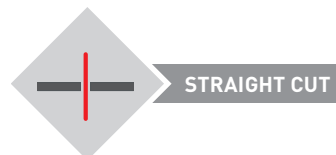
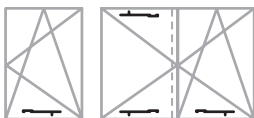
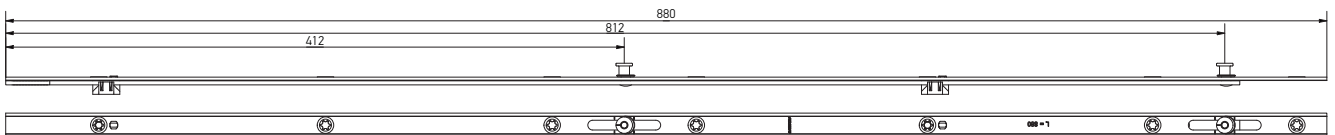

Description	Dimension				Part No.
Extension lock for corner transmission 480 mm, 1 MR	480	1	4	20	K4030-00-N03
Extension lock for corner transmission 680 mm, 1 MR	680	1	4	20	K4030-07-N03
Extension lock for corner transmission 880 mm, 2 MR	880	2	4	20	K4030-09-N03



Extension locks

Corner transmissions
Middle locks

Extension lock, double sash 240 mm

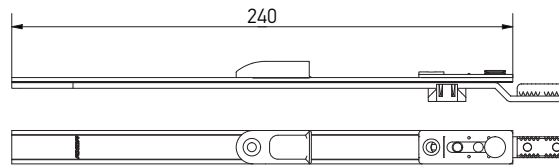

Extension lock, double sash 480 mm

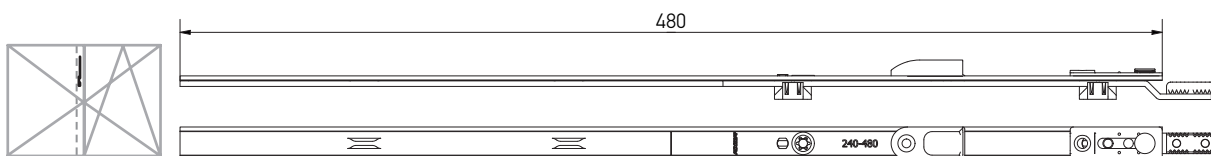

Extension lock 480 mm with possibility to cut, 1 MR

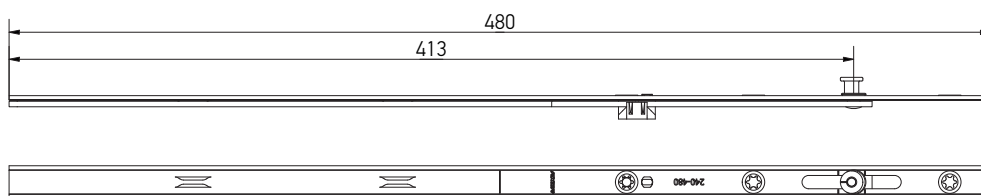

Extension lock 720 mm with possibility to cut, 1 MR

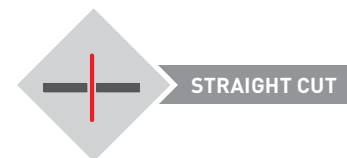
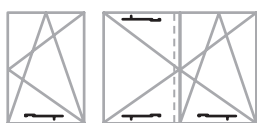
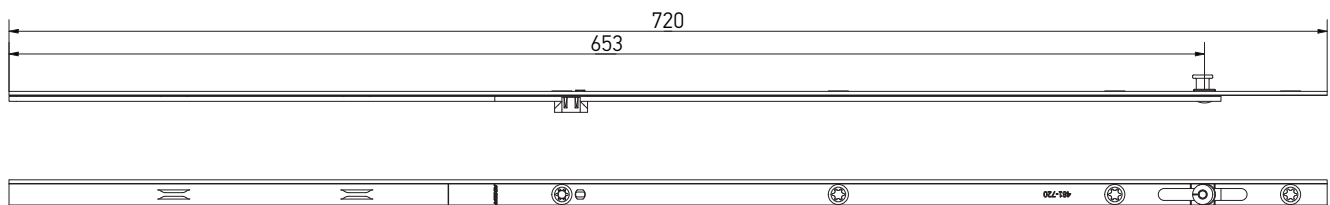

Description	Dimension				Part No.
Extension lock, double sash 240 mm	240	—	2	25	K4015-02-N03
Extension lock, double sash 480 mm	480	—	2	25	K4015-05-N03
Extension lock 480 mm with possibility to cut, 1 MR	480	1	3	20	K4036-05-N03
Extension lock 720 mm with possibility to cut, 1 MR	720	1	4	20	K4036-07-N03



Extension locks

Corner transmissions
Middle locks

Extension lock for aluminium doorstep

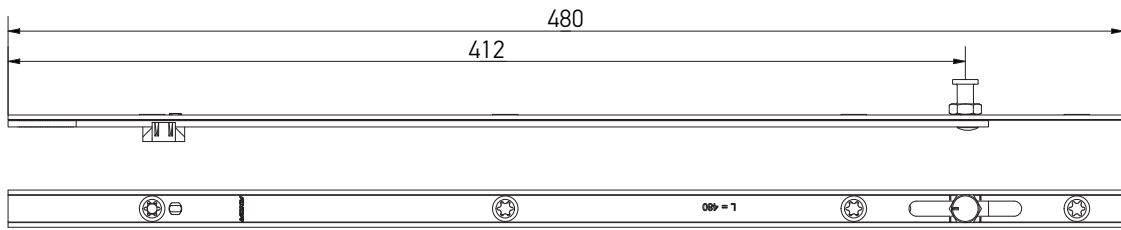

Extension lock 240 mm, without locking pin

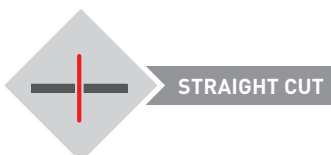
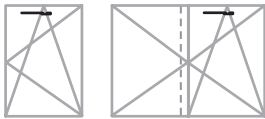
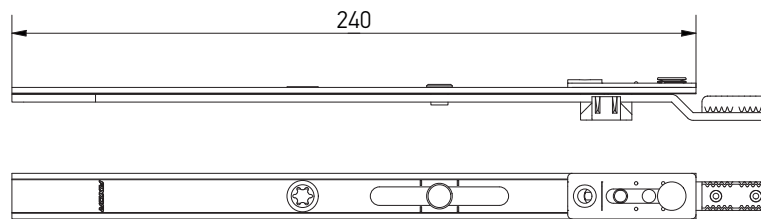

Description	Dimension					Part No.
Extension lock 480 mm, for aluminium doorstep, 1 MR	480	—	1	4	20	K4039-05-N03
Extension lock 240 mm, without locking pin	240	—	—	2	20	K4038-02-N03



Extension lock with sash lifter, ML

Corner transmissions
Middle locks

Extension lock L=480 mm, 1 ML, with sash lifter

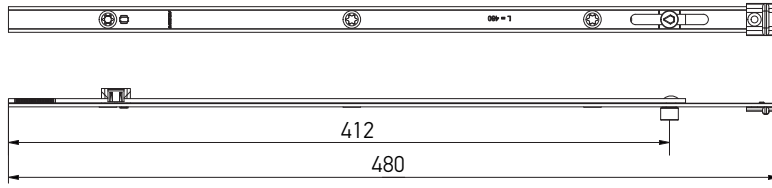

Extension lock L=680 mm, 1 ML, with sash lifter

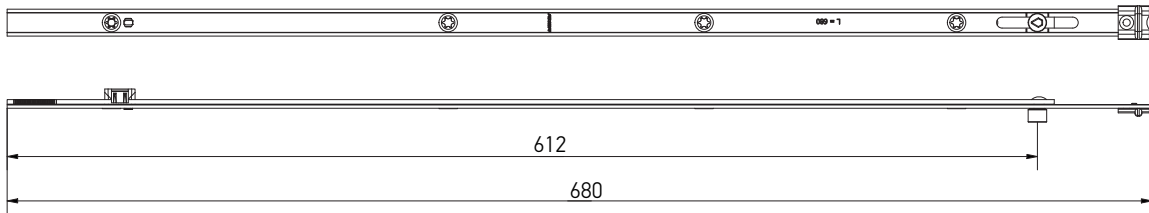

Extension lock L=880 mm, 2 ML, with sash lifter

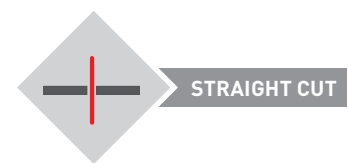
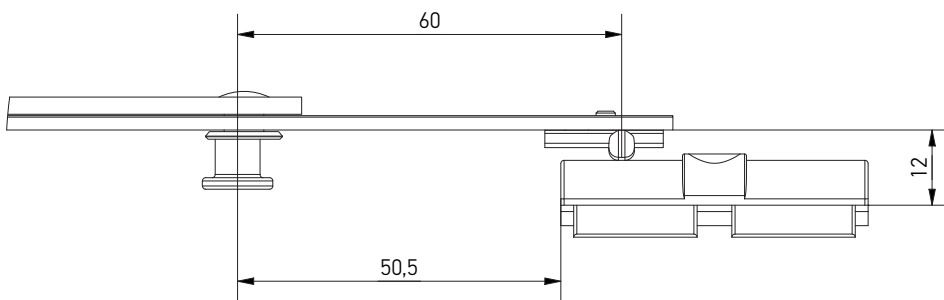
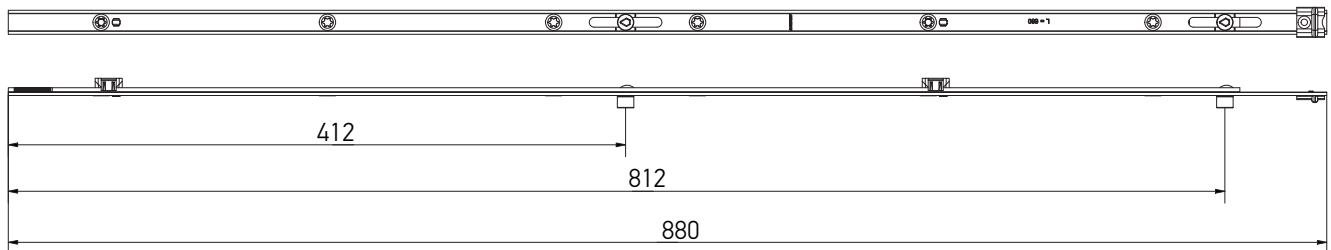

The extension locks K4062-XX-N03, K4063-XX-N03, K4066-XX-N03, K4067-XX-N03 use together with the suitable frame part A7237-XX-N03.

The suitable frame part (A7237-XX-N03) can be found on p. 223.

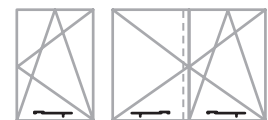

Description	Dimension				Part No.
Extension lock L=480 mm, 1 ML, with sash lifter	480	1	4	20	K4062-05-N03
Extension lock L=680 mm, 1 ML, with sash lifter	680	1	5	20	K4062-07-N03
Extension lock L=880 mm, 2 ML, with sash lifter	880	2	7	20	K4062-09-N03
Frame part of sash lifter	Look at the section "Profile-dependent elements"				



Extension lock with sash lifter, MR

Corner transmissions
Middle locks

Extension lock L=480 mm, 1 MR, with sash lifter

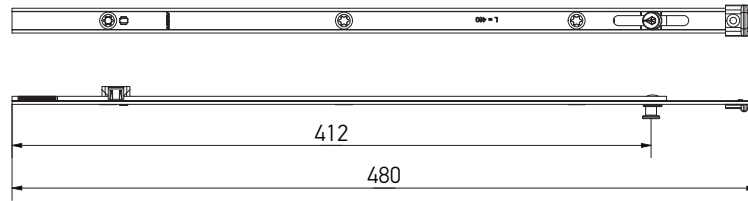

Extension lock L=680 mm, 1 MR, with sash lifter

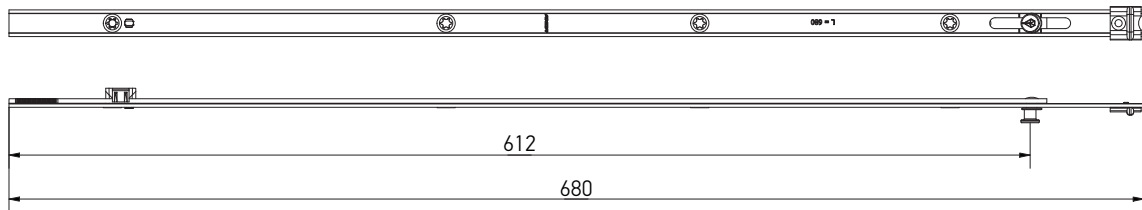

Extension lock L=880 mm, 2 MR, with sash lifter

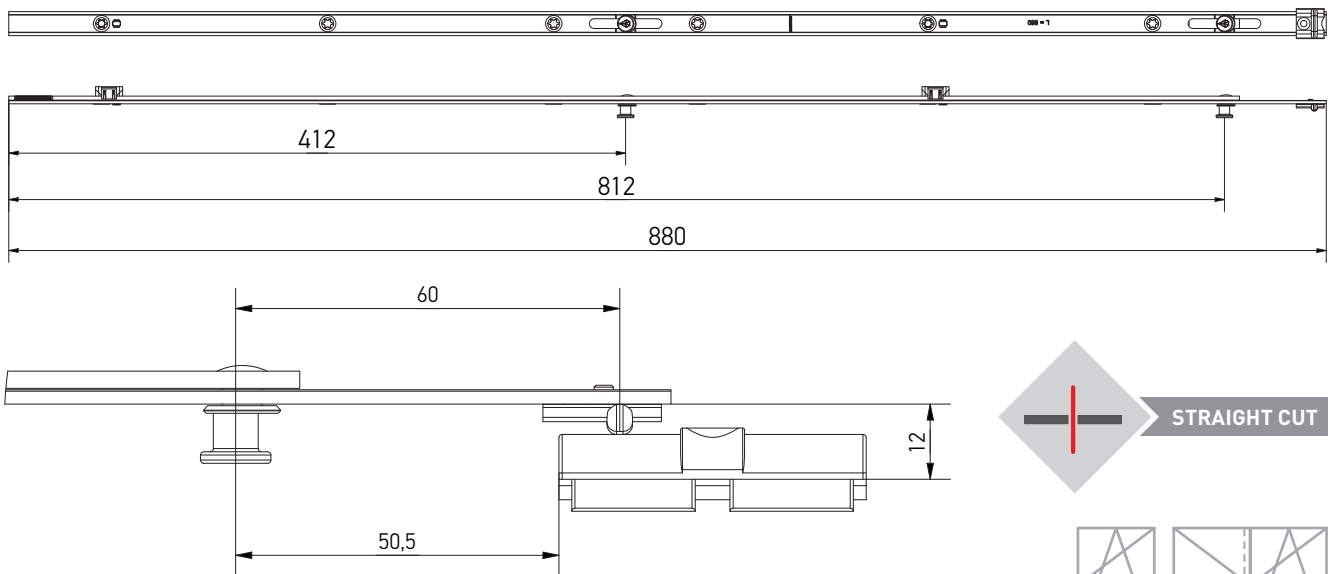

The extension locks K4062-XX-N03, K4063-XX-N03, K4066-XX-N03, K4067-XX-N03 use together with the suitable frame part A7237-XX-N03.

The suitable frame part (A7237-XX-N03) can be found on p. 223.

Description	Dimension				Part No.
Extension lock L=480 mm, 1 MR, with sash lifter	480	1	4	20	K4063-05-N03
Extension lock L=680 mm, 1 MR, with sash lifter	680	1	5	20	K4063-07-N03
Extension lock L=880 mm, 2 MR, with sash lifter	880	2	7	20	K4063-09-N03
Frame part of sash lifter	Look at the section "Profile-dependent elements"				

Extension lock template

Look at the section "Installation tools"

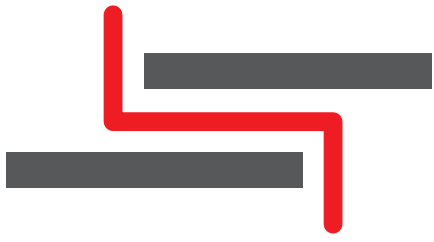

Extension locks

FOR ECCENTRIC CUT

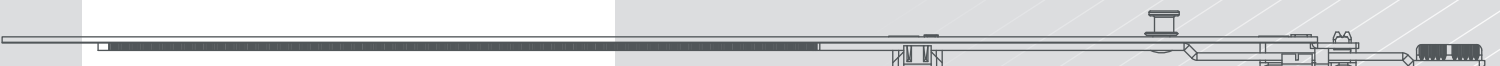

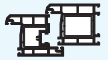

Extension locks

Corner transmissions
Middle locks

Extension lock 240 mm, 1 ML

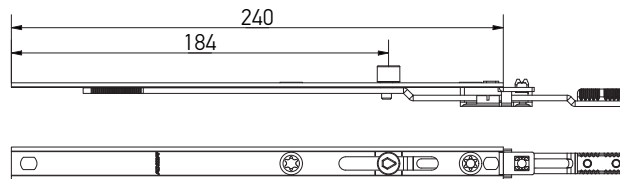

Extension lock 480 mm, 1 ML

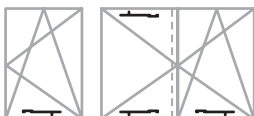
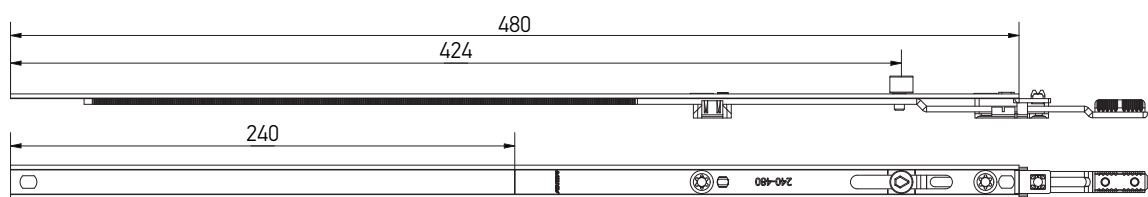

Description	Dimension				Part No.
Extension lock 240 mm, 1 ML	240	1	2	25	K4056-02-N03
Extension lock 480 mm, 1 ML	480	1	2	25	K4056-05-N03



Extension locks

Corner transmissions
Middle locks

Extension lock for corner transmission 480 mm, 1 ML

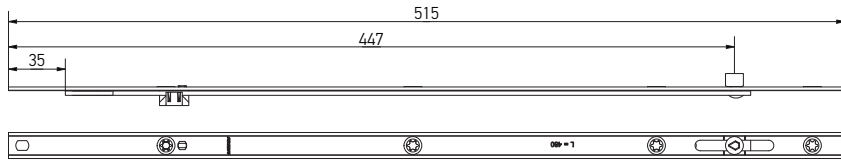

Extension lock for corner transmission 680 mm, 1 ML

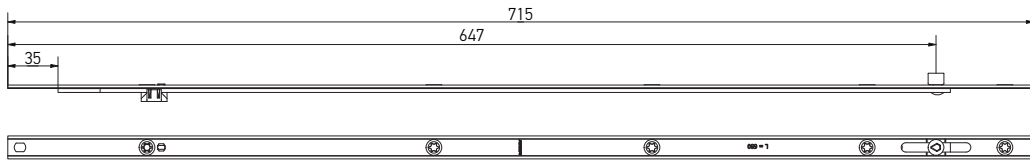

Extension lock for corner transmission 880 mm, 2 ML

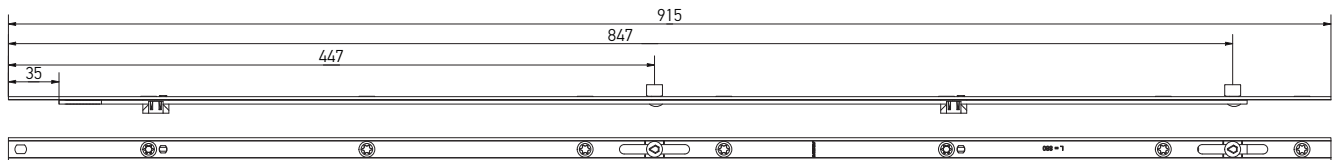

ECCENTRIC CUT

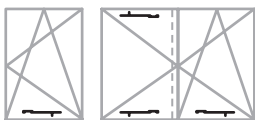

Description	Dimension				Part No.
Extension lock for corner transmission 480 mm, 1 ML	515	1	4	20	K4053-05-N03
Extension lock for corner transmission 680 mm, 1 ML	715	1	4	20	K4053-07-N03
Extension lock for corner transmission 880 mm, 2 ML	915	2	4	20	K4053-09-N03



Extension locks

Corner transmissions
Middle locks

Extension lock for corner transmission 480 mm, 1 MR

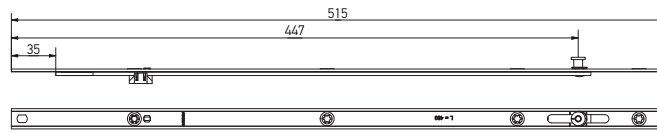

Extension lock for corner transmission 680 mm, 1 MR

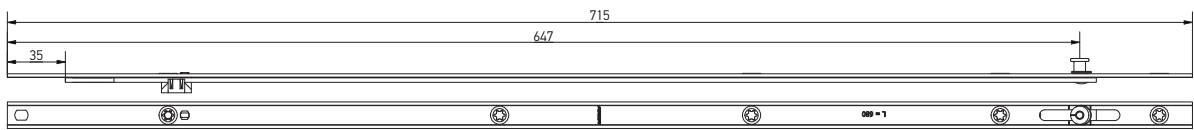

Extension lock for corner transmission 880 mm, 2 MR

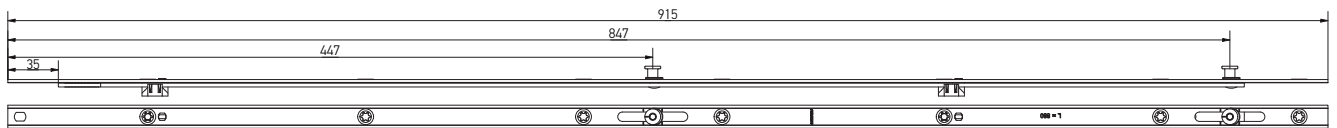

ECCENTRIC CUT

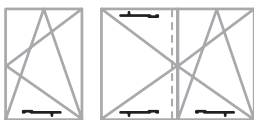

Description	Dimension				Part No.
Extension lock for corner transmission 480 mm, 1 MR	515	1	4	20	K4054-05-N03
Extension lock for corner transmission 680 mm, 1 MR	715	1	4	20	K4054-07-N03
Extension lock for corner transmission 880 mm, 2 MR	915	2	4	20	K4054-09-N03



Extension locks

Corner transmissions
Middle locks

Extension lock, double sash 240 mm

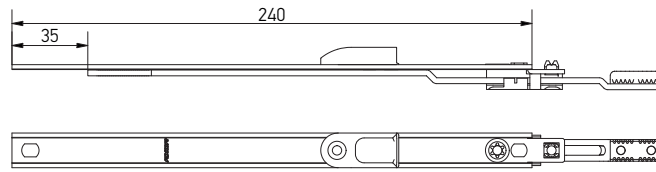

Extension lock, double sash 480 mm

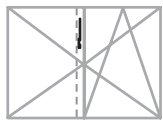
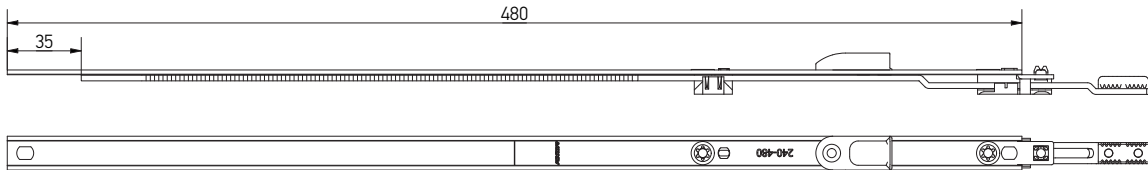

Extension lock with possibility to cut, 1 MR

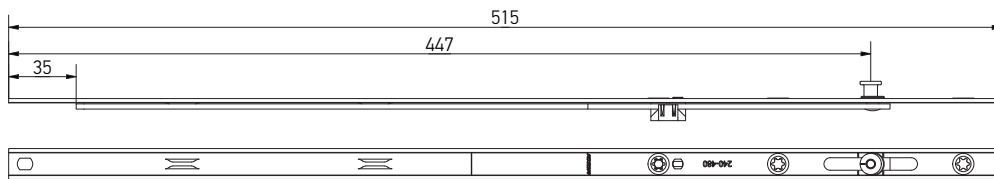

Extension lock with possibility to cut, 1 MR

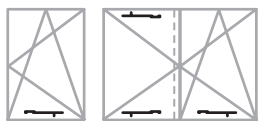
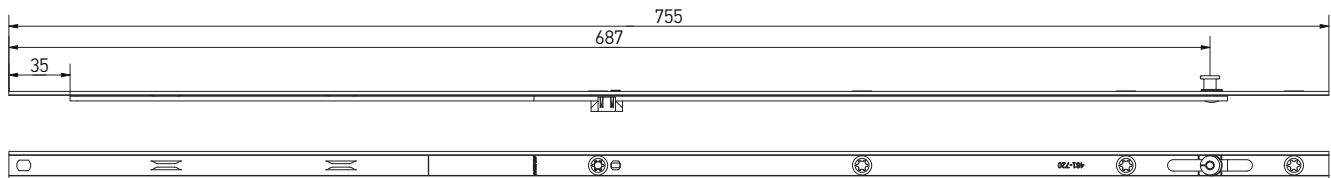

Description	Dimension					Part No.
Extension lock, double sash 240 mm	240	—	—	1	25	K4055-02-N03
Extension lock, double sash 480 mm	480	—	—	2	25	K4055-05-N03
Extension lock 480 mm with possibility to cut, 1 MR	515	—	1	3	20	K4058-05-N03
Extension lock 720 mm with possibility to cut, 1 MR	755	—	1	4	20	K4058-07-N03

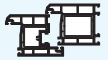

Extension lock for aluminium doorstep

Corner transmissions
Middle locks

Extension lock for aluminium doorstep

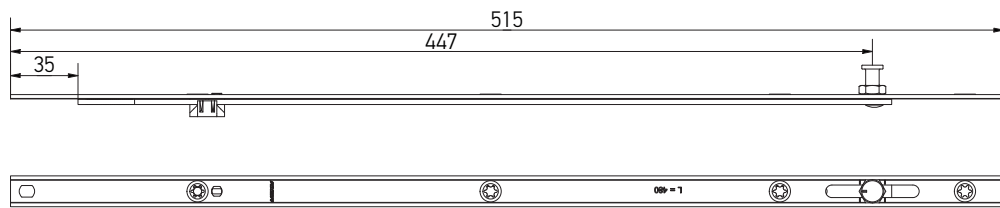

Extension lock, without locking pin

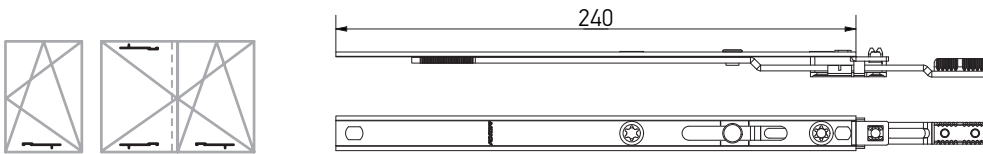

Description	Dimension					Part No.
Extension lock 480 mm, for aluminium doorstep, 1 MR	515	—	1	4	20	K4059-05-N03
Extension lock 240 mm, without locking pin	240	—	—	2	25	K4057-02-N03



Extension locks



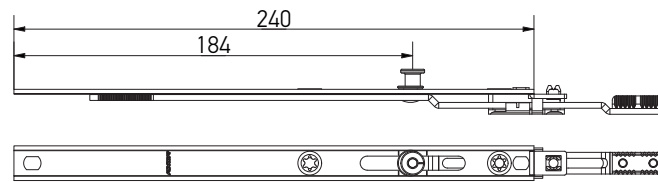

Corner transmissions
Middle locks

Extension lock 240 mm, 1 MR

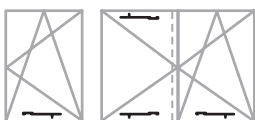
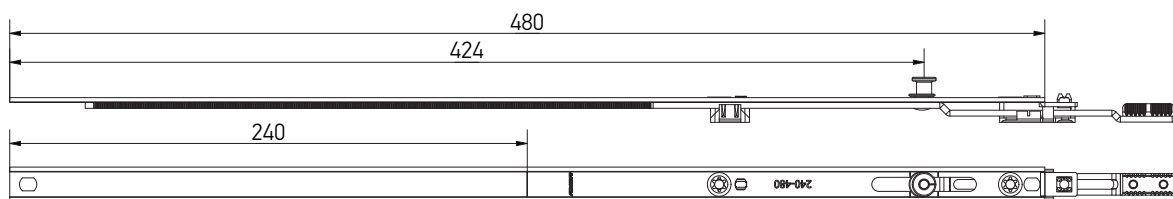

Extension lock 480 mm, 1 MR



Description	Dimension					Part No.
Extension lock 240 mm, 1 MR	240	—	1	2	25	K4050-02-N03
Extension lock 480 mm, 1 MR	480	—	1	2	25	K4050-05-N03



Extension lock with sash lifter, ML

Corner transmissions
Middle locks

Extension lock L = 480 mm, 1 ML, with sash lifter

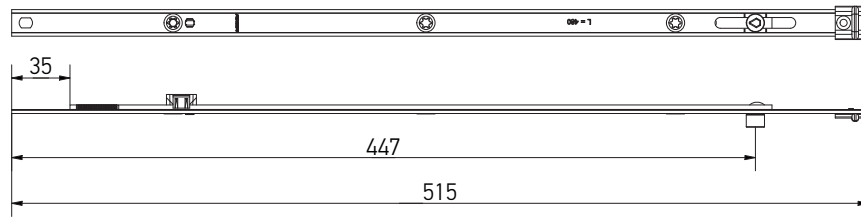

Extension lock L = 680 mm, 1 ML, with sash lifter

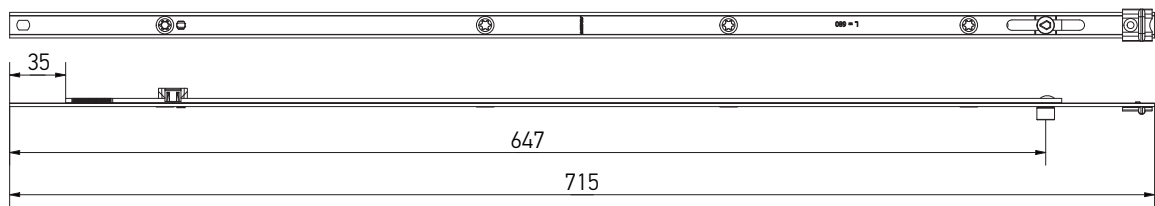

Extension lock L = 880 mm, 2 ML, with sash lifter

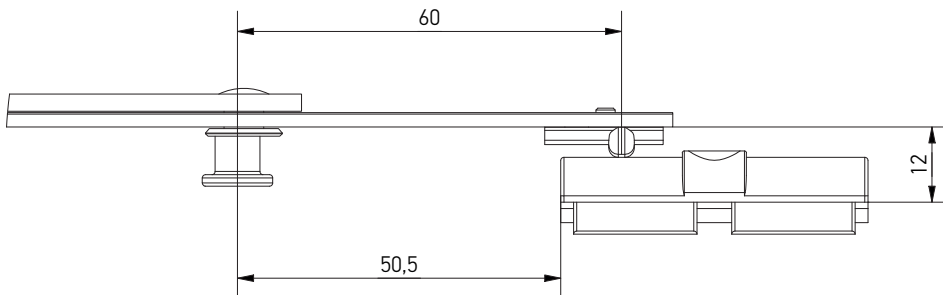
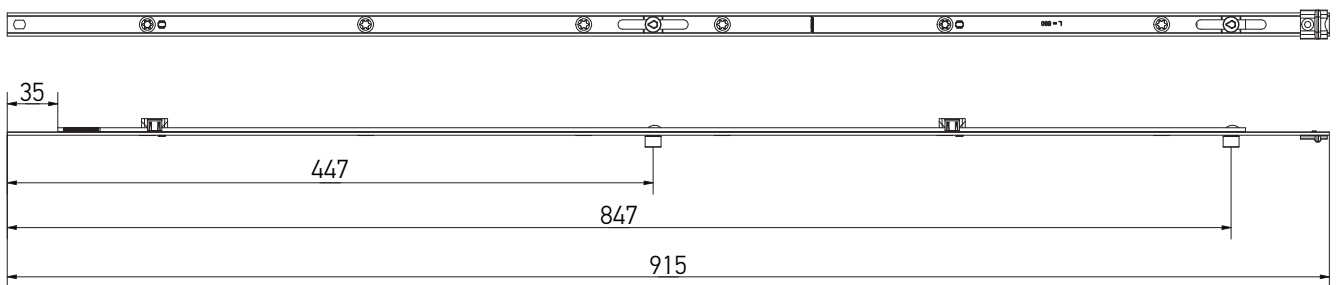

The extension locks K4062-XX-N03, K4063-XX-N03, K4066-XX-N03, K4067-XX-N03 use together with the suitable frame part A7237-XX-N03.

The suitable frame part [A7237-XX-N03] can be found on p. 223.

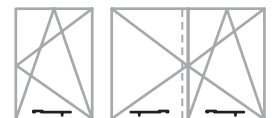

Description	Dimension				Part No.
Extension lock L = 480 mm, 1 ML, with sash lifter	515	1	5	20	K4066-05-N03
Extension lock L = 680 mm, 1 ML, with sash lifter	715	1	6	20	K4066-07-N03
Extension lock L = 880 mm, 2 ML, with sash lifter	915	2	8	20	K4066-09-N03
Frame part of sash lifter	Look at the section "Profile-dependent elements"				



Extension lock with sash lifter, MR

Corner transmissions
Middle locks

Extension lock L = 480 mm, 1 MR, with sash lifter

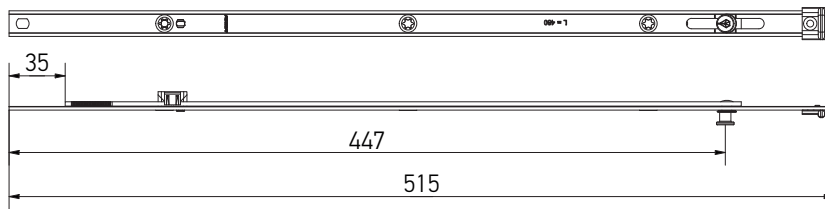

Extension lock L = 680 mm, 1 MR, with sash lifter

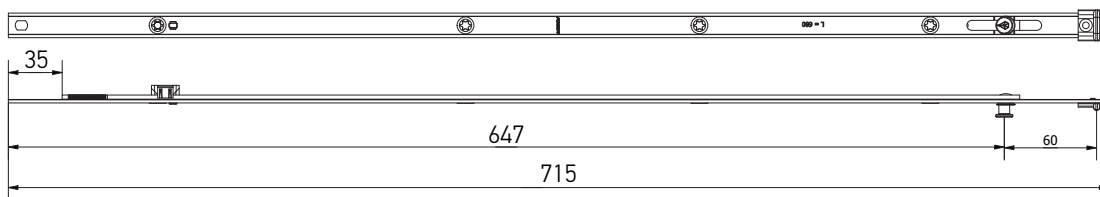

Extension lock L = 880 mm, 2 MR, with sash lifter

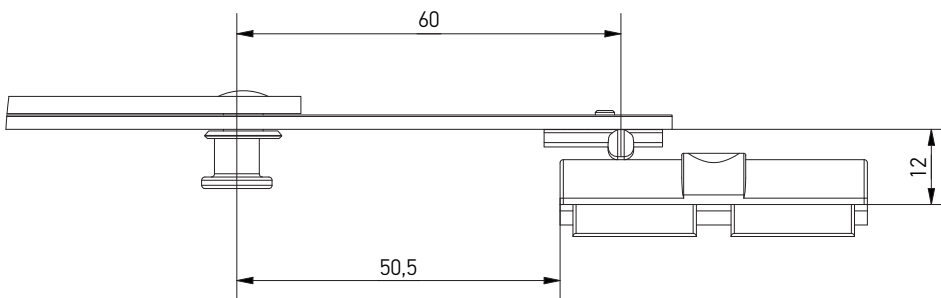
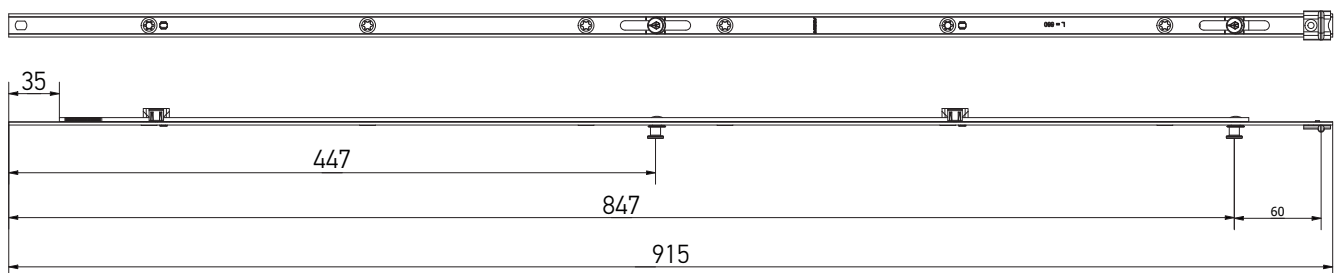

The extension locks K4062-XX-N03, K4063-XX-N03, K4066-XX-N03, K4067-XX-N03 use together with the suitable frame part A7237-XX-N03.

The suitable frame part (A7237-XX-N03) can be found on p. 223.

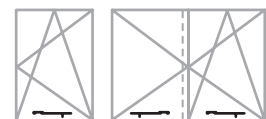

Description	Dimension				Part No.
Extension lock L = 480 mm, 1 MR, with sash lifter	515	1	5	20	K4067-05-N03
Extension lock L = 680 mm, 1 MR, with sash lifter	715	1	6	20	K4067-07-N03
Extension lock L = 880 mm, 2 MR, with sash lifter	915	2	8	20	K4067-09-N03
Frame part of sash lifter	Look at the section "Profile-dependent elements"				

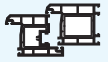



Extension lock, FLAX pin

Corner transmissions
Middle locks

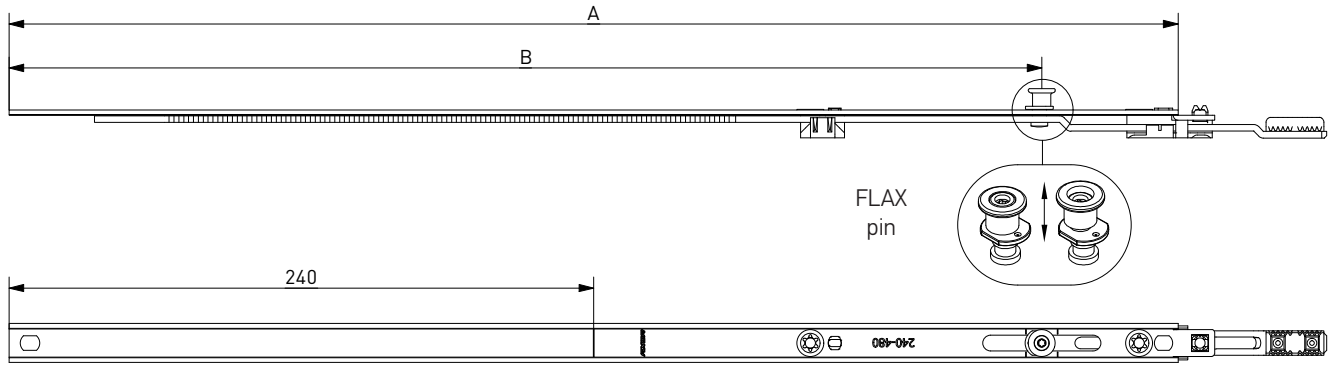
Extension lock, FLAX pin



Description	Dimension					Part No.
	A	B				
Extension lock 130 mm, 1FX (eccentric cut)	130	74	1	1	25	K4076-00-N03
Extension lock 180 mm, 1FX (eccentric cut)	180	124	1	2	25	K4076-01-N03
Extension lock 240 mm, 1FX (eccentric cut)	240	184	1	2	25	K4076-02-N03
Extension lock 480 mm, 1FX (eccentric cut)	480	424	1	2	25	K4076-05-N03



Extension lock FLAX pin

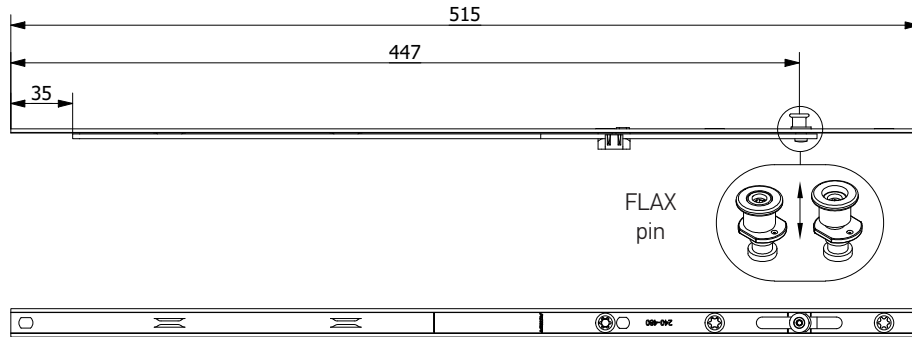

Corner transmissions
Middle locks

Extension lock 515 mm with possibility to cut, 1FX

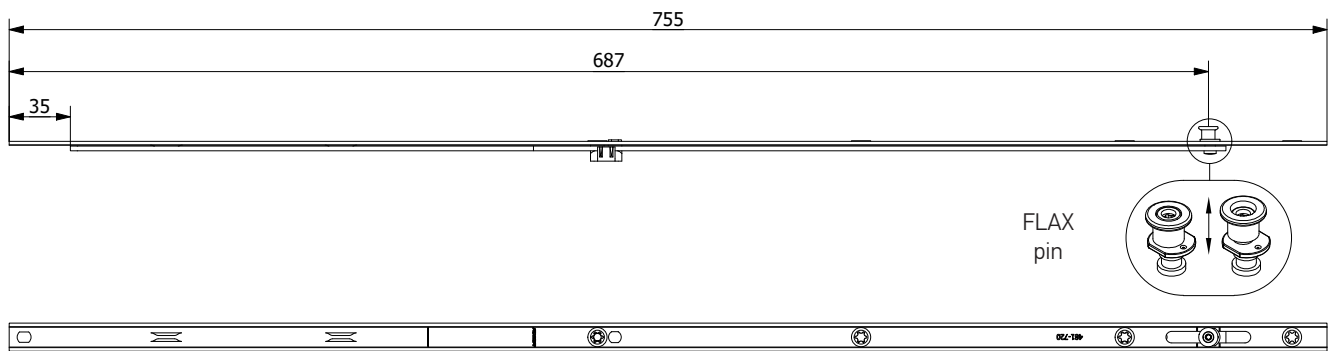

Extension lock 755 mm with possibility to cut, 1FX



Description	Dimension				Part No.
Extension lock 515 mm with possibility to cut, 1FX	515	1	3	20	K4077-05-N03
Extension lock 755 mm with possibility to cut, 1FX	755	1	4	20	K4077-07-N03



Extension lock with sash lifter FLAX pin

Corner transmissions
Middle locks

Extension lock with sash lifter FLAX pin

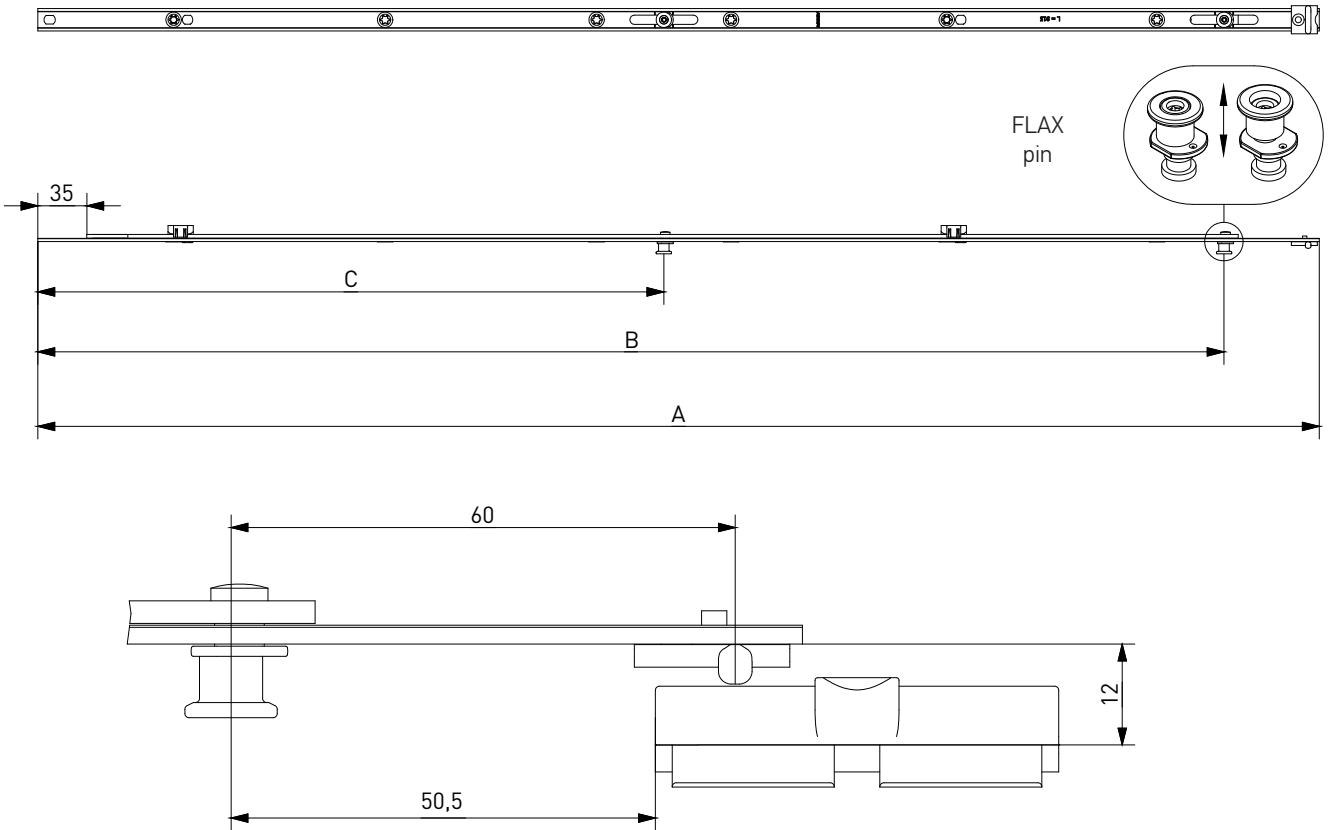

Description	Dimension						Part No.
	A	B	C				
Extension lock, L=275 mm, with sash lifter, 1FX	275	207	—	1	2	20	K4078-02-N03
Extension lock, L=515 mm, with sash lifter, 1FX	515	447	—	1	3	20	K4078-05-N03
Extension lock, L=715 mm, with sash lifter, 1FX	715	647	—	1	4	20	K4078-07-N03
Extension lock, L=915 mm, with sash lifter, 2FX	915	847	447	2	5	20	K4078-09-N03



Middle connection

Corner transmissions
Middle locks

Middle connection

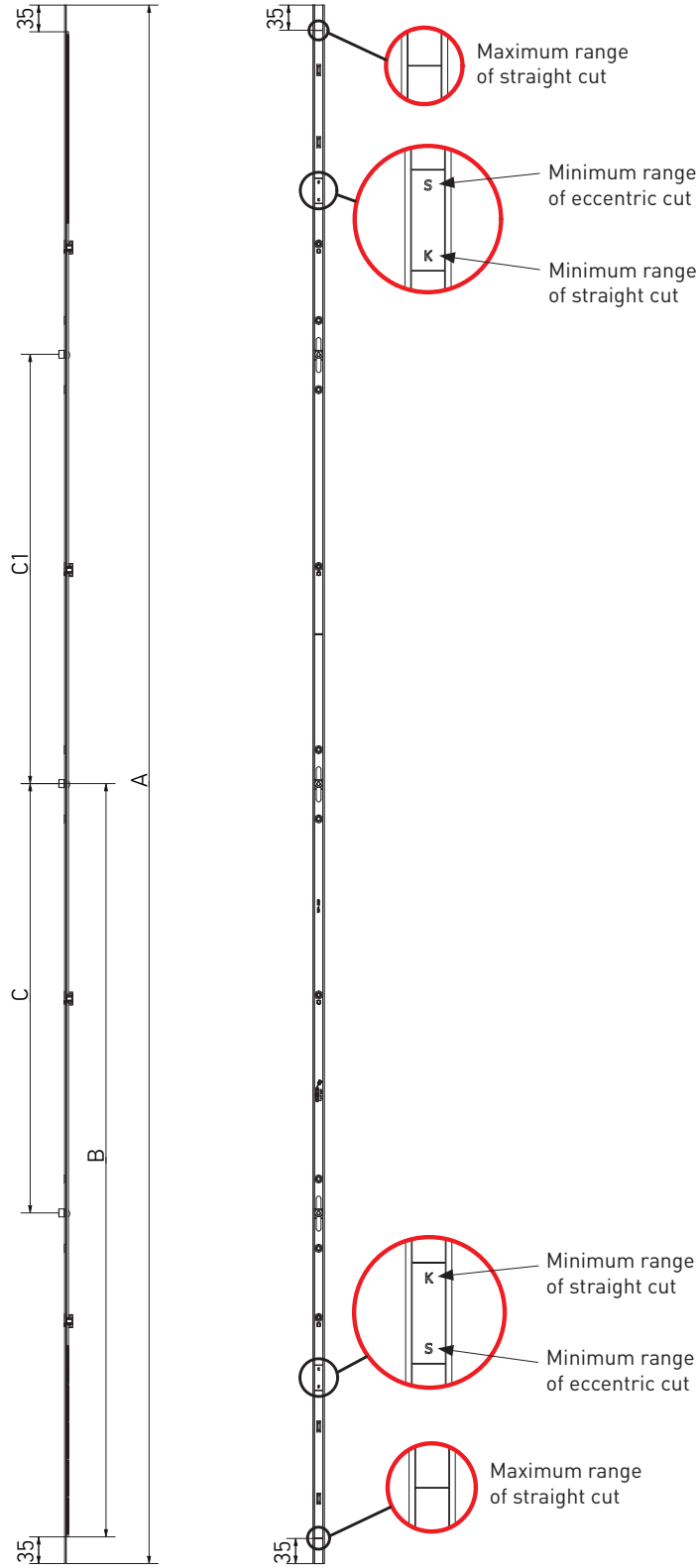



Middle connection

Corner transmissions
Middle locks

Description	SRW (mm)	Dimensions								Part No.
		A	B	C	C-1					
Middle connection L = 520, 551-750	551-750	520	225	—	—	—	—	2	20	K4013-05-N03
Middle connection L = 720, 751-950, 1 ML	751-950	720	325	—	—	1	—	4	20	K4013-07-N03
Middle connection L = 1200, 951-1430, 1 ML	951-1430	1200	565	—	—	1	—	4	20	K4013-11-N03
Middle connection L = 1680, 1431-1910, 2 ML	1431-1910	1680	805	330	330	2	—	8	10	K4013-16-N03
Middle connection L = 2160, 1911-2390, 3 ML	1911-2390	2160	1045	595	595	3	—	10	10	K4013-21-N03
Middle connection* L = 720, 751-950, 1 MR	751-950	720	325	—	—	—	1	4	20	K4033-07-N03
Middle connection* L = 1200, 951-1430, 1 MR	951-1430	1200	565	—	—	—	1	4	20	K4033-11-N03
Middle connection* L = 1680, 1431-1910, 2 MR	1431-1910	1680	805	330	330	—	2	8	10	K4033-16-N03
Middle connection* L = 2160, 1911-2390, 3 MR	1911-2390	2160	1045	595	595	—	3	10	10	K4033-21-N03

* we offer security pins for different degree of protection



Bottom extension

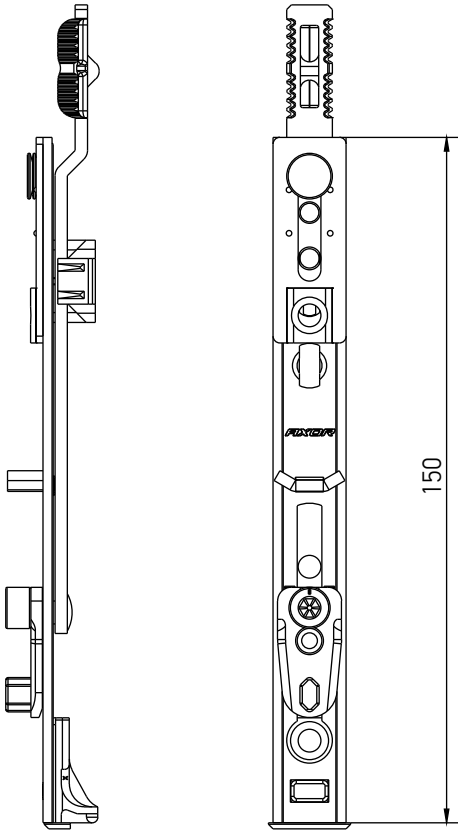

Corner transmissions
Middle locks

Bottom extension

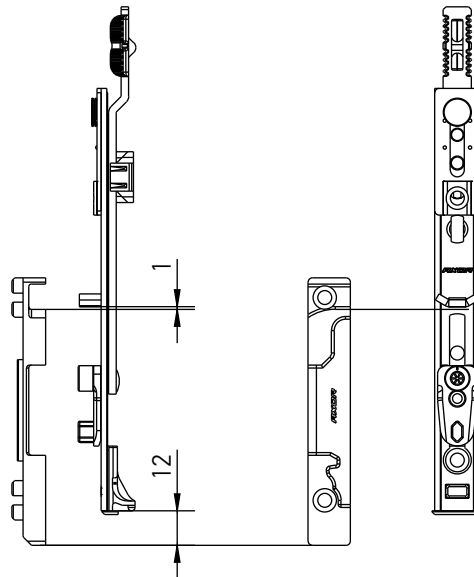

- not intended for RC security level;
- connection of middle lock is available.



Description	SRH (mm)			Part No.
Bottom extension	450-800	3	50	K4009-00-N03
Bottom extension	801-2390	3	50	K4002-00-N03



Shoot bolt

Corner transmissions
Middle locks

Shoot bolt

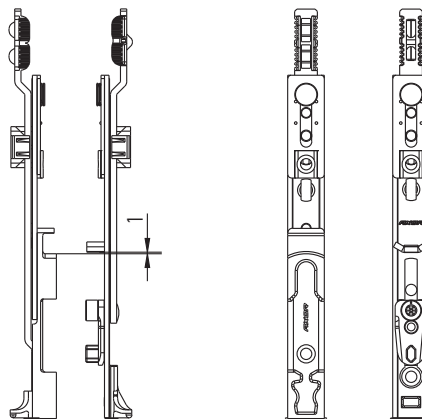
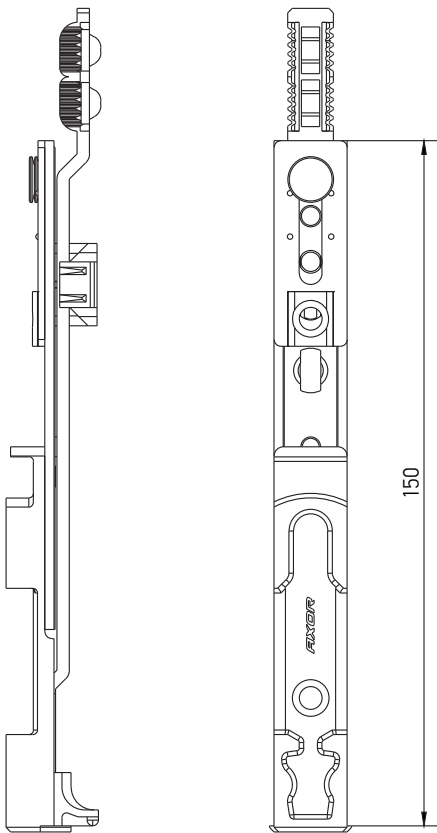

- latch outlet 11 mm;
- use with K1002-XX-N03 gear;
- not destined for safety level;
- connection of middle lock is available.

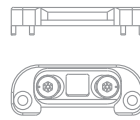
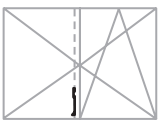

Description	SRW (mm)	SRH (mm)			Part No.
Shoot bolt (bottom)	400-1280	551-2390	3	50	K4006-00-N03

Description	Profile	Side opening	A	C	B			Part No.
Locking plate adjustable for shoot bolt	Rehau (13 mm), Aluplast, WDS, Veka	L/R	12	20	13	2	100	K6002-13-N03
Locking plate adjustable for shoot bolt	KBE (9 mm)	L/R	12	20	9	2	100	K6002-09-N03

A - sash rebate gap / C - sash overlap / B - sash groove position



Shoot bolt

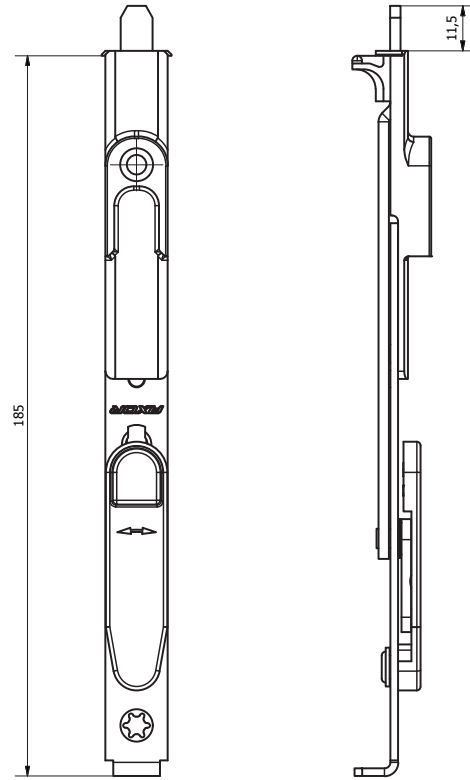
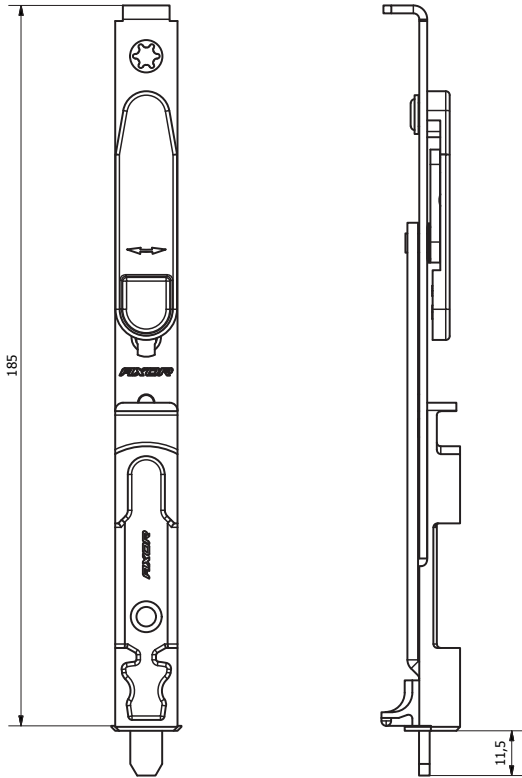

Shoot bolt, bottom

Shoot bolt, top

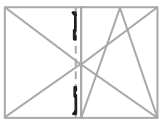

- latch outlet 11,5 mm;
- not destined for safety level;
- connection of middle lock is available.



Description	SRW (mm)	SRH (mm)			Part No.
Shoot bolt (bottom)	400-1280	551-2390	3	50	K4035-01-N03
Shoot bolt (top)	400-1280	551-2390	3	50	K4035-02-N03



Bottom extension for turn sash

Corner transmissions
Middle locks

Bottom extension for turn sash 180° (top), 1 ML

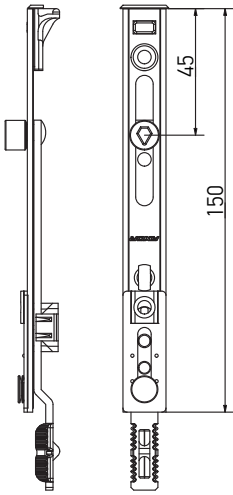

- connection of middle lock is available.

Bottom extension for turn sash 180° (top), 1 MR

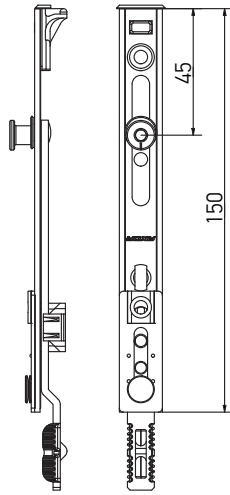

- connection of middle lock is available.

Bottom extension for turn sash 90° (top), 1 ML

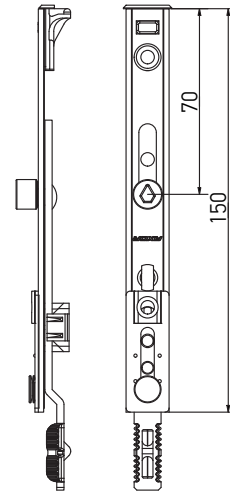

- connection of middle lock is available.

Bottom extension for turn sash 90° (bottom), 1 ML

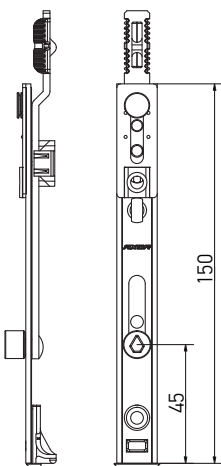

- connection of middle lock is available.

Bottom extension for turn sash 90° (bottom), 1 MR

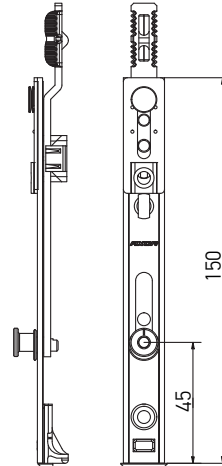

- connection of middle lock is available.

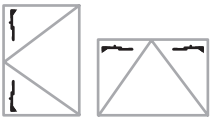

Description	SRH (mm)					Part No.
Bottom extension for turn sash 180° (top), 1 ML	450-2390	1	—	3	50	K4011-00-N03
Bottom extension for turn sash 90° (bottom), 1 ML	450-2390	1	—	3	50	K4007-00-N03
Bottom extension for turn sash 180° (top), 1 MR	450-2390	—	1	3	50	K4031-00-N03
Bottom extension for turn sash 90° (bottom), 1 MR	450-2390	—	1	3	50	K4027-00-N03
Bottom extension for turn sash 90° (top), 1 ML	450-2390	1	—	3	50	K4037-00-N03

AXORTM

KOMFORT LINE K-3

Stay arms

AXOR



Stay arm

Stay arm

Stay arm

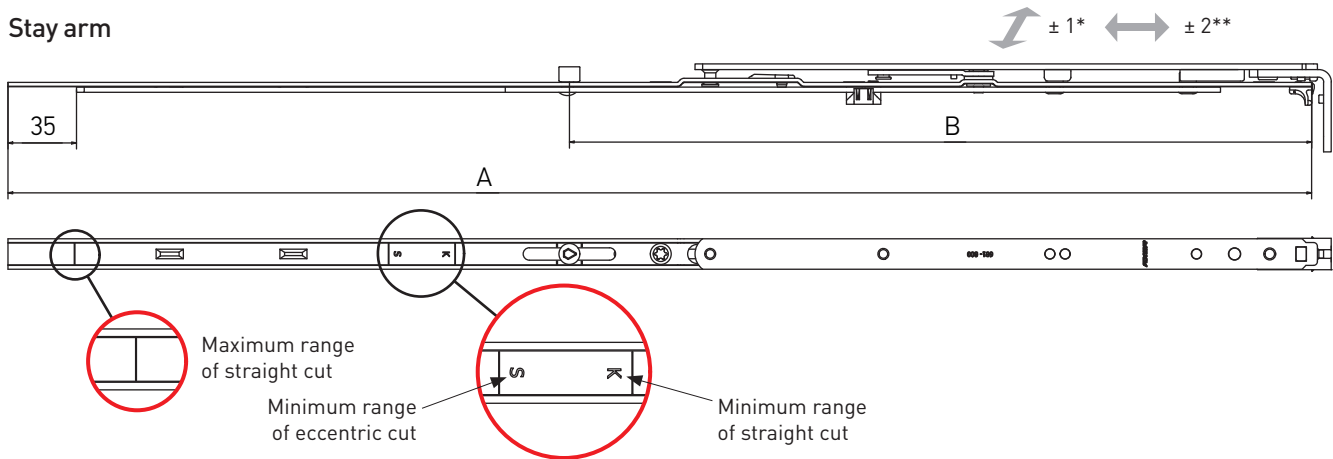

Stay arm, 1 MR

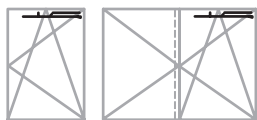
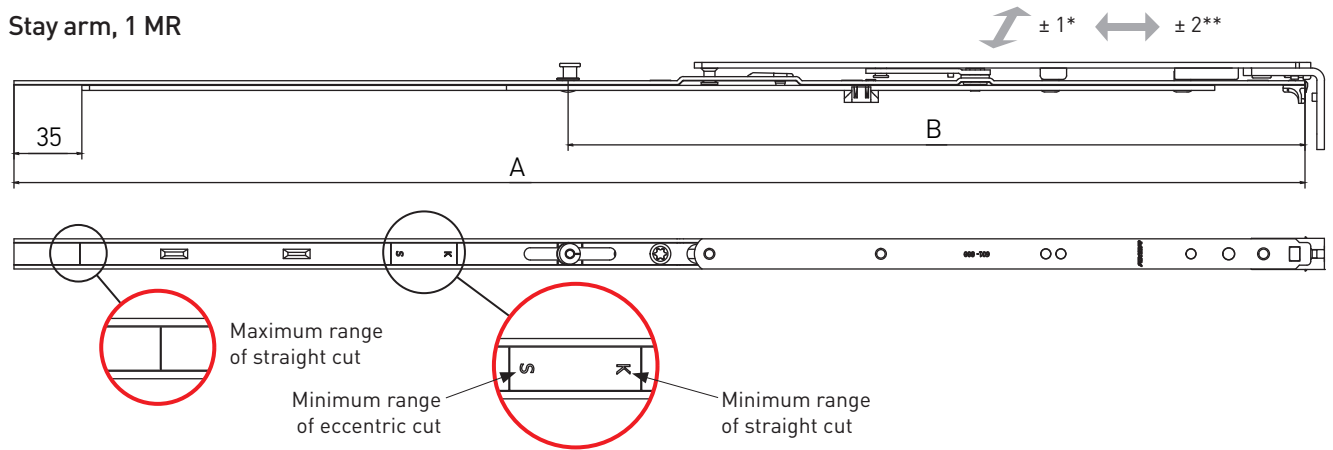

- for 18-22 mm sash overlap;
- sash rebate gap min. 12 mm.

* clamp adjustment, mm
** horizontal adjustment, mm

Description	SRW (mm)	Dimensions							Part No.
		A	B						
Stay arm 1, L=485, 400-600	400-600	485	—	—	—	130	3	20	K3001-05-N03
Stay arm 2, L=685, 601-800	601-800	685	—	—	—	130	4	20	K3001-07-N03
Stay arm 2, L=685, 601-800, 1 ML	601-800	685	390	1	—	130	4	18	K3001-57-N03
Stay arm 3, L=925, 801-1040, 1 ML	801-1040	925	537	1	—	130	6	20	K3001-09-N03
Stay arm 4, L=1165, 1041-1280, 1 ML	1041-1280	1165	624	1	—	130	7	20	K3001-11-N03
Stay arm 2, L=685, 601-800, 1 MR	601-800	685	390	—	1	130	4	18	K3021-57-N03
Stay arm 3, L=925, 801-1040, 1 MR	801-1040	925	537	—	1	130	6	20	K3021-09-N03
Stay arm 4, L=1165, 1041-1280, 1 MR	1041-1280	1165	624	—	1	130	7	20	K3021-11-N03



Stay arm

Stay arm

Stay arm

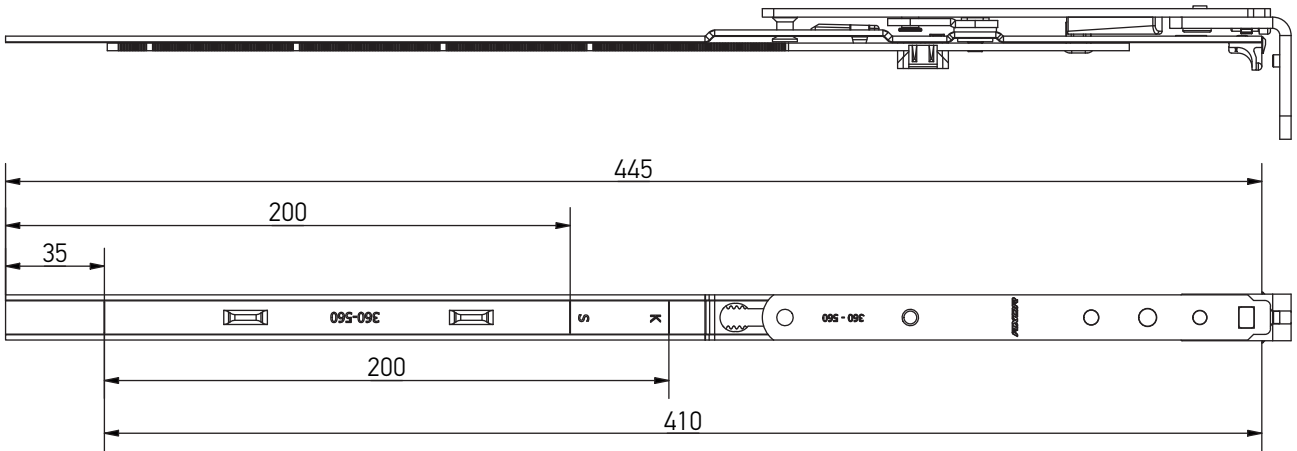

Possible mounting options

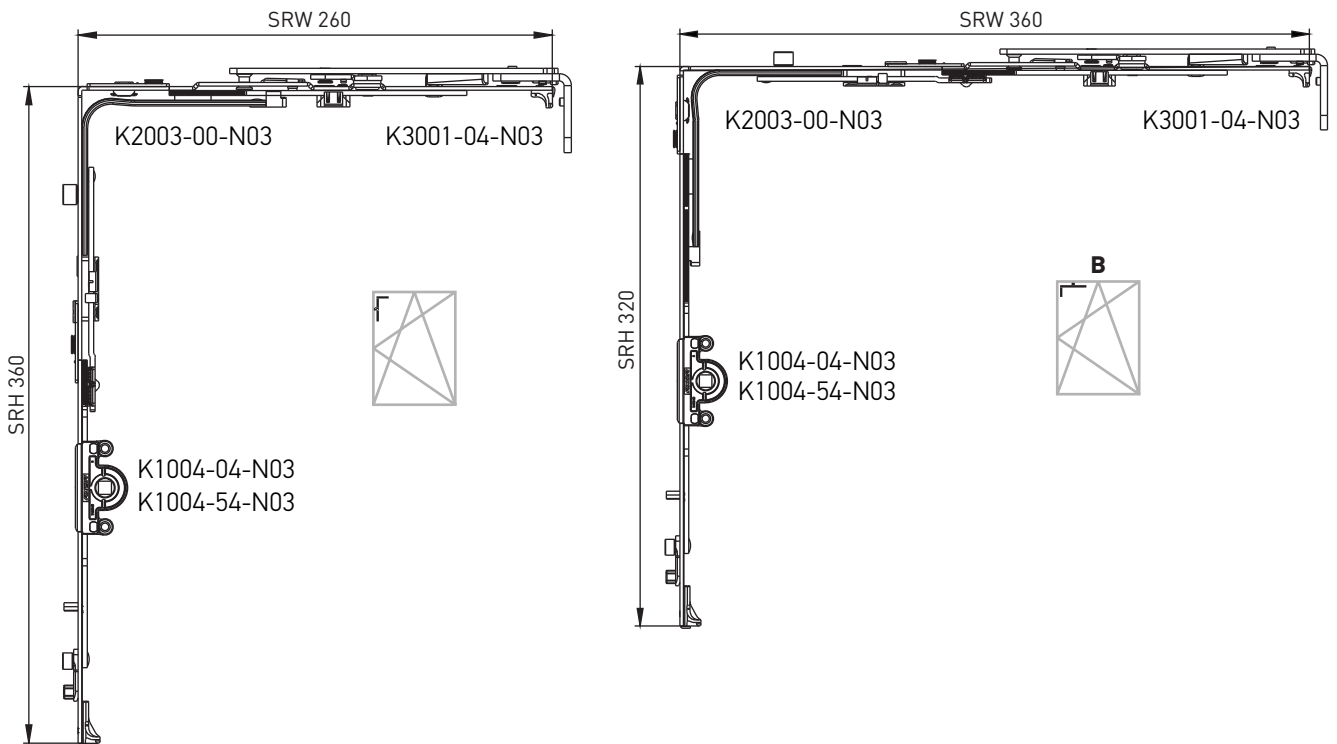

Do not connect with the Middle lock

Description	SRW (mm)	Dimensions							Part No.
		A	B						
Stay arm 0, L=410, 360-560	360-560	410	—	—	—	130	3	20	K3001-04-N03



Stay arm, sash part

Stay arm

Stay arm, sash part

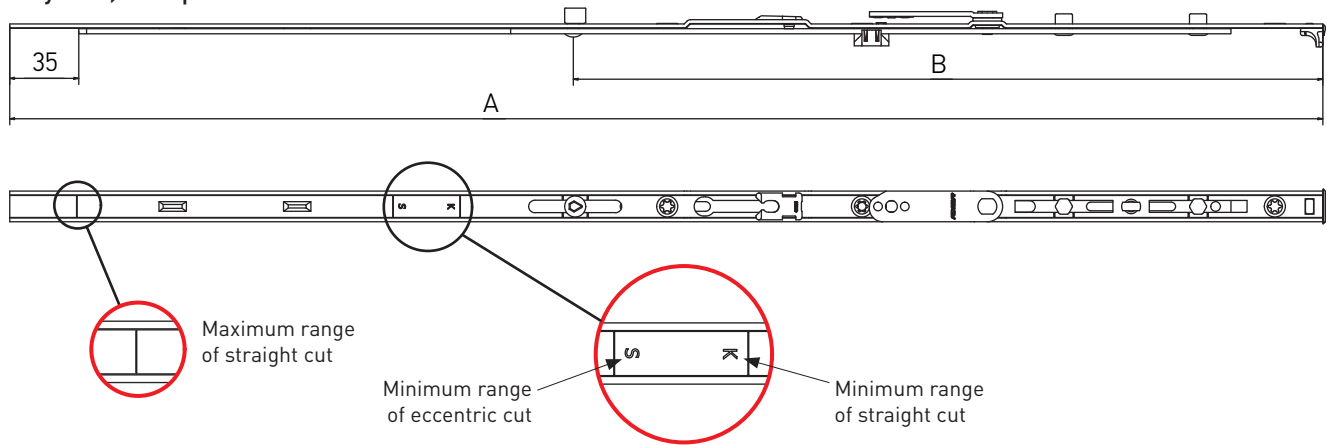

Stay arm, sash part, 1 MR

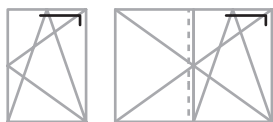
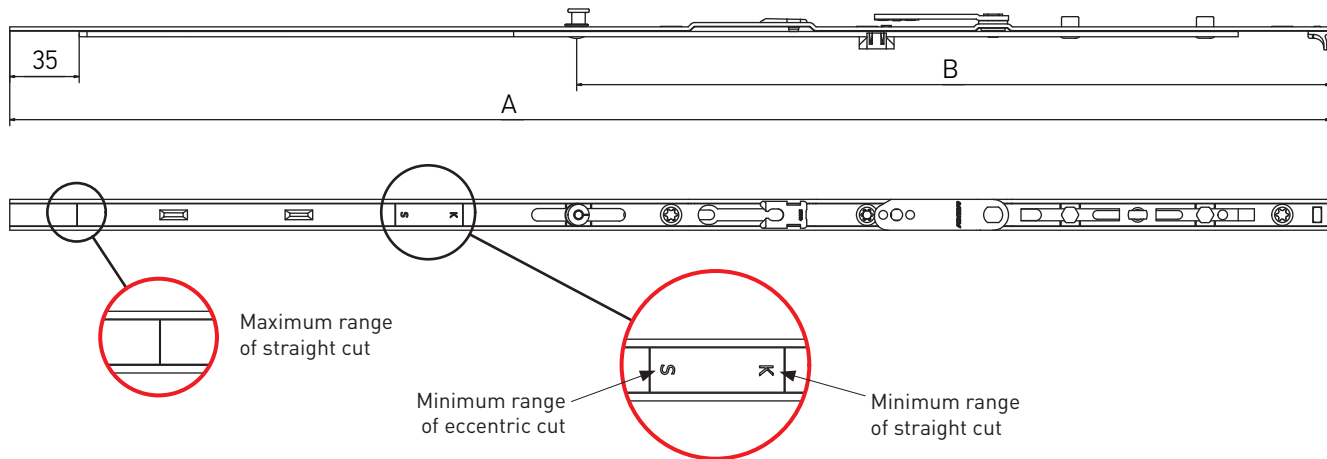

- for 18-22 mm sash overlap;
- sash rebate gap min. 12 mm;

Description	SRW (mm)	Dimensions							Part No.
		A	B						
Stay arm, sash part, L= 485, 400-600	400-600	485	—	—	—	130	3	20	K3013-05-N03
Stay arm, sash part, L= 685, 601-800	601-800	685	—	—	—	130	4	20	K3013-07-N03
Stay arm, sash part, L= 685, 601-800, 1 ML	601-800	685	390	1	—	130	4	20	K3013-57-N03
Stay arm, sash part, L= 925, 801-1040, 1 ML	801-1040	925	537	1	—	130	6	10	K3013-09-N03
Stay arm, sash part, L= 1165, 1041-1280, 1 ML	1041-1280	1165	624	1	—	130	7	10	K3013-11-N03
Stay arm, sash part, L= 925, 801-1040, 1 MR	801-1040	925	537	—	1	130	6	10	K3023-09-N03
Stay arm, sash part, L= 1165, 1041-1280, 1 MR	1041-1280	1165	624	—	1	130	7	10	K3023-11-N03



Stay arm, sash part FLAX pin

Stay arm

Stay arm FLAX pin

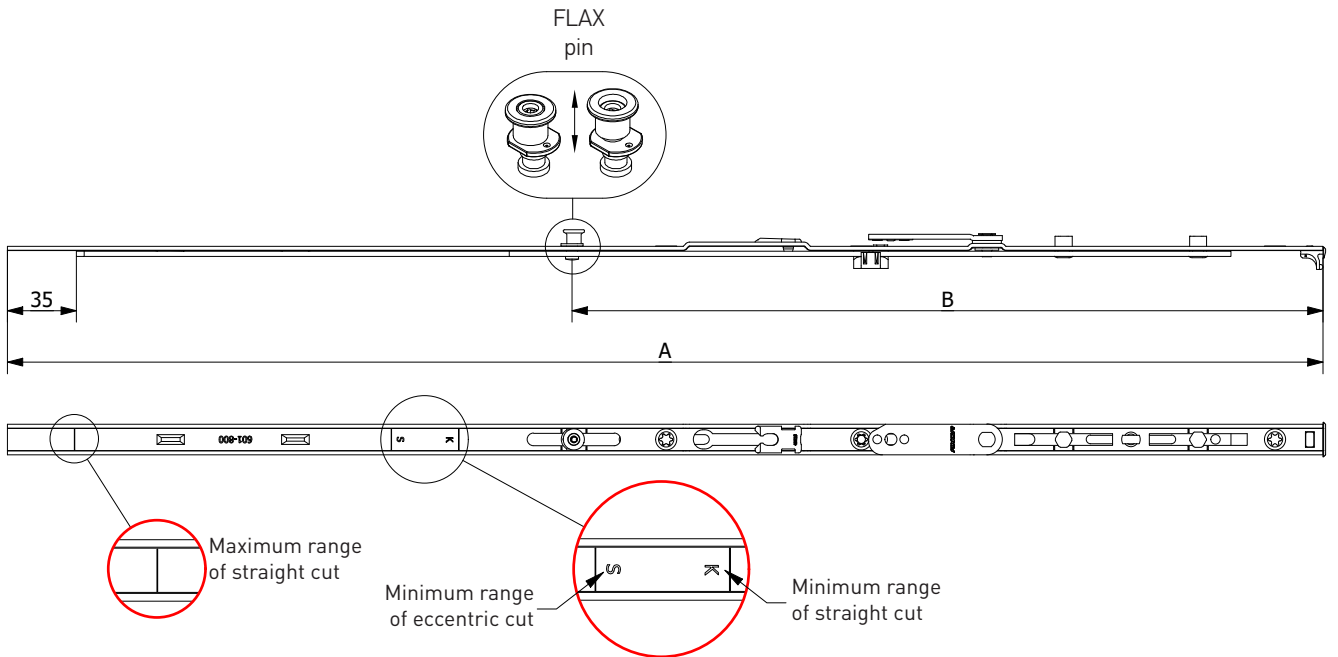

- for 18-22 mm sash overlap;
- sash rebate gap min. 12 mm;

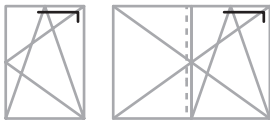

Description	SRW (mm)	Dimensions						Part No.
		A	B					
Stay arm, sash part L=685, 601-800, 1FX	601-800	685	390	1	130	3	20	K3037-57-N03
Stay arm, sash part L=925, 801-1040, 1FX	801-1040	925	537	1	130	5	10	K3037-09-N03
Stay arm, sash part L=1165, 1041-1280, 1FX	1041-1280	1165	624	1	130	6	10	K3037-11-N03



Stay arm, sash part “First Tilt”

Stay arm

Stay arm, sash part “First Tilt”

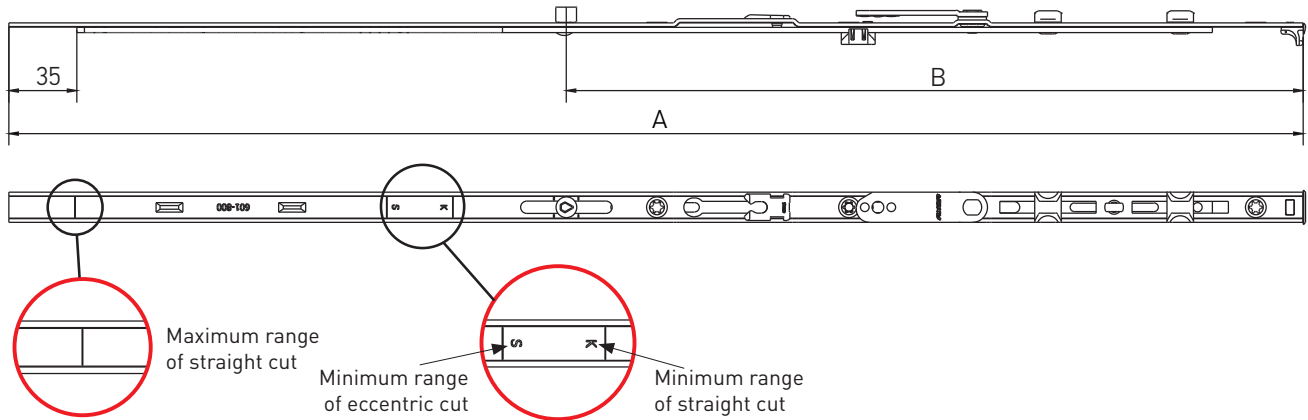

Stay arm, sash part “First Tilt”, 1 MR

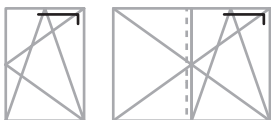
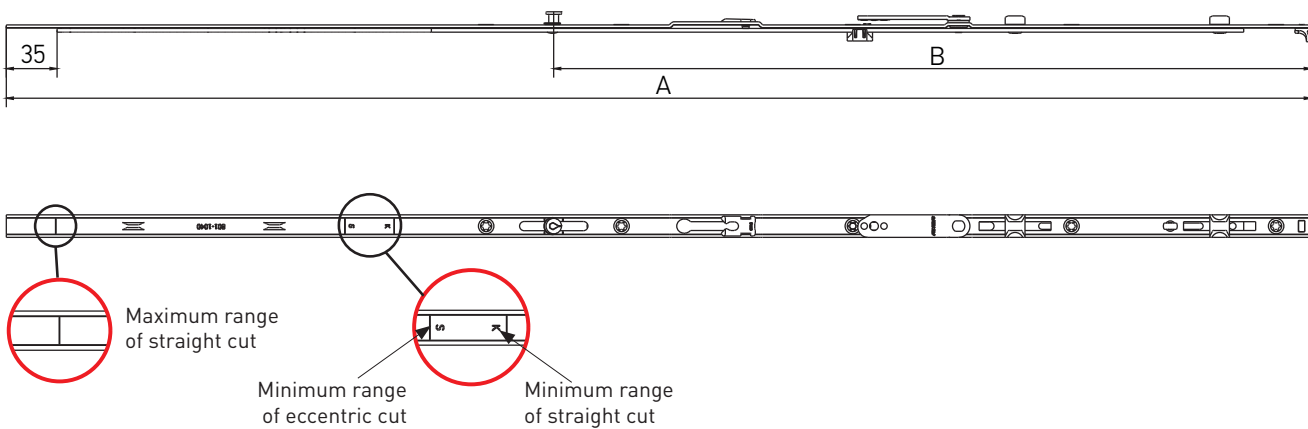

- for 18-22 mm sash overlap;
- sash rebate gap min. 12 mm;

Description	SRW (mm)	Dimensions						Part No.	
		A	B						
Stay arm, sash part “FIRST TILT”, L=485, 400-600	400-600	485	—	—	—	130	3	20	K3029-05-N03
Stay arm, sash part “FIRST TILT”, L=685, 601-800	601-800	685	—	—	—	130	4	20	K3029-07-N03
Stay arm, sash part «FIRST TILT», L=685, 601-800, 1 ML	601-800	685	390	1	—	130	4	20	K3029-57-N03
Stay arm, sash part «FIRST TILT», L=825, 801-1040, 1 ML	801-1040	825	537	1	—	130	6	10	K3029-09-N03
Stay arm, sash part «FIRST TILT», L=1165, 1041-1280, 1 ML	1041-1280	1165	624	1	—	130	7	10	K3029-11-N03
Stay arm, sash part TBT, L=925, 801-1040, 1 MR	801-1040	925	537	—	1	130	6	10	K3032-09-N03
Stay arm, sash part TBT, L=1165, 1041-1280, 1 MR	1041-1280	1165	624	—	1	130	7	10	K3032-11-N03

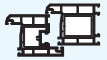

Stay arm, frame part

Stay arm

Stay arm, frame part

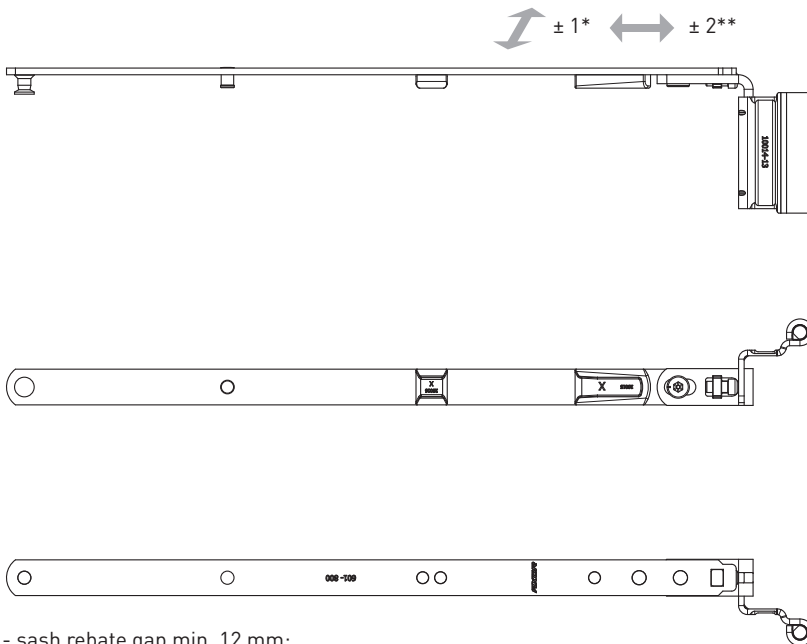

- sash rebate gap min. 12 mm;

* clamp adjustment, mm

** horizontal adjustment, mm

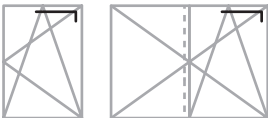

Description	SRW (mm)	Side opening	A	C	B	kg		Part No.
Stay arm, frame part 13, L=248, 400-600, left	400-600	L	12	20	13	130	10	K3011-02-L03
Stay arm, frame part 13, L=248, 400-600, right	400-600	R	12	20	13	130	10	K3011-02-R03
Stay arm, frame part 13, L=319, 601-800, left	601-800	L	12	20	13	130	10	K3011-03-L03
Stay arm, frame part 13, L=319, 601-800, right	601-800	R	12	20	13	130	10	K3011-03-R03
Stay arm, frame part 13, L=449, 801-1040, left	801-1040	L	12	20	13	130	10	K3011-04-L03
Stay arm, frame part 13, L=449, 801-1040, right	801-1040	R	12	20	13	130	10	K3011-04-R03
Stay arm, frame part 13, L=539, 1041-1280, left	1041-1280	L	12	20	13	130	10	K3011-05-L03
Stay arm, frame part 13, L=539, 1041-1280, right	1041-1280	R	12	20	13	130	10	K3011-05-R03

A - sash rebate gap / C - sash overlap / B - sash groove position



Stay arm, sash part “First Tilt” FLAX pin

Stay arm

Stay arm, sash part “First Tilt” FLAX pin

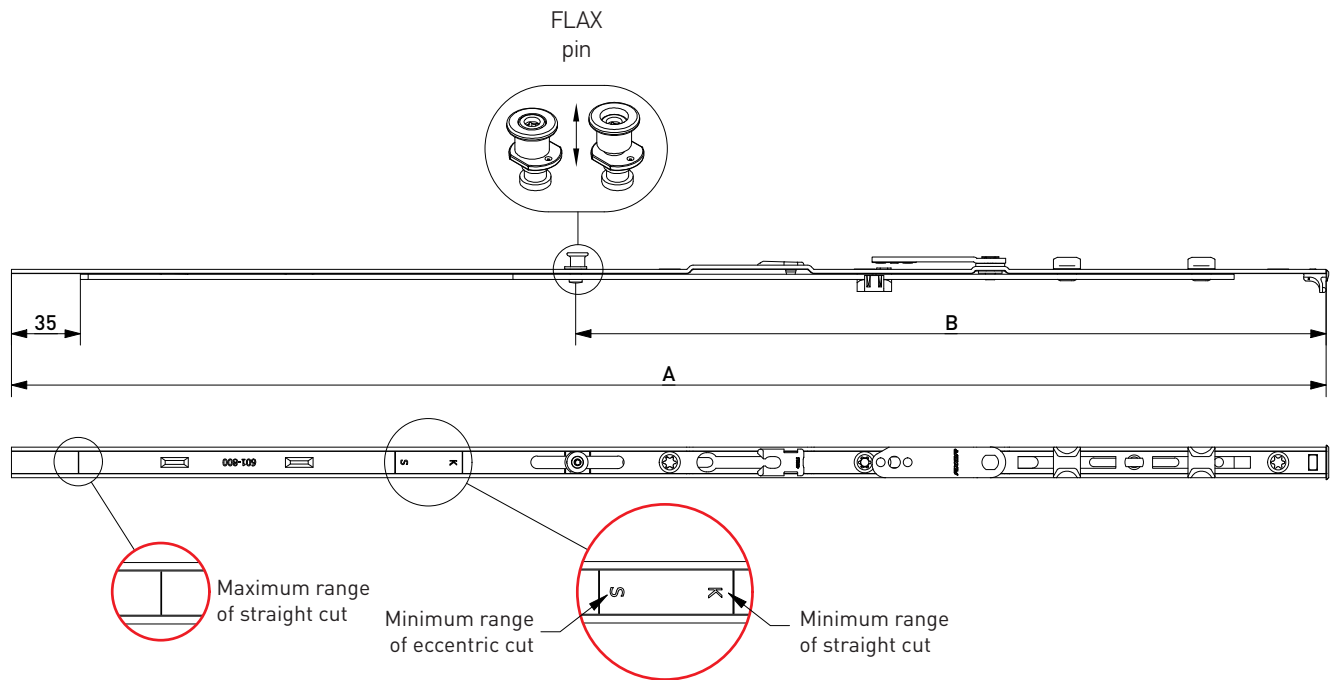

- for 18-22 mm sash overlap;
- sash rebate gap min. 12 mm;

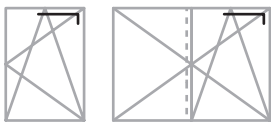

Найменування	ШСФ (мм)	Розміри						Артикул
		A	B					
Stay arm, sash part "FIRST TILT" L=685, 601-800, 1FX	601-800	685	390	1	130	3	20	K3038-57-N03
Stay arm, sash part "FIRST TILT" L=925, 801-1040, 1FX	801-1040	925	537	1	130	5	10	K3038-09-N03
Stay arm, sash part "FIRST TILT" L=1165, 1041-1280, 1FX	1041-1280	1165	624	1	130	6	10	K3038-11-N03



Stay arm with micro-ventilation, frame part

Stay arm

Stay arm with micro-ventilation, frame part

(for use with sash stay arms and sash stay arms 1 MR, part no. K3013... and K3023...)

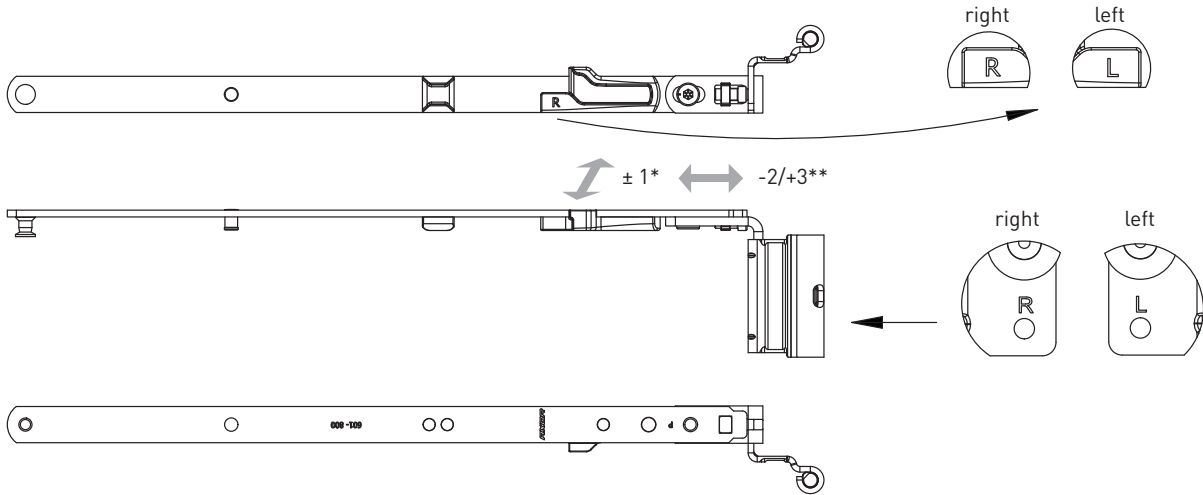

- sash rebate gap min. 12 mm;

* clamp adjustment, mm

** horizontal adjustment, mm

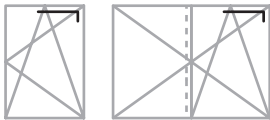

Description	SRW (mm)	Side opening	A	C	B	kg		Part No.
Stay arm, frame part 13, L=248, 400-600, with micro-ventilation, left	400-600	L	12	20	13	130	10	K3012-02-L03
Stay arm, frame part 13, L=248, 400-600, with micro-ventilation, right	400-600	R	12	20	13	130	10	K3012-02-R03
Stay arm, frame part 13, L=327, 601-800, with micro-ventilation, left	601-800	L	12	20	13	130	10	K3012-03-L03
Stay arm, frame part 13, L=327, 601-800, with micro-ventilation, right	601-800	R	12	20	13	130	10	K3012-03-R03
Stay arm, frame part 13, L=439, 801-1040, with micro-ventilation, left	801-1040	L	12	20	13	130	10	K3012-04-L03
Stay arm, frame part 13, L=439, 801-1040, with micro-ventilation, right	801-1040	R	12	20	13	130	10	K3012-04-R03
Stay arm, frame part 13, L=518, 1041-1280, with micro-ventilation, left	1041-1280	L	12	20	13	130	10	K3012-05-L03
Stay arm, frame part 13, L=518, 1041-1280, with micro-ventilation, right	1041-1280	R	12	20	13	130	10	K3012-05-R03



Stay arm, frame part “First Tilt”

Stay arm

Stay arm, frame part “First Tilt”

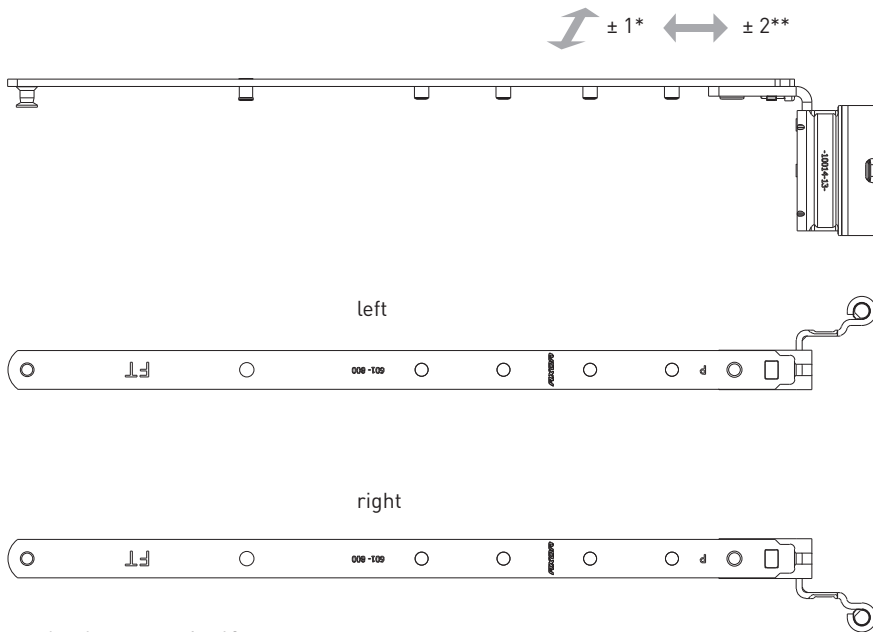

- sash rebate gap min. 12 mm;

* clamp adjustment, mm

** horizontal adjustment, mm

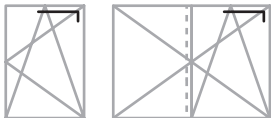

Description	SRW (mm)	Side opening	A	C	B	kg	Box	Part No.
Stay arm, frame part TBT L=223, 400-600, 13 mm, left	400-600	L	12	20	13	130	10	K3033-02-L03
Stay arm, frame part TBT L=223, 400-600, 13 mm, right	400-600	R	12	20	13	130	10	K3033-02-R03
Stay arm, frame part TBT L=327, 601-800, 13 mm, left	601-800	L	12	20	13	130	10	K3033-03-L03
Stay arm, frame part TBT L=327, 601-800, 13 mm, right	601-800	R	12	20	13	130	10	K3033-03-R03
Stay arm, frame part TBT L=439, 801-1040, 13 mm, left	801-1040	L	12	20	13	130	10	K3033-04-L03
Stay arm, frame part TBT L=439, 801-1040, 13 mm, right	801-1040	R	12	20	13	130	10	K3033-04-R03
Stay arm, frame part TBT L=518, 1041-1280, 13 mm, left	1041-1280	L	12	20	13	130	10	K3033-05-L03
Stay arm, frame part TBT L=518, 1041-1280, 13 mm, right	1041-1280	R	12	20	13	130	10	K3033-05-R03



Stay arm "First Tilt"*

Stay arm

Stay arm "First Tilt"*

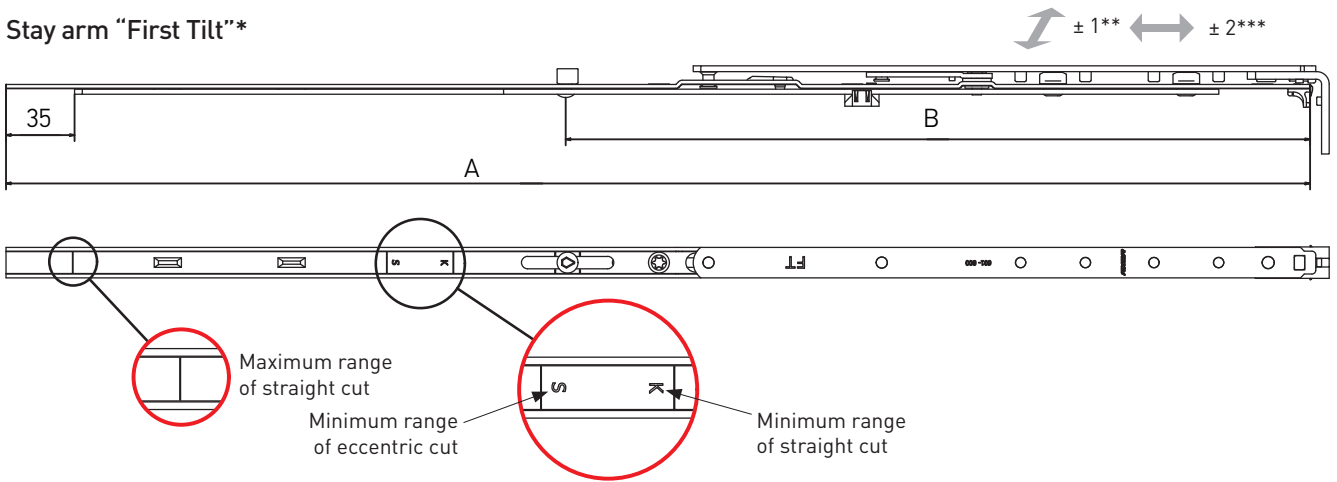

Stay arm "First Tilt"*, 1 MR

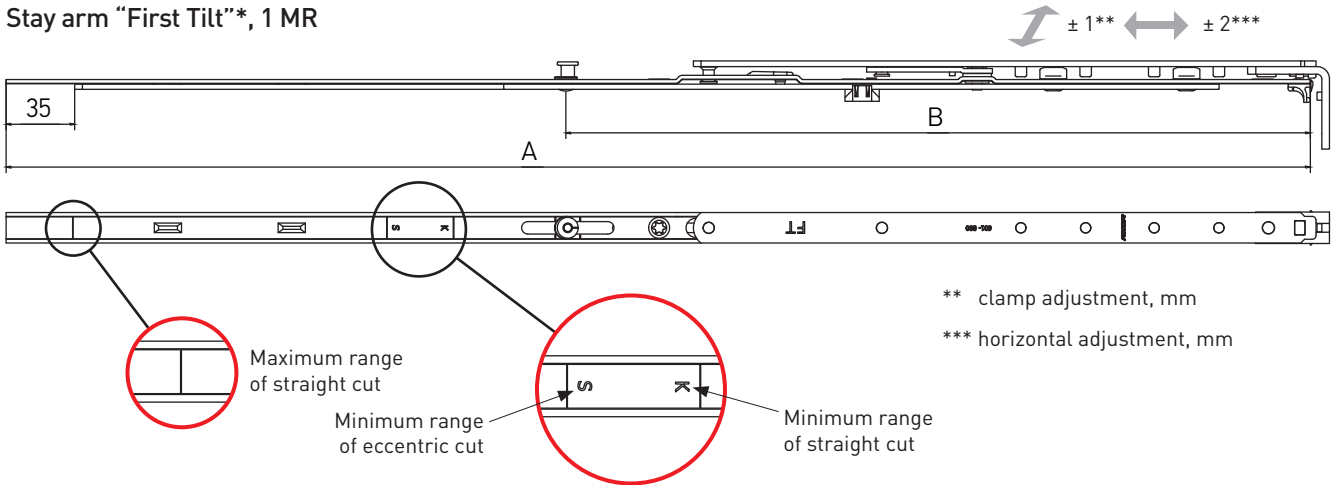

** clamp adjustment, mm
*** horizontal adjustment, mm

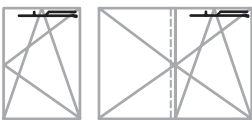

- for 18-22 mm sash overlap;
- sash rebate gap min. 12 mm;
- they are used together with corner transmission and a special tilt locking plate instead of the bottom extension [see: "Hardware set combinations" section].

Description	SRW (mm)	Dimensions							Part No.
		A	B						
Stay arm 1, "First Tilt", L=485, 400-600	400-600	485	—	—	—	130	3	20	K3014-05-N03
Stay arm 2, "First Tilt", L=685, 601-800	601-800	685	—	—	—	130	4	20	K3014-07-N03
Stay arm 3, "First Tilt", L=915, 801-1040, 1 ML	801-1040	915	537	1	—	130	6	10	K3014-09-N03
Stay arm 4, "First Tilt", L=1165, 1041-1280, 1 ML	1041-1280	1165	624	1	—	130	7	10	K3014-11-N03
Stay arm 3, "First Tilt", L=915, 801-1040, 1 MR	801-1040	915	537	—	1	130	6	10	K3024-09-N03
Stay arm 4, "First Tilt", L=1165, 1041-1280, 1 MR	1041-1280	1165	624	—	1	130	7	10	K3024-11-N03



Turn stay arm

Stay arm

Turn stay arm

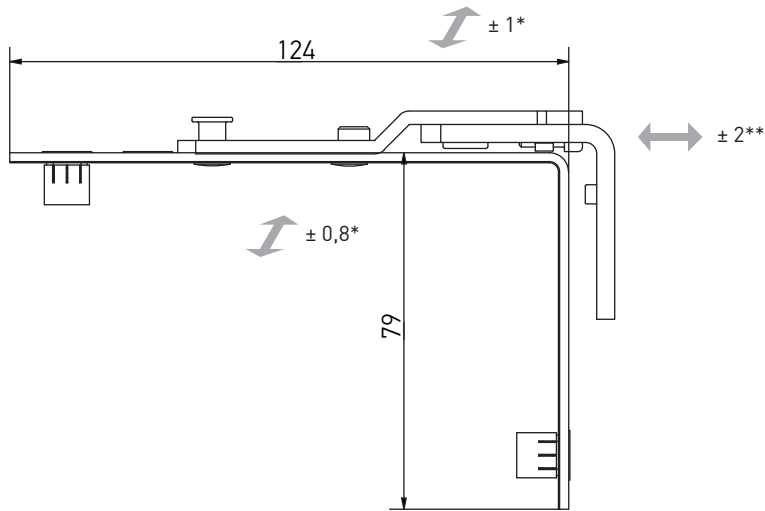

Turn stay arm

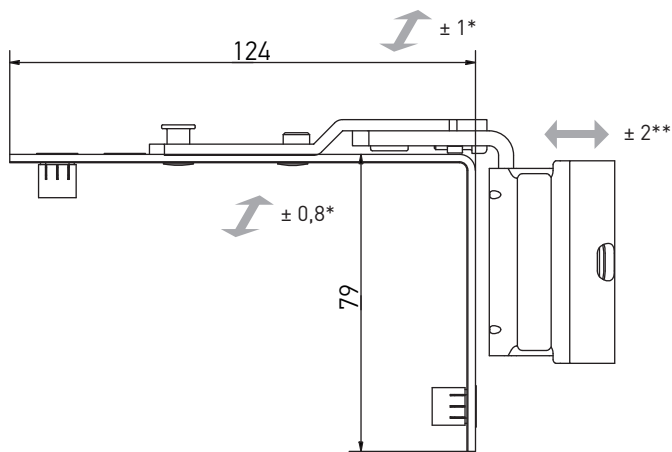

* clamp adjustment, mm

** horizontal adjustment, mm

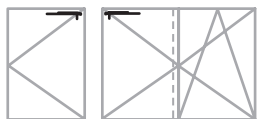

Description	SRW (mm)					Part No.
Turn stay arm	280-1280	0	4	100	100	K5002-00-N03
Turn stay arm 12/20-13 left	280-1200	0	3	100	25	K5014-13-L03
Turn stay arm 12/20-13 right	280-1200	0	3	100	25	K5014-13-R03
Turn stay arm 12/20-9 left	280-1200	0	3	100	25	K5014-09-L03
Turn stay arm 12/20-9 right	280-1200	0	3	100	25	K5014-09-R03



Tilt stay arm

Stay arm

Tilt stay arm

General view and stay-arm position at a frame

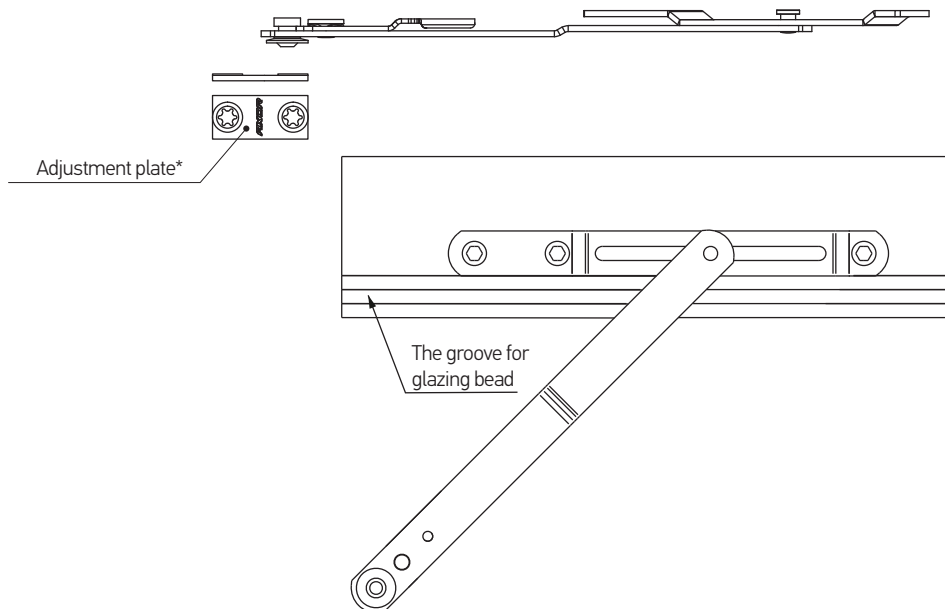

Information for installation

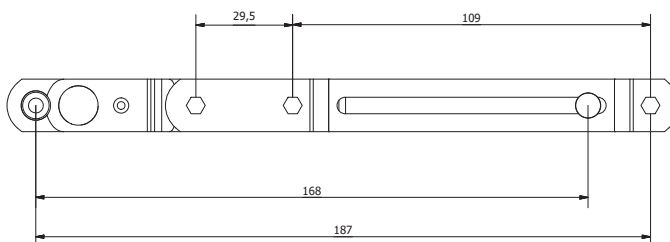
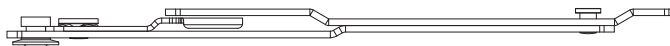

Description	SRW (mm)					Part No.
Tilt stay arm	450-1710	0	3	45	100	A7017-00-N03
Adjustment plate for the tilt stay arm	—	—	—	—	—	A7039-00-N03

* - To install stay arm vertically



Tilt stay arm

Stay arm

Tilt stay arm

General view and stay-arm position at a frame

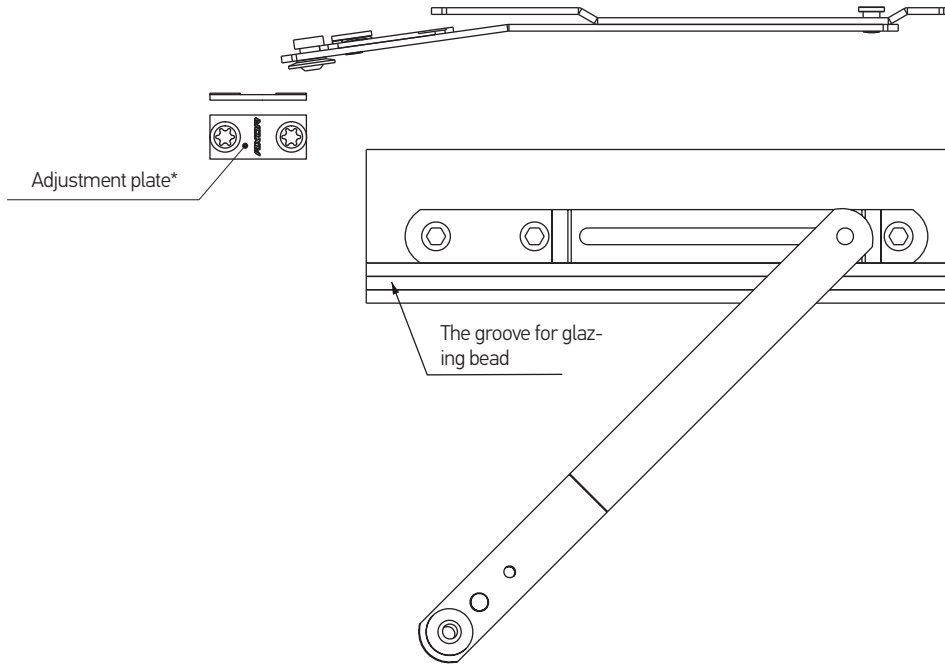

Information for installation

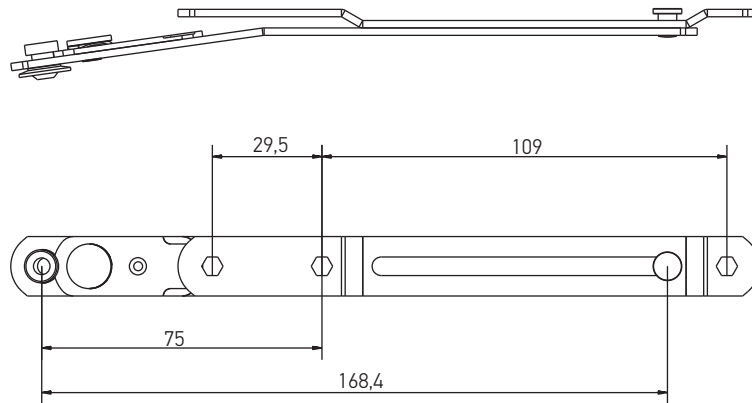

Description	SRW (mm)			kg		Part No.
Tilt stay arm	450-1710	0	3	45	100	A7107-00-N03
Adjustment plate for the tilt stay arm	—	—	—	—	—	A7039-00-N03

* - To install stay arm vertically

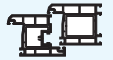

Additional stay arm

Stay arm

Additional stay arm, frame part

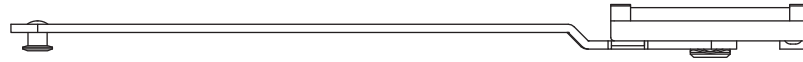

- installation when the sash rebate width is from 1200 mm
- for left and right opening
- profile-dependent element

Additional stay arm, sash part

Straight cut

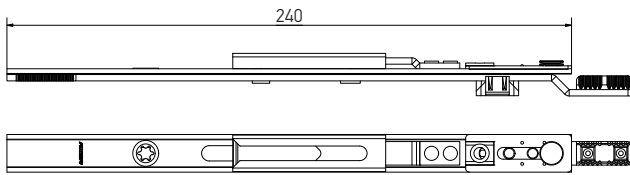

Eccentric cut

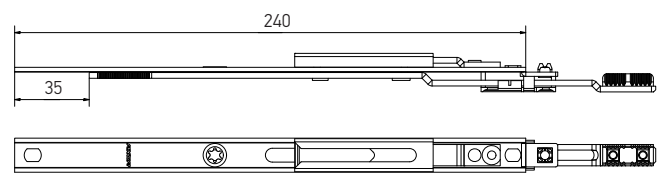

- installation when the sash rebate width is from 1200 mm
- for left and right opening

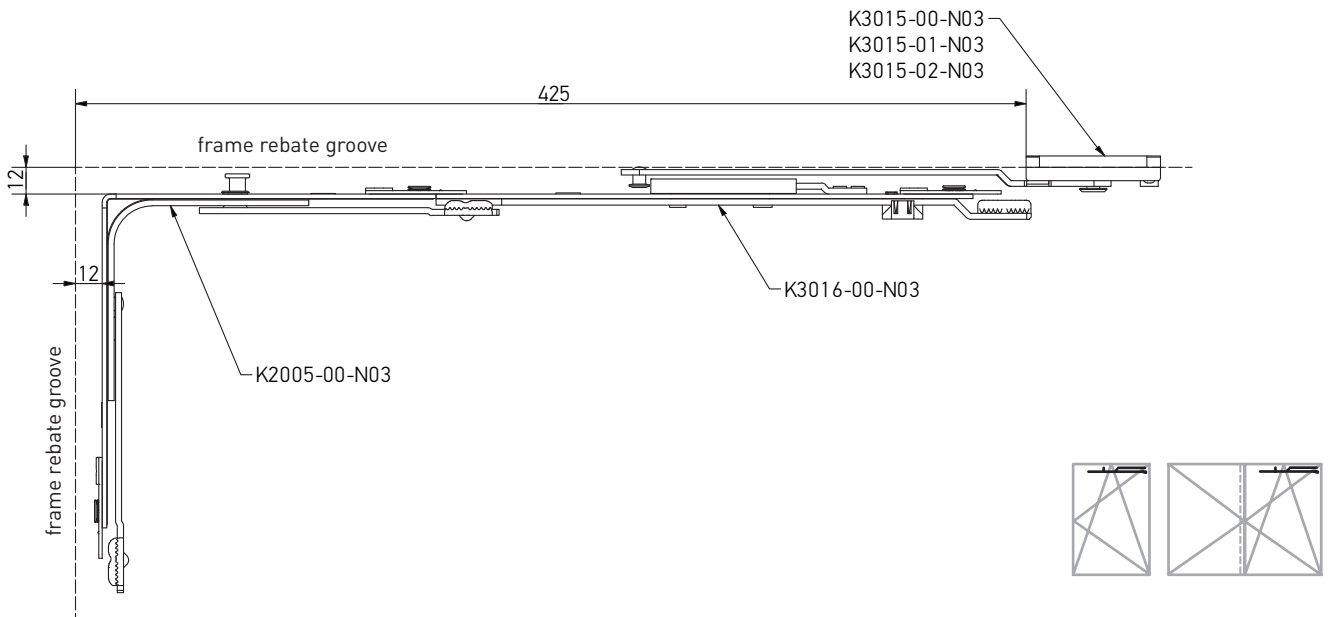

Description	SRW (mm)					Part No.
Additional stay arm, frame part, 1200-1520 (ALUPLAST)	1200-1520	—	2	130	20	K3015-00-N03
Additional stay arm, frame part, 1200-1520 (WDS)	1200-1520	—	2	130	20	K3015-01-N03
Additional stay arm, frame part, 1200-1520 (GEALAN)	1200-1520	—	2	130	20	K3015-02-N03
Additional stay arm, sash part, straight cut L=240, 1200-1520	1200-1520	—	2	130	20	K3016-00-N03
Additional stay arm, sash part, eccentric cut L=240, 1200-1520	1200-1520	—	2	130	20	K3036-00-N03

AXORTM

KOMFORT LINE K-3

Additional elements

AXOR

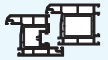

Wrong operation safety device with sash lifter

Additional elements

Wrong operation safety device with sash lifter

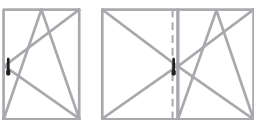
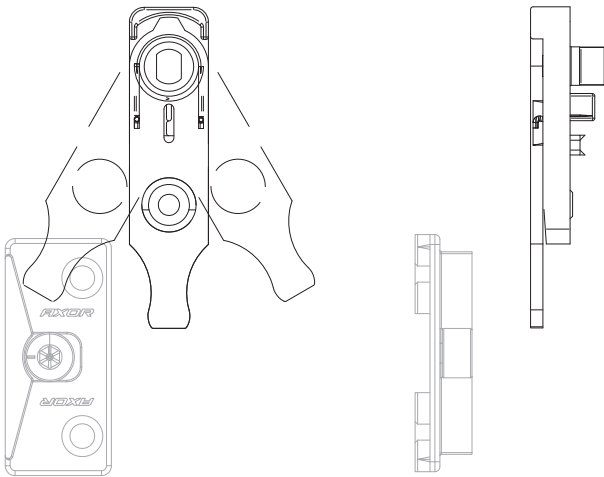

Description	Side opening	A	C	B	kg			Part No.
Wrong operation safety device with sash lifter	L/R	—	—	—	—	1	100	A7001-00-N03
Lifting plate	Look at the section "Profile-dependent elements"							
Lifting plate plate for double-sash window	L/R	12	—	09-13	—	2	250	A6001-00-N03

A - sash rebate gap / C - sash overlap / B - sash groove position



Single sash lifter

Additional elements

Single sash lifter

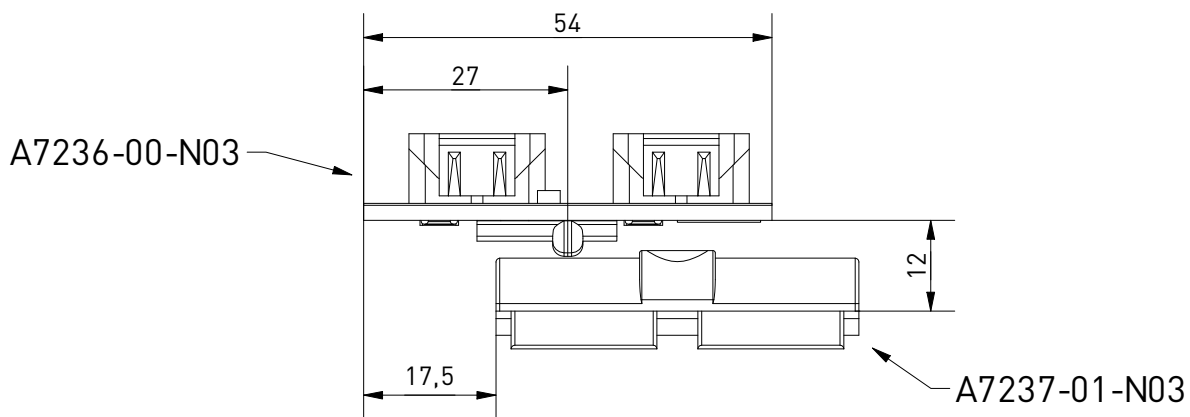
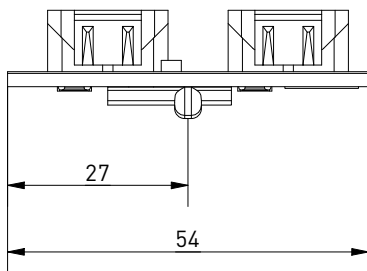
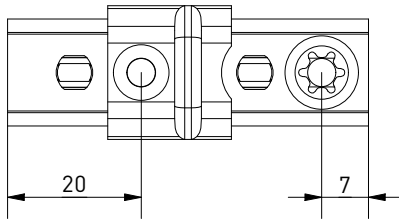

The single sash lifter A7236-00-N03 use together with the suitable frame part A7237-XX-N03.

The suitable frame part (A7237-XX-N03) can be found on p. 223.



Description	Dimensions			Part No.
Single sash lifter	54	2	100	A7236-00-N03
Frame part of sash lifter	Look at the section "Profile-dependent elements"			



Locking plate, integrated slit

Additional elements

Locking plate, integrated slit

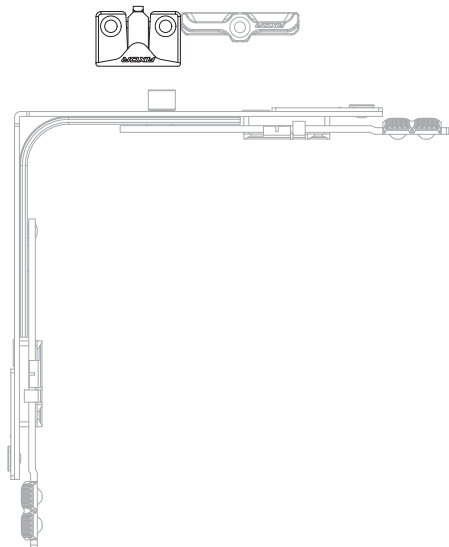

- use with standard and narrow corner transmissions;
- independent from type of opening (left or right);
- creates a 7-mm gap for ventilation;
- recommended for using with 8-position handle.

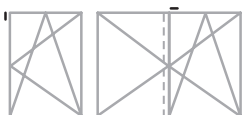
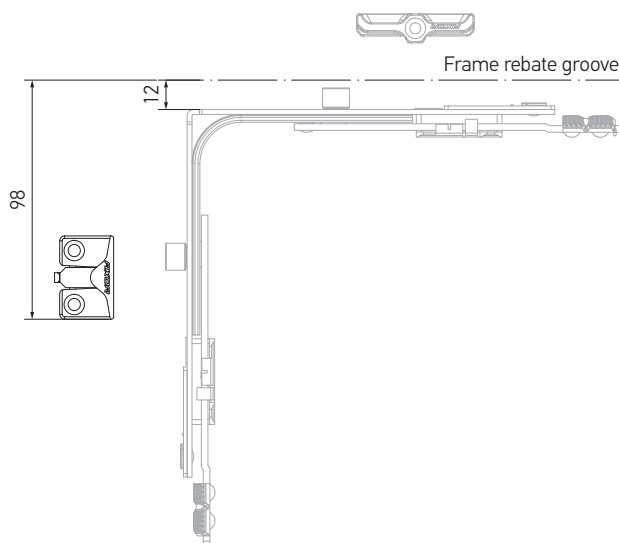

Description	Profile	Side opening	A	C	B			Part No.
Locking plate, integrated slit	Profile-dependent element*	L/R	12	—	9	2	100	A6005-09-N03
Locking plate, integrated slit	Profile-dependent element*	L/R	12	—	13	2	200	A6002-13-N03

*For part No. numbers of other components look at the section "Profile-dependent elements"

A - sash rebate gap / C - sash overlap / B - sash groove position



Balcony catch

Additional elements

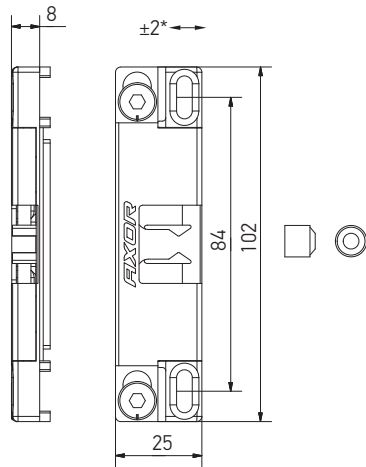

Balcony catch

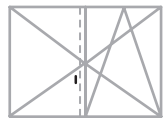
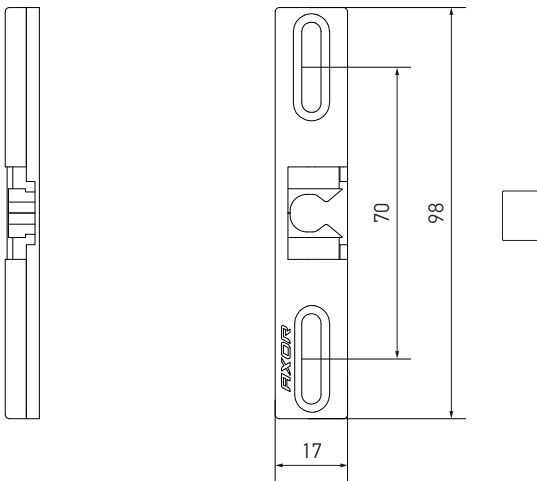

* the ability to adjust the fit

Balcony catch for double-sash gear M



Description	Side opening	A	C	B			Part No.
Balcony catch	L/R	12	—	13	2 / 4x35	100	A7184-13-N03
Balcony locking pin	—	—	—	—	1 / 4x30	1000	A7207-00-N00
Balcony catch for double-sash gear M	L/R	—	—	—	2 / 4x30	50	A7047-00-N03

A - sash rebate gap / C - sash overlap / B - sash groove position



Magnetic balcony catch

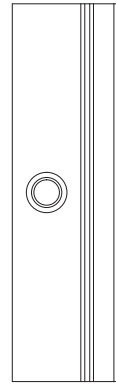

Additional elements

Magnetic balcony catch

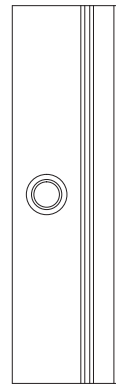
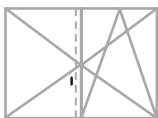

Magnetic balcony catch for double-sash gear



Description	Side opening	A	C	B			Part No.
Magnetic balcony catch, frame part	L/R	12	20	—	2 / 4×35	100	A7053-00-N03
Magnetic balcony catch, sash part, 13 th system	L/R	—	—	13	1/4×30	100	A7055-13-N03
Magnetic balcony catch, sash part, 9 th system	L/R	—	—	9	1/4×30	100	A7055-09-N03
Magnetic balcony catch for double-sash gear, frame part	L/R	—	—	—	2 / 4×30	100	A7054-00-N03

A - sash rebate gap / C - sash overlap / B - sash groove position



Concealed middle hinge

Additional elements

Concealed middle hinge, frame part

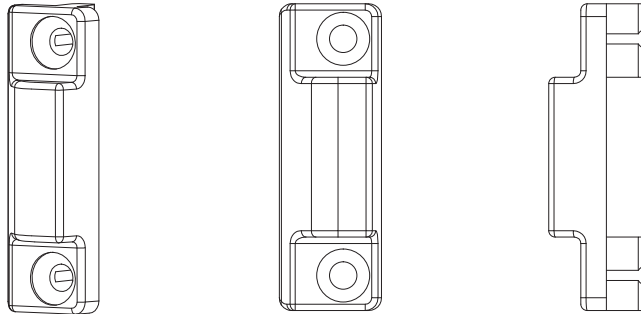

Concealed middle hinge, sash part

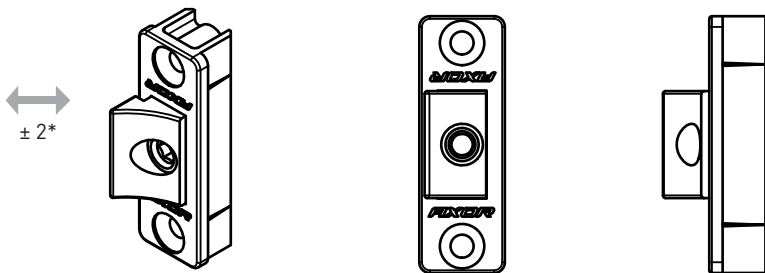

* horizontal adjustment, mm

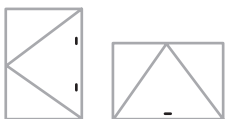

Description	SRH/SRW (mm)		A	C	B			Part No.
Concealed middle hinge frame part 12/20-13	751-1710	1						
	1711-2360	2	12	20	13	2 / 4x35	100	A7057-13-N03
Concealed middle hinge frame part 12/20-9	751-1710	1						
	1711-2360	2	12	20	9	2 / 4x35	100	A7057-09-N03
Concealed middle hinge sash part	751-1710	1	—	—	—			
	1711-2360	2	—	—	—	2 / 4x25	100	A7056-00-N03

A - sash rebate gap / C - sash overlap / B - sash groove position



Middle hinge

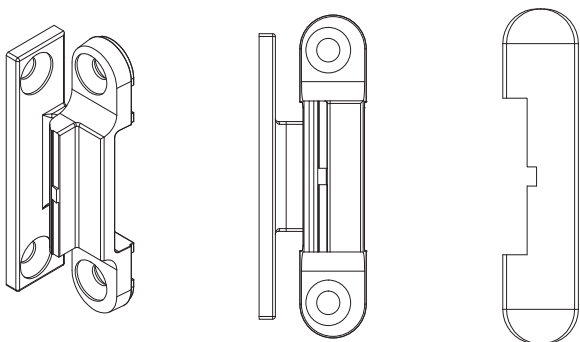

Additional elements

Middle hinge

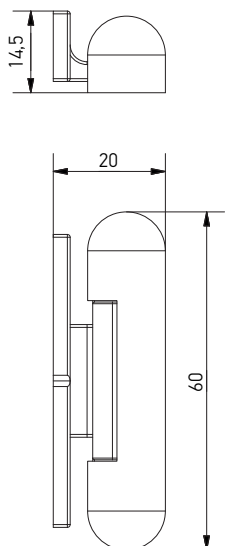

Middle hinge



Description	SRH/SRW (mm)				Part No.
Middle hinge, white	751-1710	1	4 / 4x25	100	A7185-00-N01
	1711-2360	2			
Middle hinge, brown	751-1710	1	4 / 4x25	100	A7185-00-N02
	1711-2360	2			
Middle hinge, gray anthracite	751-1710	1	4 / 4x25	100	A7185-00-N09
	1711-2360	2			



Stroke limiter 90°

Additional elements

Stroke limiter 90°

Stroke limiter 90° made of ZAMAK alloy

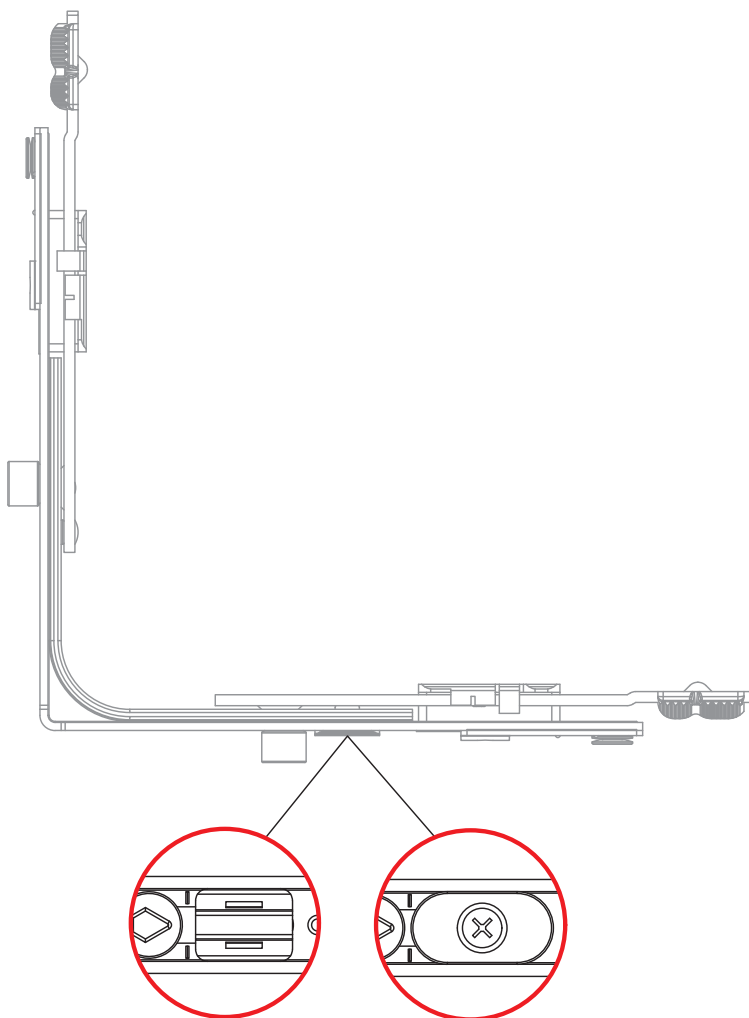
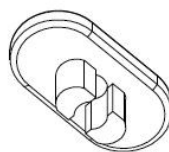
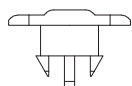
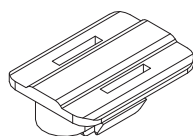
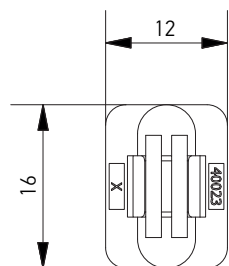

Description		Part No.
Stroke limiter 90°	4000	A7052-00-N03
Stroke limiter 90° made of ZAMAK alloy	1000	A7103-00-N03

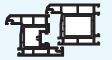

Cover for gear with customer logo

Additional elements

Cover for gear with customer logo, S

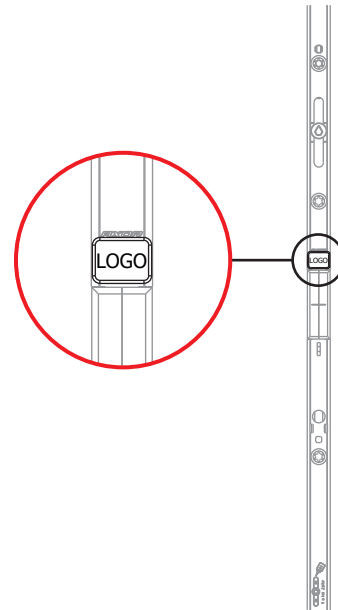
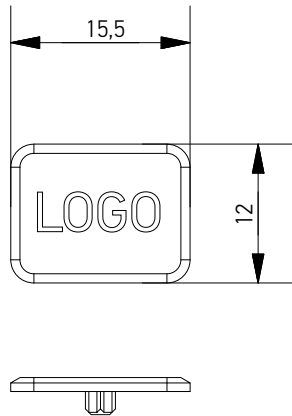

Cover for gear with customer logo, M

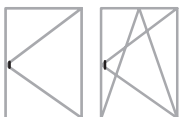
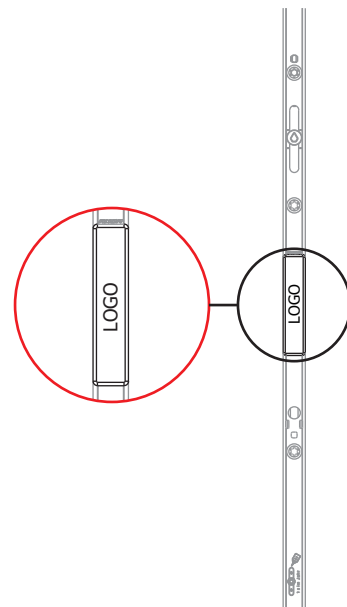
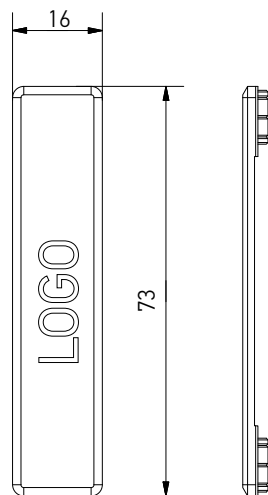

Description		Part No.
Cover for gear with customer logo, S	4000	A7060-00-N03
Cover for gear with customer logo, M	500	40001-00-N09



Protective plate for gear

Additional elements

Protective plate for gear

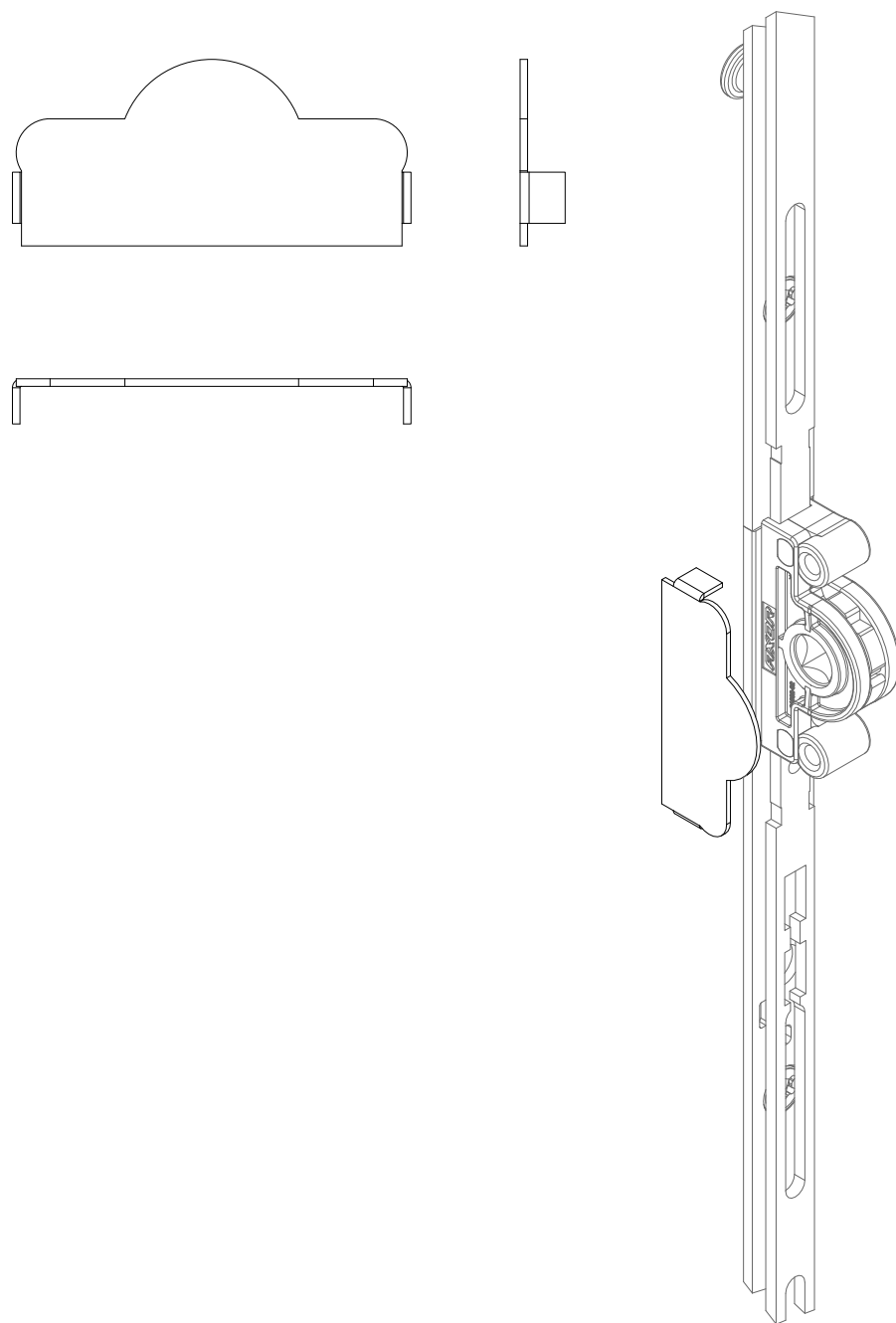

Description

Protective plate for gear



250

Part No.

A7061-00-N03

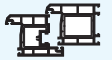

Stroke limiter

Additional elements

Stroke limiter

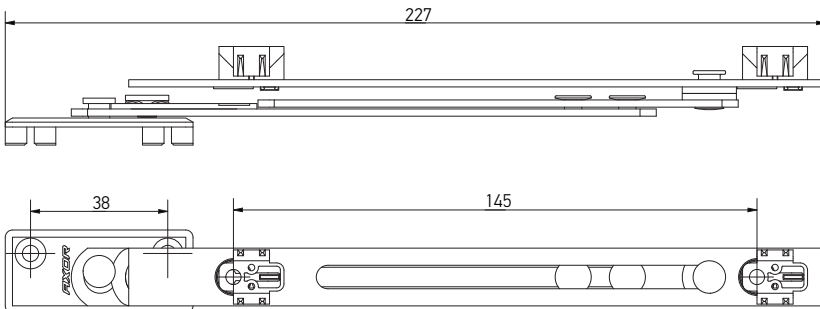

Possible mounting options with visible hinges

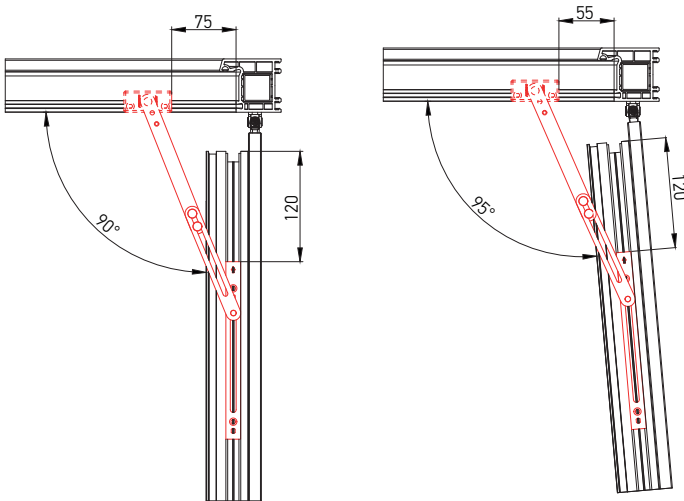

Possible mounting options with concealed hinges

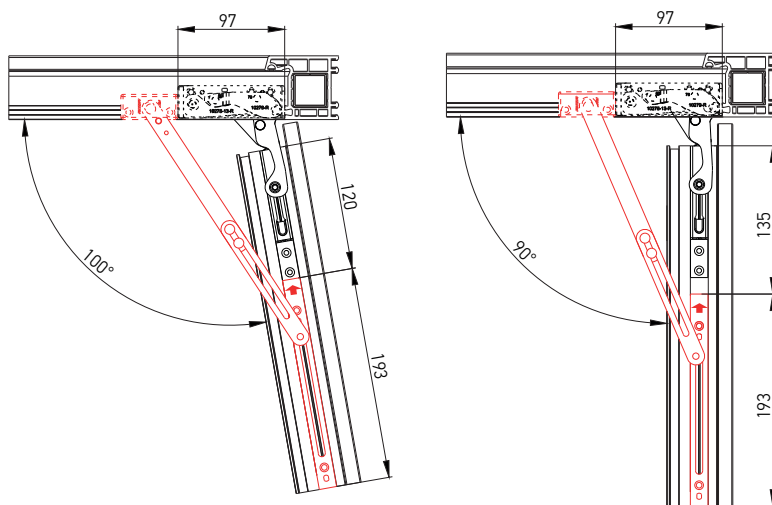

Description		 kg		Part No.
Stroke limiter	4	100	50	A7110-00-N03

AXORTM

KOMFORT LINE K-3

Hardware set combinations

AXOR

Tilt and turn set

Hardware set combinations

Tilt and turn set, straight cut.

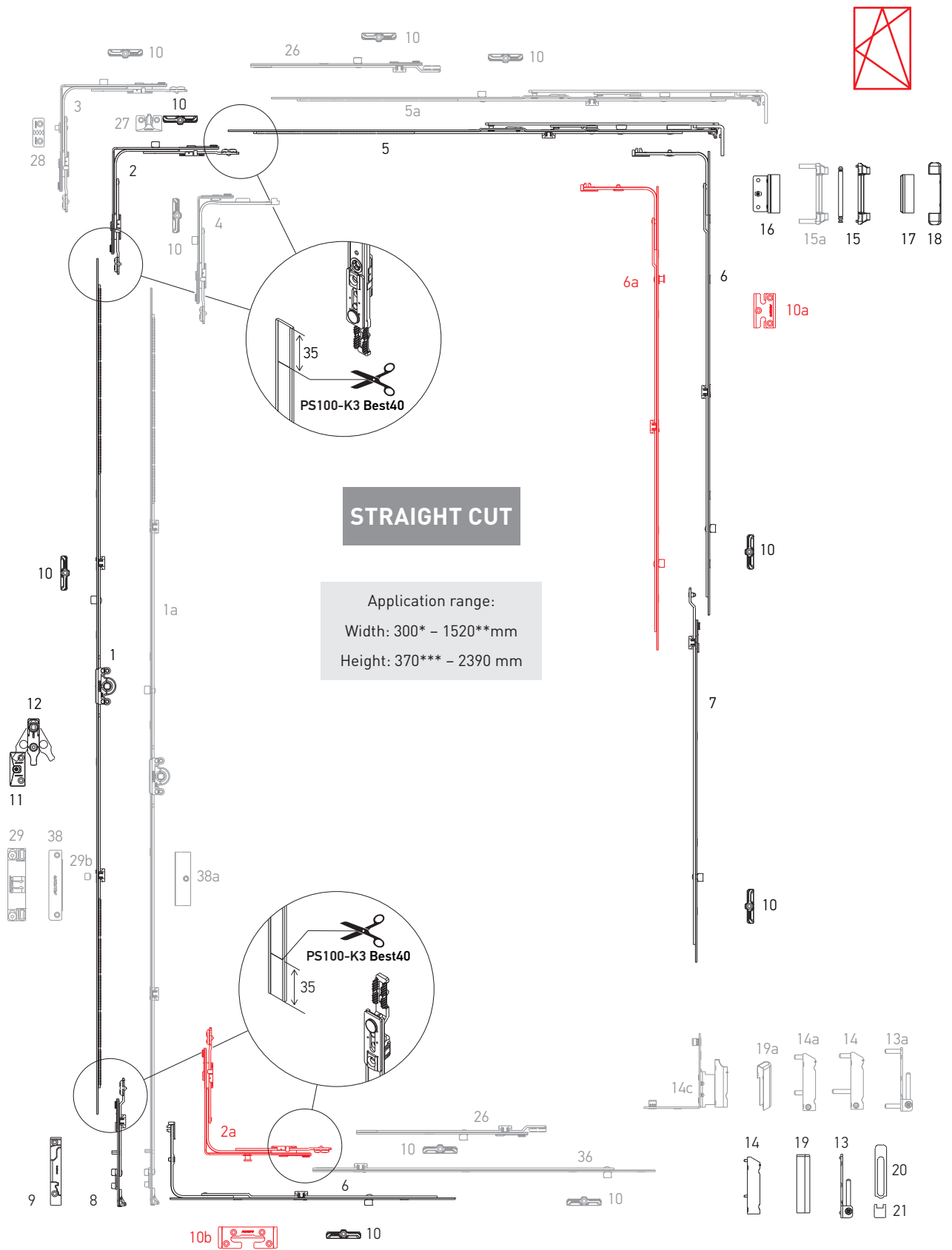

* with narrow corner transmission
 ** with the linear extension 240 mm
 *** with the constant gear K1004-04-N03



Tilt and turn set

Hardware set combinations

STRAIGHT CUT

Nº	Description	Application range by width	Application range by height	Part No.
1	Gear variable 0, L=320, 450-550	—	450-550	K1001-02-N03
	Gear variable 1, L=520, 551-750	—	551-750	K1001-04-N03
	Gear variable 2, L=1000, 751-1230, 1 ML	—	751-1230	K1001-09-N03
	Gear variable 3, L=1200, 950-1430, 1 ML	—	950-1430	K1001-11-N03
	Gear variable 4, L=1480, 1231-1710, 2 ML	—	1231-1710	K1001-14-N03
	Gear variable 5, L=1680, 1431-1910, 2 ML	—	1431-1910	K1001-16-N03
	Gear variable 6, L=2160, 1911-2390, 3 ML	—	1911-2390	K1001-21-N03
1a	Constant gear 0, L=435, G=140, 370-550*	—	370-550	K1004-04-N03
	Constant gear 1, L=385, G=175, 400-500*	—	400-500	K1004-03-N03
	Constant gear 2, L=565, G=200, 480-680*	—	480-680	K1004-05-N03
	Constant gear 3, L=805, G=300, 681-920*, 1 ML	—	681-920	K1004-08-N03
	Constant gear 4, L=1045, G=450, 921-1160*, 1 ML	—	921-1160	K1004-10-N03
	Constant gear 5, L=1285, G=600, 1161-1400*, 1 ML	—	1161-1400	K1004-12-N03
	Constant gear 6, L=1525, G=600, 1401-1640*, 2 ML	—	1401-1640	K1004-15-N03
	Constant gear 7, L=1765, G=600, 1641-1880*, 2 ML	—	1641-1880	K1004-17-N03
	Constant gear 8, L=1765, G=1000, 1641-1880*, 2 ML	—	1641-1880	K1004-18-N03
	Constant gear 9, L=2005, G=1000, 1881-2120*, 2 ML	—	1881-2120	K1004-20-N03
	Constant gear 10, L=2245, G=1000, 2121-2360*, 3 ML	—	2121-2360	K1004-22-N03
2	Corner transmission, 1 ML, 150×150	400-1280	450-2390	K2001-00-N03
2a	Corner transmission, 1 MR, 150×150	400-1280	450-2390	K2005-00-N03
3	Corner transmission, integrated slit, 1 ML, 150×150, left	400-1280	450-2390	K2004-00-L03
	Corner transmission, integrated slit, 1 ML, 150×150, right	400-1280	450-2390	K2004-00-R03
4	Narrow corner transmission, 1 ML, 50×150	300-400	450-2390	K2003-00-N03
		400-600	370-550*	
5	Stay arm 1, L=485, 400-600	400-600	—	K3001-05-N03
	Stay arm 2, L=685, 601-800	601-800	—	K3001-07-N03
	Stay arm 3, L=925, 801-1040, 1 ML	801-1040	—	K3001-09-N03
	Stay arm 4, L=1165, 1041-1280, 1 ML	1041-1280	—	K3001-11-N03
5a	Stay arm 2, L=685, 601-800, 1 ML	601-800	—	K3001-57-N03
6	Middle lock L=400, 1 ML	600-1000	600-1000	K4001-04-N03
	Middle lock L=650, 1 ML	850-1250	850-1250	K4001-06-N03
	Middle lock L=720, 1 ML	920-1320	920-1320	K4001-07-N03
	Middle lock L=820, 1 ML	1251-1430	1251-1430	K4001-08-N03
	Middle lock L=1130, 2 ML	—	1251-1730	K4001-11-N03
6a	Middle lock L=400, 1 MR + 1 ML	600-1000	600-1000	K4008-04-N03
	Middle lock L=650, 1 MR + 1 ML	850-1250	850-1250	K4008-06-N03
	Middle lock L=820, 1 MR + 1 ML	1251-1430	1251-1430	K4008-08-N03
	Middle lock L=1130, 1 MR + 2 ML	—	1251-1730	K4008-11-N03
7	Middle lock extension, 1 ML, 480 mm	—	1710-2210	K4005-05-N03
	Middle lock extension, 1 ML, 680 mm	—	2211-2390	K4005-07-N03
8	Bottom extension	—	450-800	K4009-00-N03
		—	801-2390	K4002-00-N03

Tilt and turn set
STRAIGHT CUT

Hardware set combinations

Nº	Description	Application range by width	Application range by height	Part No.
9	Tilt locking plate, right	—	—	***
	Tilt locking plate, left	—	—	***
10	Locking plate	—	—	***
10a	Locking plate safety	—	—	***
10b	Tilt locking plate safety	—	—	***
11	Lifting plate	—	751-2390	***
12	Wrong operation safety device with sash lifter	—	751-2390	A7001-00-N03
13	Corner bearing	—	—	A5002-00-N03
13a	Corner bearing 6x22	—	—	A5004-00-N03
14	Drill-in corner hinge 3x5	—	—	A5003-00-N03
14a	Drill-in corner hinge with gasket pressure adjustment 6x12	—	—	A5007-00-N03
14b	Drill-in corner hinge with gasket pressure adjustment 6x16/26	—	—	A5006-00-N03
14c	Rebate corner hinge 20/9 left	—	—	A5009-09-L03
	Rebate corner hinge 20/9 right	—	—	A5009-09-R03
	Rebate corner hinge 20/13 left	—	—	A5009-13-L03
	Rebate corner hinge 20/13 right	—	—	A5009-13-R03
15	Stay arm bearing 3x3	—	—	A5001-00-N03
15a	Stay arm bearing 6x24	—	—	A5005-00-N03
16	Top sash hinge	—	—	K5001-**-N03
17	Cover of top sash hinge	—	—	A7004-10-N****
18	Cover of stay arm bearing	—	—	A7005-10-N****
19	Cover of the drill-in corner hinge	—	—	A7006-10-N****
19a	Cover of rebate corner hinge, left / right	—	—	A7009-00-L/R****
20	Top cover of corner bearing	—	—	A7008-10-N****
21	Bottom cover of corner bearing	—	—	A7007-10-N****
26	Extension lock 240 mm, 1 ML	—	—	K4003-02-N03
	Extension lock 480 mm, 1 ML	—	—	K4003-05-N03
27	Locking plate, integrated slit	—	—	***
28	Locking plate for adjustable integrated slit	—	—	***
29	Balcony catch	—	—	A7184-13-N03
29b	Balcony locking pin	—	—	A7207-00-N03
36	Extension lock for corner transmission 480 mm, 1 ML	—	—	K4010-00-N03
	Extension lock for corner transmission 680 mm, 1 ML	—	—	K4010-07-N03
	Extension lock for corner transmission 880 mm, 2 ML	—	—	K4010-09-N03
	Extension lock for corner transmission 480 mm, 1 MR	—	—	K4030-00-N03
38	Magnetic balcony catch, frame part	—	—	A7053-00-N03
38a	Magnetic balcony catch, sash part	—	—	A7055-**-N03

* – displaced from the center

** – according to displacement axis of sash groove (9 mm, 10 mm, 13 mm, 14 mm)

*** – look at the section "Profile-dependent elements"

**** – for decorative covers in other colors look at p. 27



Tilt and turn set "First Tilt"

Hardware set combinations

Tilt and turn set "First Tilt", straight cut

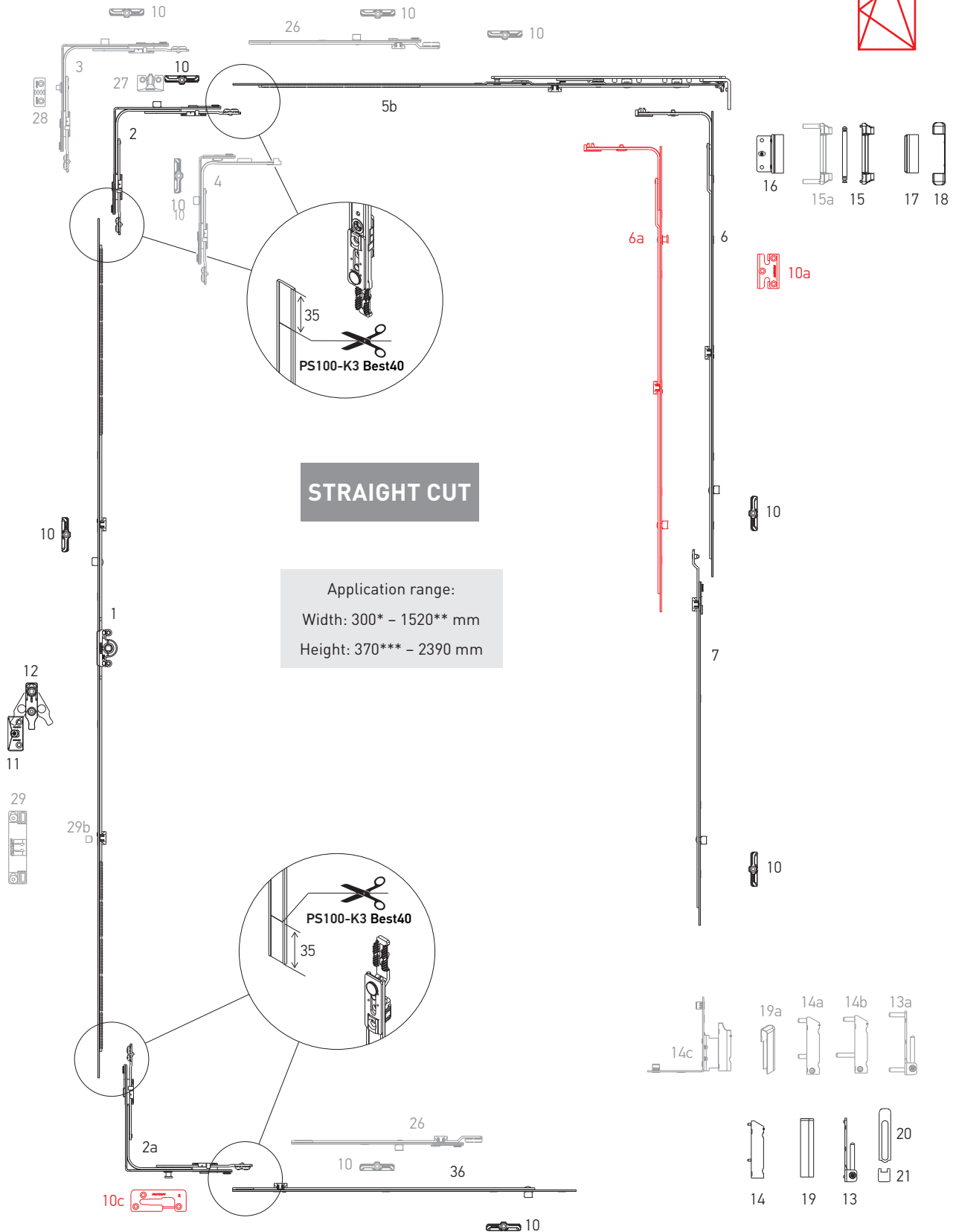

STRAIGHT CUT

Application range:
Width: 300* - 1520** mm
Height: 370*** - 2390 mm

* with narrow corner transmission
** with the linear extension 240 mm
***with the constant gear K1004-04-N03



Tilt and turn set "First Tilt"

STRAIGHT CUT

Hardware set combinations

Nº	Description	Application range by width	Application range by height	Part No.
1	Gear variable 0, L=320, 450-550	—	450-550	K1001-02-N03
	Gear variable 1, L=520, 551-750	—	551-750	K1001-04-N03
	Gear variable 2, L=1000, 751-1230, 1 ML	—	751-1230	K1001-09-N03
	Gear variable 3, L=1200, 950-1430, 1 ML	—	950-1430	K1001-11-N03
	Gear variable 4, L=1480, 1231-1710, 2 ML	—	1231-1710	K1001-14-N03
	Gear variable 5, L=1680, 1431-1910, 2 ML	—	1431-1910	K1001-16-N03
	Gear variable 6, L=2160, 1911-2390, 3 ML	—	1911-2390	K1001-21-N03
2	Corner transmission, 1 ML, 150×150	400-1280	450-2390	K2001-00-N03
2a	Corner transmission, 1 MR, 150×150	400-1280	450-2390	K2005-00-N03
3	Corner transmission, integrated slit, 1 ML, 150×150, left	400-1280	450-2390	K2004-00-L03
	Corner transmission, integrated slit, 1 ML, 150×150, right	400-1280	450-2390	K2004-00-R03
4	Narrow corner transmission, 1 ML, 50×150	300-400	450-2390	K2003-00-N03
		400-600	370-550*	
5b	Stay arm 1, "First Tilt", L=485, 400-600	400-600	—	K3014-05-N03
	Stay arm 2, "First Tilt", L=685, 601-800	601-800	—	K3014-07-N03
	Stay arm 3, "First Tilt", L=915, 801-1040, 1 ML	801-1040	—	K3014-09-N03
	Stay arm 4, "First Tilt", L=1165, 1041-1280, 1 ML	1041-1280	—	K3014-11-N03
6	Middle lock L=400, 1 ML	600-1000	600-1000	K4001-04-N03
	Middle lock L=650, 1 ML	850-1250	850-1250	K4001-06-N03
	Middle lock L=720, 1 ML	920-1320	920-1320	K4001-07-N03
	Middle lock L=820, 1 ML	1251-1430	1251-1430	K4001-08-N03
	Middle lock L=1130, 2 ML	—	1251-1730	K4001-11-N03
6a	Middle lock L=400, 1 MR + 1 ML	600-1000	600-1000	K4008-04-N03
	Middle lock L=650, 1 MR + 1 ML	850-1250	850-1250	K4008-06-N03
	Middle lock L=820, 1 MR + 1 ML	1251-1430	1251-1430	K4008-08-N03
	Middle lock L=1130, 1 MR + 2 ML	—	1251-1730	K4008-11-N03
7	Middle lock extension, 1 ML, 480 mm	—	850-1230	K4005-05-N03
	Middle lock extension, 1 ML, 680 mm	—	1231-1430	K4005-07-N03
10	Locking plate	—	—	***
10a	Locking plate safety	—	—	***
10C	Tilt locking plate "First Tilt", left / right	—	—	***
11	Lifting plate	—	—	***
12	Wrong operation safety device with sash lifter	—	751-2390	A7001-00-N03
13	Corner bearing 3×3	—	—	A5002-00-N03
13a	Corner bearing 6×22	—	—	A5004-00-N03
14	Drill-in corner hinge 3×5	—	—	A5003-00-N03
14a	Drill-in corner hinge with gasket pressure adjustment 6×12	—	—	A5007-00-N03
14b	Drill-in corner hinge with gasket pressure adjustment 6×16/26	—	—	A5006-00-N03
14C	Rebate corner hinge 20/9 left	—	—	A5009-09-L03
	Rebate corner hinge 20/9 right	—	—	A5009-09-R03
	Rebate corner hinge 20/13 left	—	—	A5009-13-L03
	Rebate corner hinge 20/13 right	—	—	A5009-13-R03

Tilt and turn set “First Tilt”

Hardware set combinations

STRAIGHT CUT

Nº	Description	Application range by width	Application range by height	Part No.
15	Stay arm bearing 3x3	—	—	A5001-00-N03
15a	Stay arm bearing 6x24	—	—	A5005-00-N03
16	Top sash hinge	—	—	K5001-**-N03
17	Cover of top sash hinge	—	—	A7004-10-N****
18	Cover of stay arm bearing	—	—	A7005-10-N****
19	Cover of the drill-in corner hinge	—	—	A7006-10-N****
19a	Cover of rebate corner hinge, left / right	—	—	A7009-00-L/R****
20	Top cover of corner bearing	—	—	A7008-10-N****
21	Bottom cover of corner bearing	—	—	A7007-10-N****
26	Extension lock 240 mm, 1 ML	—	—	K4003-02-N03
	Extension lock 480 mm, 1 ML	—	—	K4003-05-N03
27	Locking plate, integrated slit	—	—	***
28	Locking plate for adjustable integrated slit	—	—	***
36	Extension lock for corner transmission 480 mm, 1 ML	—	—	K4010-00-N03
	Extension lock for corner transmission 680 mm, 1 ML	—	—	K4010-07-N03
	Extension lock for corner transmission 880 mm, 2 ML	—	—	K4010-09-N03
	Extension lock for corner transmission 480 mm, 1 MR	—	—	K4030-00-N03

* – displaced from the center

** – according to displacement axis of sash groove (9 mm, 10 mm, 13 mm, 14 mm)

*** – look at the section “Profile-depending elements”

**** – for decorative covers in other colors look at p. 27



Turn set

Hardware set combinations

Turn set, straight cut

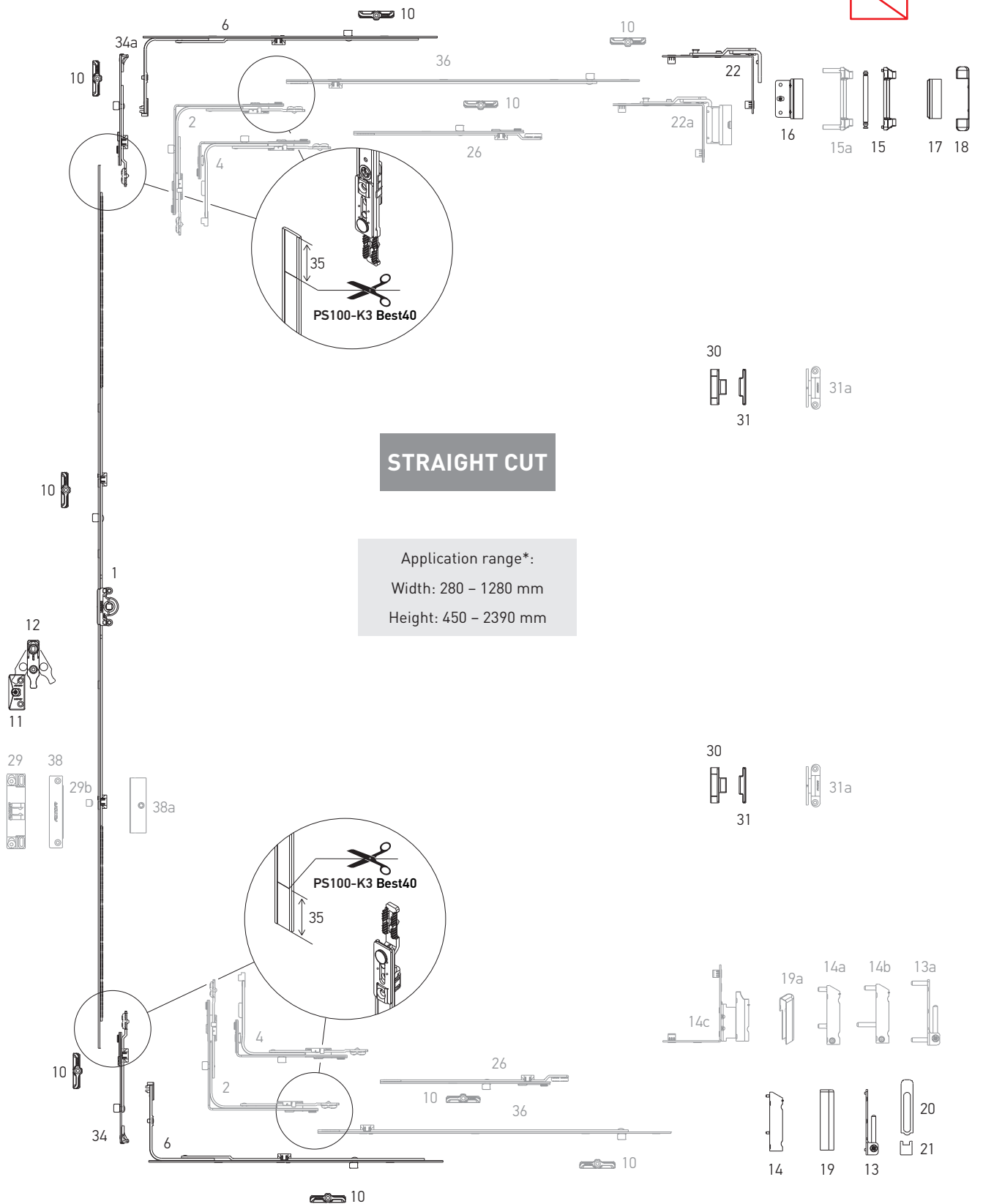
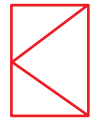

* Use the shoot-bolt 34, 34a

Turn set

Hardware set combinations

STRAIGHT CUT

Nº	Description	Application range by width	Application range by height	Part No.
1	Gear variable 0, L=320, 450-550	—	450-550	K1001-02-N03
	Gear variable 1, L=520, 551-750	—	551-750	K1001-04-N03
	Gear variable 2, L=1000, 751-1230, 1 ML	—	751-1230	K1001-09-N03
	Gear variable 3, L=1200, 950-1430, 1 ML	—	950-1430	K1001-11-N03
	Gear variable 4, L=1480, 1231-1710, 2 ML	—	1231-1710	K1001-14-N03
	Gear variable 5, L=1680, 1431-1910, 2 ML	—	1431-1910	K1001-16-N03
	Gear variable 6, L=2160, 1911-2390, 3 ML	—	1911-2390	K1001-21-N03
2	Corner transmission, 1 ML, 150x150	330-1280	450-2390	K2001-00-N03
4	Narrow corner transmission, 1 ML, 50x150	280-1280	450-2390	K2003-00-N03
		330-520	290-350	
6	Middle lock L=400, 1 ML	600-1000	—	K4001-04-N03
	Middle lock L=650, 1 ML	850-1250	—	K4001-06-N03
10	Locking plate	—	—	***
11	Lifting plate	—	751-2390	***
12	Wrong operation safety device with sash lifter	—	751-2390	A7001-00-N03
13	Corner bearing 3x3	—	—	A5002-00-N03
13a	Corner bearing 6x22	—	—	A5004-00-N03
14	Drill-in corner hinge 3x5	—	—	A5003-00-N03
14a	Drill-in corner hinge with gasket pressure adjustment 6x12	—	—	A5007-00-N03
14b	Drill-in corner hinge with gasket pressure adjustment 6x16/26	—	—	A5006-00-N03
14C	Rebate corner hinge 20/9 left/right	—	—	A5009-09-L/R03
	Rebate corner hinge 20/13 left/right	—	—	A5009-13-L/R03
15	Stay arm bearing 3x3	—	—	A5001-00-N03
15a	Stay arm bearing 6x24	—	—	A5005-00-N03
16	Top sash hinge	—	—	K5001-**-N03
17	Cover of top sash hinge	—	—	A7004-10-N*
18	Cover of stay arm bearing	—	—	A7005-10-N*
19	Cover of the drill-in corner hinge	—	—	A7006-10-N*
19a	Cover of rebate corner hinge, left / right	—	—	A7009-00-L/R*
20	Top cover of corner bearing	—	—	A7008-10-N*
21	Bottom cover of corner bearing	—	—	A7007-10-N*
22	Turn stay arm	—	—	K5002-00-N03
22a	Turn stay arm 12/20-13 left/right	—	—	K5014-13-L/R03
	Turn stay arm 12/20-9 left/right	—	—	K5014-09-L/R03
	Turn stay arm 12/20-13 left/right	—	—	S5001-13-L03/R
	Turn stay arm 12/20-9 left/right	—	—	S5001-09-L03/R
26	Extension lock 240 mm, 1 ML	—	—	K4003-02-N03
	Extension lock 480 mm, 1 ML	—	—	K4003-05-N03
29	Balcony catch	—	—	A7184-13-N03
29b	Balcony locking pin	—	—	A7207-00-N03
30	Concealed middle hinge, sash part	—	—	A7056-00-N03
31	Concealed middle hinge, frame part	—	—	A7057-**-N03

Turn set

Hardware set combinations

STRAIGHT CUT

Nº	Description	Application range by width	Application range by height	Part No.
31a	Middle hinge (white)	—	—	A7185-00-N01
	Middle hinge (brown)	—	—	A7185-00-N02
	Middle hinge (gray anthracite)	—	—	A7185-00-N09
34	Bottom extension for turn sash 90°	—	—	K4007-00-N03
34a	Bottom extension for turn sash 180°	—	—	K4011-00-N03
36	Extension lock for corner transmission 480 mm, 1 ML	—	—	K4010-00-N03
	Extension lock for corner transmission 680 mm, 1 ML	—	—	K4010-07-N03
	Extension lock for corner transmission 880 mm, 2 ML	—	—	K4010-09-N03
	Extension lock for corner transmission 480 mm, 1 MR	—	—	K4030-00-N03
38	Magnetic balcony catch, frame part	—	—	A7053-00-N03
38a	Magnetic balcony catch, sash part	—	—	A7055-**-N03

* – for decorative covers in other colors look at p. 27

** – according to displacement axis of sash groove (9 mm, 10 mm, 13 mm, 14 mm)

*** – look at the section "Profile-dependent elements"

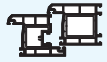

Turn set

Hardware set combinations

Turn set

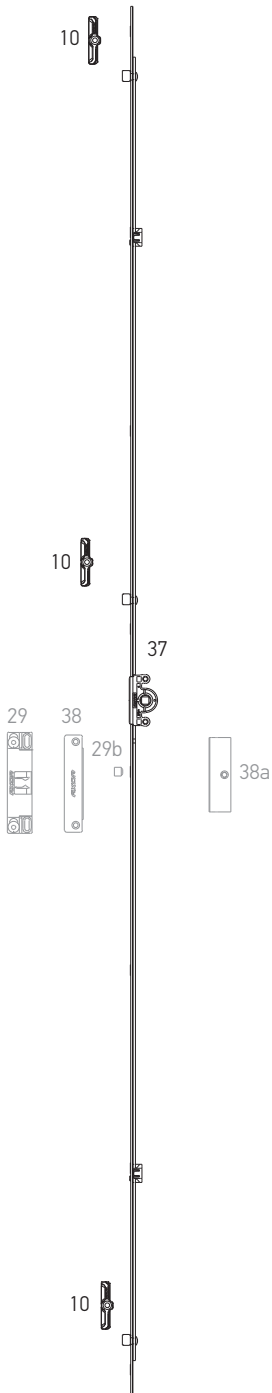

STRAIGHT CUT

Application range:
Width: 280 – 700 mm
Height: 300 – 2400 mm

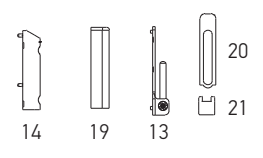
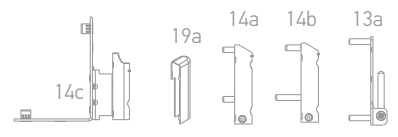
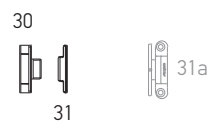
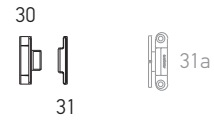
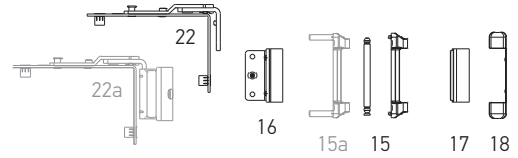



Turn set

STRAIGHT CUT

Hardware set combinations

Nº	Description	Application range by width	Application range by height	Part No.
10	Locking plate	—	—	***
13	Corner bearing 3x3	—	—	A5002-00-N03
13a	Corner bearing 6x22	—	—	A5004-00-N03
14	Drill-in corner hinge 3x5	—	—	A5003-00-N03
14a	Drill-in corner hinge with gasket pressure adjustment 6x12	—	—	A5007-00-N03
14b	Drill-in corner hinge with gasket pressure adjustment 6x12/26	—	—	A5006-00-N03
14C	Rebate corner hinge 20/9 left	—	—	A5009-09-L03
	Rebate corner hinge 20/9 right	—	—	A5009-09-R03
	Rebate corner hinge 20/13 left	—	—	A5009-13-L03
	Rebate corner hinge 20/13 right	—	—	A5009-13-R03
15	Stay arm bearing 3x3	—	—	A5001-00-N03
15a	Stay arm bearing 6x24	—	—	A5005-00-N03
16	Top sash hinge	—	—	K5001-**-N03
17	Cover of top sash hinge	—	—	A7004-10-N*
18	Cover of stay arm bearing	—	—	A7005-10-N*
19	Cover of the drill-in corner hinge	—	—	A7006-10-N*
19a	Cover of rebate corner hinge, left / right	—	—	A7009-00-L/R*
20	Top cover of corner bearing	—	—	A7008-10-N*
21	Bottom cover of corner bearing	—	—	A7007-10-N*
22	Turn stay arm	—	—	K5002-00-N03
22a	Turn stay arm 12/20-13 left/right	—	—	K5014-13-L/R03
	Turn stay arm 12/20-9 left/right	—	—	K5014-09-L/R03
	Turn stay arm 12/20-13 left/right	—	—	S5001-13-L03/R
	Turn stay arm 12/20-9 left/right	—	—	S5001-09-L03/R
29	Balcony catch	—	—	A7184-13-N03
29b	Balcony locking pin	—	—	A7207-00-N03
30	Concealed middle hinge, sash part	—	—	A7056-00-N03
31	Concealed middle hinge, frame part	—	—	A7057-**-N03
31a	Middle hinge (white)	—	—	A7185-00-N01
	Middle hinge (brown)	—	—	A7185-00-N02
	Middle hinge (gray anthracite)	—	—	A7185-00-N09
37	Gear variable 1 L=300, 300 - 500, 2 ML	280-700	300-500	K1003-03-N03
	Gear variable 2 L=400, 401 - 600, 2 ML		401-600	K1003-04-N03
	Gear variable 3 L=600, 601 - 800, 2 ML		601-800	K1003-06-N03
	Gear variable 4 L=800, 801 - 1000, 2 ML		801-1000	K1003-08-N03
	Gear variable 5 L=1000, 1001 - 1200, 3 ML		1001-1200	K1003-10-N03
	Gear variable 6 L=1200, 1201 - 1400, 3 ML		1201-1400	K1003-12-N03
	Gear variable 7 L=1400, 1401 - 1600, 3 ML		1401-1600	K1003-14-N03
	Gear variable 8 L=1600, 1601 - 1800, 4ML		1601-1800	K1003-16-N03
	Gear variable 9 L=1800, 1801 - 2000, 4ML		1801-2000	K1003-18-N03
	Gear variable 10 L=2000, 2001 - 2200, 4ML		2001-2200	K1003-20-N03
Gear variable 11 L=2200, 2201 - 2400, 4ML	2201-2400	K1003-22-N03		
38	Magnetic balcony catch, frame part	—	—	A7053-00-N03
38a	Magnetic balcony catch, sash part	—	—	A7055-**-N03

* – for decorative covers in other colors look at p. 27

** – according to displacement axis of sash groove (9 mm, 10 mm, 13 mm, 14 mm)

*** – look at the section "Profile-dependent elements"



Tilt set

Hardware set combinations

Tilt set, straight cut.

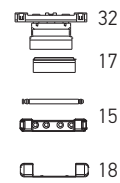
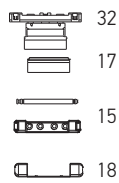
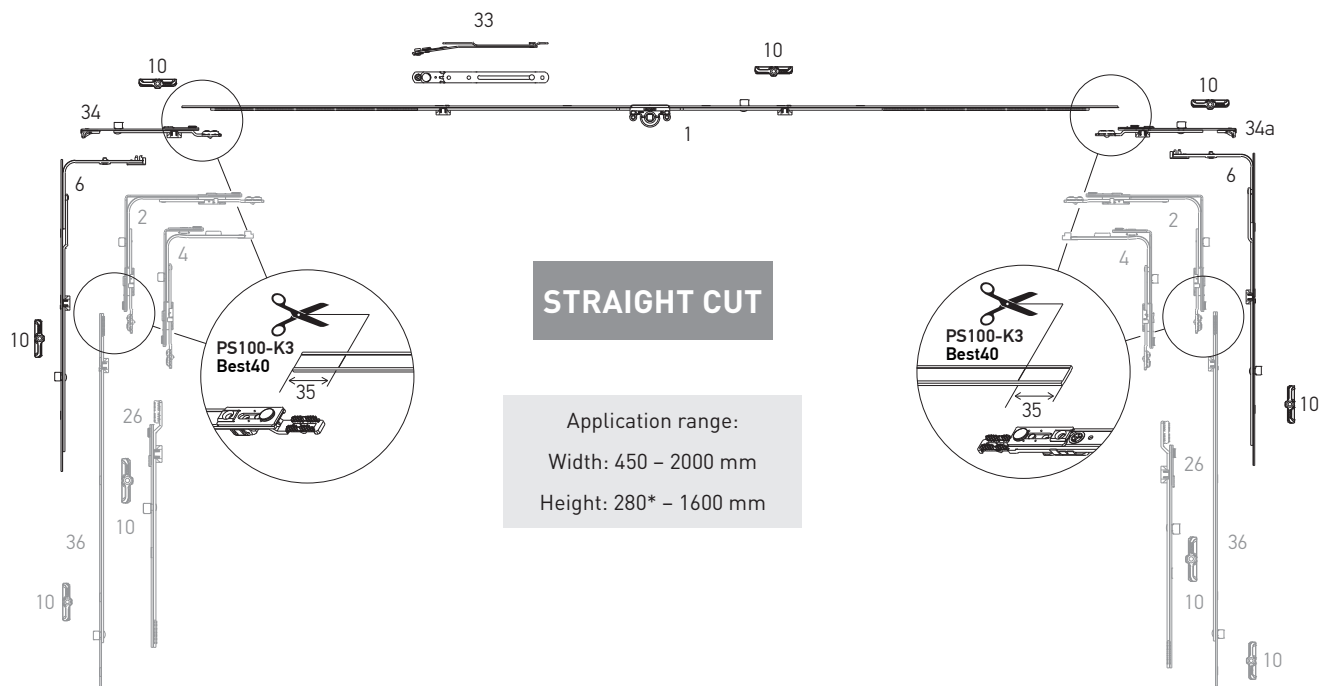
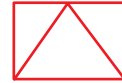

* without middle lock



Tilt set

Hardware set combinations

STRAIGHT CUT

Nº	Description	Application range by width	Application range by height	Part No.
1	Gear variable 0, L=320, 450-550	—	450-550	K1001-02-N03
	Gear variable 1, L=520, 551-750	—	551-750	K1001-04-N03
	Gear variable 2, L=1000, 751-1230, 1 ML	—	751-1230	K1001-09-N03
	Gear variable 3, L=1200, 950-1430, 1 ML	—	950-1430	K1001-11-N03
	Gear variable 4, L=1480, 1231-1710, 2 ML	—	1231-1710	K1001-14-N03
	Gear variable 5, L=1680, 1431-1910, 2 ML	—	1431-1910	K1001-16-N03
	Gear variable 6, L=2160, 1911-2390, 3 ML	—	1911-2390	K1001-21-N03
2	Corner transmission, 1 ML, 150×150	330-1280	450-2390	K2001-00-N03
4	Narrow corner transmission, 1 ML, 50×150	280-1280	450-2390	K2003-00-N03
		330-520	290-350	
6	Middle lock L=400, 1 ML	—	600-1000	K4001-04-N03
	Middle lock L=650, 1 ML	—	850-1250	K4001-06-N03
	Middle lock L=720, 1 ML	—	920-1320	K4001-07-N03
	Middle lock L=820, 1 ML	—	1251-1430	K4001-08-N03
	Middle lock L=1130, 2 ML	—	1251-1730	K4001-11-N03
10	Locking plate	—	—	***
15	Stay arm bearing 3x3	—	—	A5001-00-N03
17	Cover of top sash hinge	—	—	A7004-10-N*
18	Cover of stay arm bearing	—	—	A7005-10-N*
26	Extension lock 240 mm, 1 ML	—	—	K4003-02-N03
	Extension lock 480 mm, 1 ML	—	—	K4003-05-N03
30	Concealed middle hinge, sash part	—	—	A7056-00-N03
31	Concealed middle hinge, frame part	—	—	A7057-**-N03
31a	Middle hinge (white)	—	—	A7185-00-N01
	Middle hinge (brown)	—	—	A7185-00-N02
	Middle hinge (gray anthracite)	—	—	A7185-00-N09
32	Bottom hinges for tilt sash	—	—	A7014-**-N03
33	Tilt stay arm	—	—	A7107-00-N03
	Tilt stay arm	—	—	A7017-00-N03
34	Bottom extension for turn sash 90°	—	—	K4007-00-N03
34a	Bottom extension for turn sash 180°	—	—	K4011-00-N03
36	Extension lock for corner transmission 480 mm, 1 ML	—	—	K4010-00-N03
	Extension lock for corner transmission 680 mm, 1 ML	—	—	K4010-07-N03
	Extension lock for corner transmission 880 mm, 2 ML	—	—	K4010-09-N03
	Extension lock for corner transmission 480 mm, 1 MR	—	—	K4030-00-N03

* – for decorative covers in other colors look at p. 27

** – according to displacement axis of sash groove [9 mm, 10 mm, 13 mm, 14 mm]

*** – look at the section "Profile-dependent elements"



Tilt set

Hardware set combinations

Tilt set

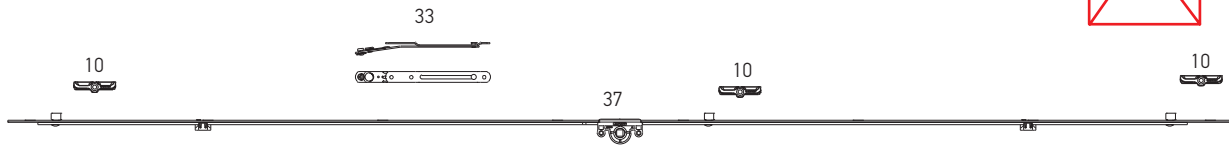
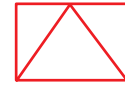

STRAIGHT CUT

Application range:
Width: 300 – 2000 mm
Height: 280 – 700 mm

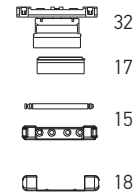
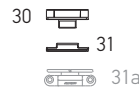
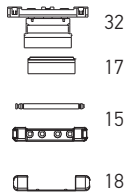

Nº	Description	Application range by width	Application range by height	Part No.
10	Locking plate	—	—	***
15	Stay arm bearing 3x3	—	—	A5001-00-N03
17	Cover of top sash hinge	—	—	A7004-10-N*
18	Cover of stay arm bearing	—	—	A7005-10-N*
30	Concealed middle hinge, sash part	—	—	A7056-00-N03
31	Concealed middle hinge, frame part	—	—	A7057-**-N03
31a	Middle hinge (white)	—	—	A7185-00-N01
	Middle hinge (brown)	—	—	A7185-00-N02
	Middle hinge (gray anthracite)	—	—	A7185-00-N09
32	Bottom hinges for tilt sash	—	—	A7014-**-N03
33	Tilt stay arm	—	—	A7107-00-N03
	Tilt stay arm	—	—	A7017-00-N03
37	Gear variable 1 L=300, 300 - 500, 2 ML	300-500	280-700	K1003-03-N03
	Gear variable 2 L=400, 401 - 600, 2 ML	401-600		K1003-04-N03
	Gear variable 3 L=600, 601 - 800, 2 ML	601-800		K1003-06-N03
	Gear variable 4 L=800, 801 - 1000, 2 ML	801-1000		K1003-08-N03
	Gear variable 5 L=1000, 1001 - 1200, 3 ML	1001-1200		K1003-10-N03
	Gear variable 6 L=1200, 1201 - 1400, 3 ML	1201-1400		K1003-12-N03
	Gear variable 7 L=1400, 1401 - 1600, 3 ML	1401-1600		K1003-14-N03
	Gear variable 8 L=1600, 1601 - 1800, 4ML	1601-1800		K1003-16-N03
Gear variable 9 L=1800, 1801 - 2000, 4ML	1801-2000	K1003-18-N03		

* – for decorative covers in other colors look at p. 27

** – according to displacement axis of sash groove (9 mm, 10 mm, 13 mm, 14 mm)

*** – look at the section "Profile-dependent elements"

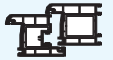

Double sash set, straight cut

Hardware set combinations

Secondary sash of double-sash window

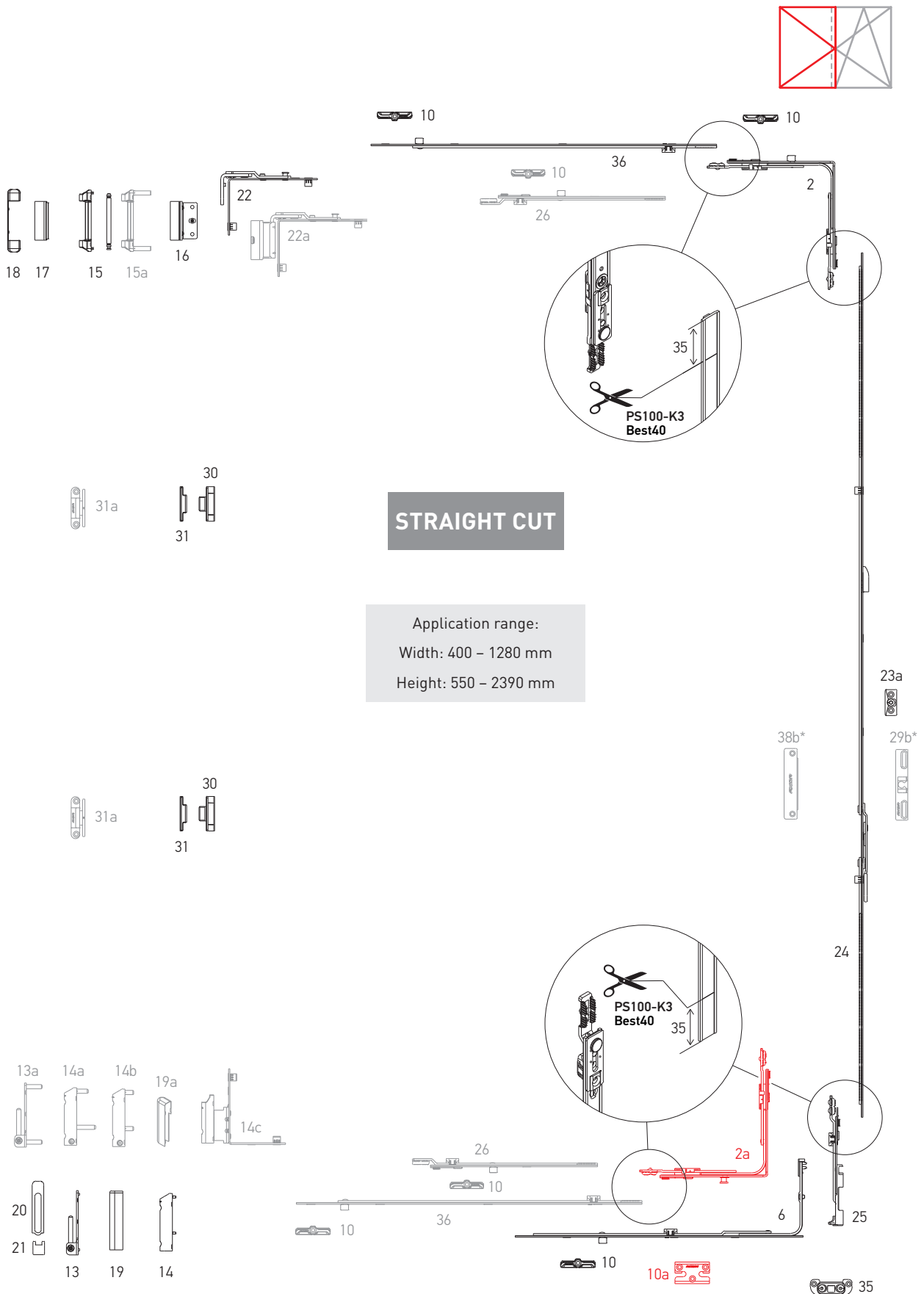

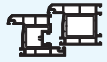

Double sash set, straight cut

Hardware set combinations

Main sash

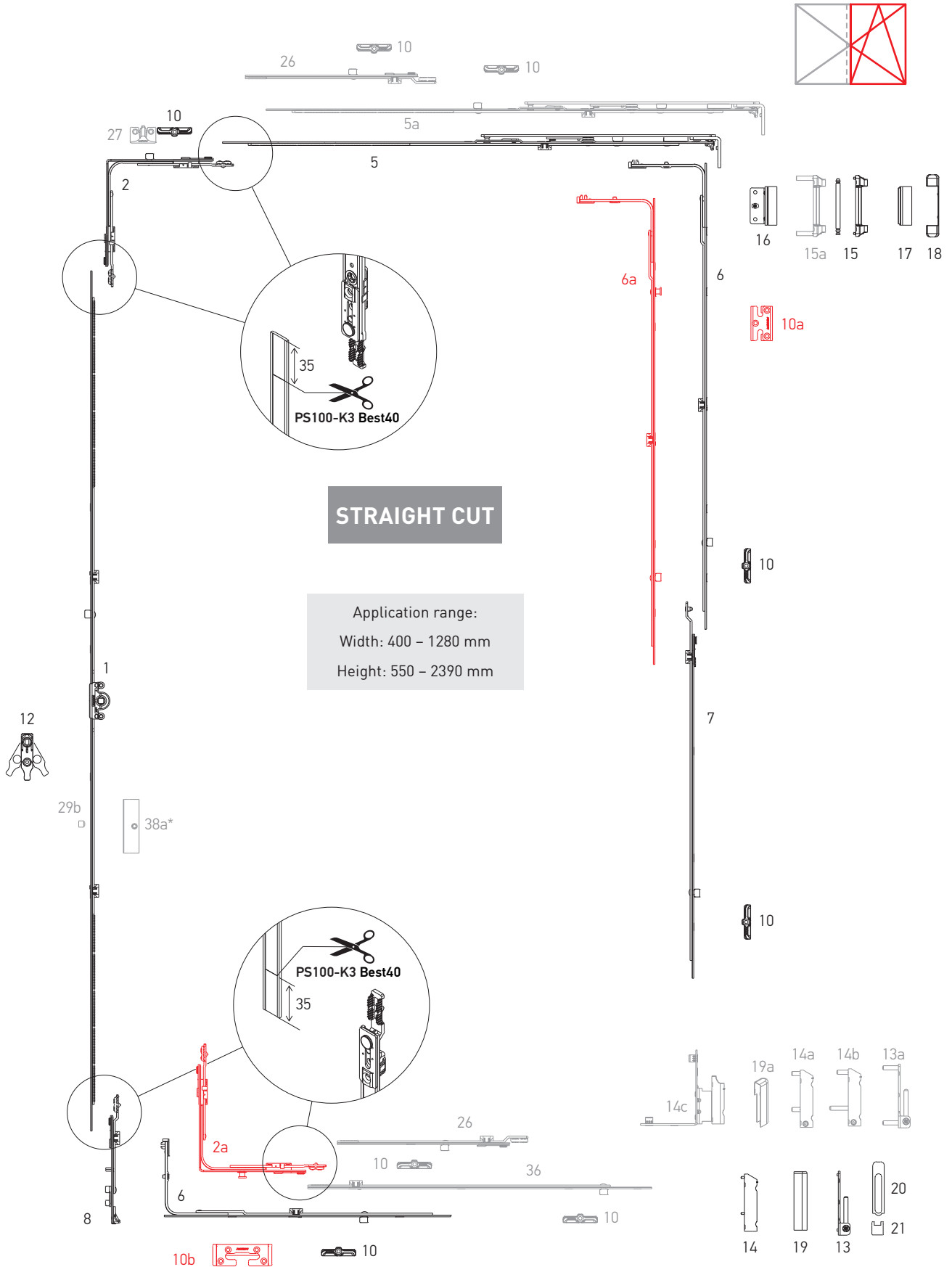

STRAIGHT CUT

Application range:
Width: 400 - 1280 mm
Height: 550 - 2390 mm

* - only with gear K1002-21-N03



Double sash set

Hardware set combinations

STRAIGHT CUT

Nº	Description	Application range by width	Application range by height	Part No.
1	Gear variable 1, L=520, 551-750	—	551-750	K1001-04-N03
	Gear variable 2, L=1000, 751-1230, 1 ML	—	751-1230	K1001-09-N03
	Gear variable 3, L=1200, 950-1430, 1 ML	—	950-1430	K1001-11-N03
	Gear variable 5, L=1680, 1431-1910, 2 ML	—	1431-1910	K1001-16-N03
	Gear variable 6, L=2160, 1911-2390, 3 ML	—	1911-2390	K1001-21-N03
2	Corner transmission, 1 ML, 150×150	400-1280	450-2390	K2001-00-N03
2a	Corner transmission, 1 MR, 150×150	400-1280	450-2390	K2005-00-N03
5	Stay arm 1, L=485, 400-600	400-600	—	K3001-05-N03
	Stay arm 2, L=685, 601-800	601-800	—	K3001-07-N03
	Stay arm 3, L=925, 801-1040, 1 ML	801-1040	—	K3001-09-N03
	Stay arm 4, L=1165, 1041-1280, 1 ML	1041-1280	—	K3001-11-N03
5a	Stay arm 2, L=685, 601-800, 1 ML	601-800	—	K3001-57-N03
6	Middle lock L=400, 1 ML	600-1000	600-1000	K4001-04-N03
	Middle lock L=650, 1 ML	850-1250	850-1250	K4001-06-N03
	Middle lock L=720, 1 ML	920-1320	920-1320	K4001-07-N03
	Middle lock L=820, 1 ML	1251-1430	1251-1430	K4001-08-N03
	Middle lock L=1130, 2 ML	—	1251-1730	K4001-11-N03
6a	Middle lock L=400, 1 MR + 1 ML	600-1000	600-1000	K4008-04-N03
	Middle lock L=650, 1 MR + 1 ML	850-1250	850-1250	K4008-06-N03
	Middle lock L=820, 1 MR + 1 ML	1251-1430	1251-1430	K4008-08-N03
	Middle lock L=1130, 1 MR + 2 ML	—	1251-1730	K4008-11-N03
7	Middle lock extension, 1 ML, 480 mm	—	1710-2210	K4005-05-N03
	Middle lock extension, 1 ML, 680 mm	—	2231-2390	K4005-07-N03
8	Bottom extension	—	450-800	K4009-00-N03
		—	801-2390	K4002-00-N03
10	Locking plate	—	—	***
10a	Locking plate safety	—	—	***
10b	Tilt locking plate safety	—	—	***
12	Wrong operation safety device with sash lifter	—	751-2390	A7001-00-N03
13	Corner bearing 3x3	—	—	A5002-00-N03
13a	Corner bearing 6x22	—	—	A5004-00-N03
14	Drill-in corner hinge 3x5	—	—	A5003-00-N03
14a	Drill-in corner hinge with gasket pressure adjustment 6×12	—	—	A5006-00-N03
14b	Drill-in corner hinge with gasket pressure adjustment 6×16/26	—	—	A5007-00-N03
14C	Rebate corner hinge 20/9 left	—	—	A5009-09-L03
	Rebate corner hinge 20/9 right	—	—	A5009-09-R03
	Rebate corner hinge 20/13 left	—	—	A5009-13-L03
	Rebate corner hinge 20/13 right	—	—	A5009-13-R03
15	Stay arm bearing 3x3	—	—	A5001-00-N03
15a	Stay arm bearing 6x24	—	—	A5005-00-N03
16	Top sash hinge	—	—	K5001-**-N03
17	Cover of top sash hinge	—	—	A7004-10-N*

Double sash set

Hardware set combinations

STRAIGHT CUT

Nº	Description	Application range by width	Application range by height	Part No.
18	Cover of stay arm bearing	—	—	A7005-10-N*
19	Cover of the drill-in corner hinge	—	—	A7006-10-N*
19a	Cover of rebate corner hinge, left / right	—	—	A7009-00-L/R*
20	Top cover of corner bearing	—	—	A7008-10-N*
21	Bottom cover of corner bearing	—	—	A7007-10-N*
22	Turn stay arm	—	—	K5002-00-N03
22a	Turn stay arm 12/20-13 left/right	—	—	K5014-13-L/R03
	Turn stay arm 12/20-9 left/right	—	—	K5014-09-L/R03
	Turn stay arm 12/20-13 left/right	—	—	S5001-13-L03/R
	Turn stay arm 12/20-9 left/right	—	—	S5001-09-L03/R
23a	Lifting plate plate for double-sash window	—	—	A6001-00-N03
24	Double-sash gear 1 L=520, 551-750	—	551-750	K1002-04-N03
	Double-sash gear 2 L=720, 751-950	—	751-950	K1002-06-N03
	Double-sash gear 3 L=1200, 951-1430	—	951-1430	K1002-11-N03
	Double-sash gear 4 L=1680, 1431-1910	—	1431-1910	K1002-16-N03
	Double-sash gear 5 L=2160, 1911-2390	—	1911-2390	K1002-21-N03
25	Shoot bolt (bottom)	—	—	K4006-00-N03
26	Extension lock 240 mm, 1 ML	—	—	K4003-02-N03
	Extension lock 480 mm, 1 ML	—	—	K4003-05-N03
27	Locking plate, integrated slit	—	—	***
29a	Balcony catch for double-sash gear	—	1911-2390	A7047-00-N03
29b	Balcony locking pin	—	—	A7207-00-N03
30	Concealed middle hinge, sash part	—	—	A7056-00-N03
31	Concealed middle hinge, frame part	—	—	A7057-**-N03
31a	Middle hinge (white)	—	—	A7185-00-N01
	Middle hinge (brown)	—	—	A7185-00-N02
	Middle hinge (gray anthracite)	—	—	A7185-00-N09
35	Locking plate adjustable for shoot bolt	—	—	***
36	Extension lock for corner transmission 480 mm, 1 ML	—	—	K4010-00-N03
	Extension lock for corner transmission 680 mm, 1 ML	—	—	K4010-07-N03
	Extension lock for corner transmission 880 mm, 2 ML	—	—	K4010-09-N03
	Extension lock for corner transmission 480 mm, 1 MR	—	—	K4030-00-N03
38a	Magnetic balcony catch, sash part	—	—	A7055-**-N03
38b	Magnetic balcony catch for double-sash gear, frame part	—	—	A7054-00-N03

* – for decorative covers in other colors look at p. 27

** – according to displacement axis of sash groove (9 mm, 10 mm, 13 mm, 14 mm)

*** – look at the section "Profile-depending elements"



Double sash set "First Tilt", straight cut

Hardware set combinations

Secondary sash of double-sash window "First Tilt"

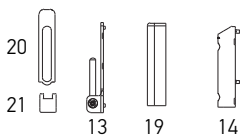
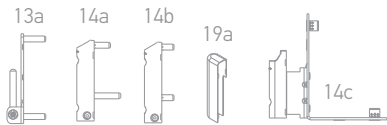
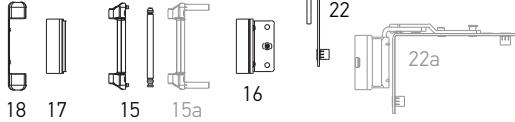
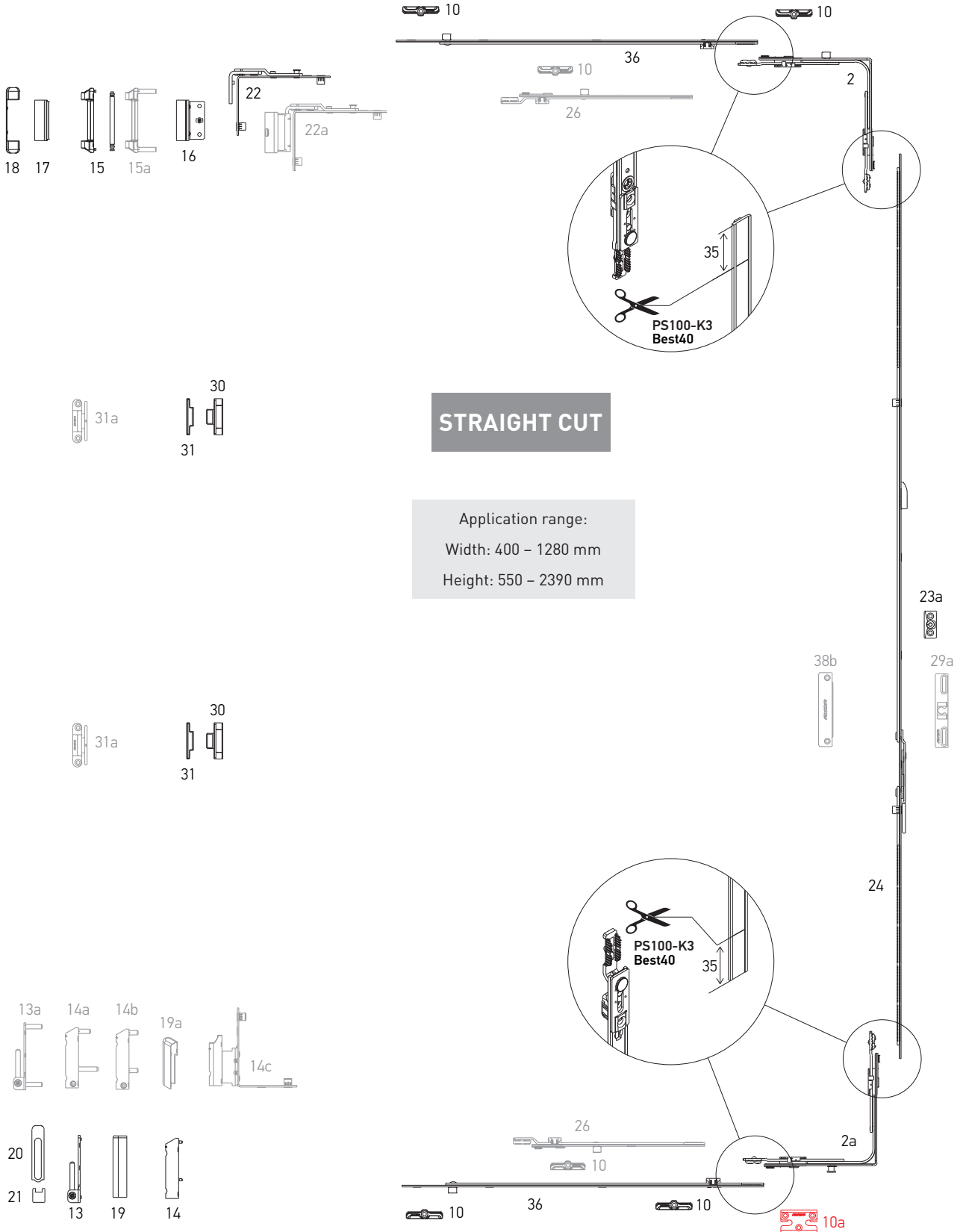
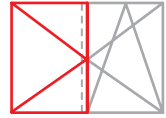

STRAIGHT CUT

Application range:
Width: 400 – 1280 mm
Height: 550 – 2390 mm



Double sash set "First Tilt", straight cut

Hardware set combinations

Main sash "First Tilt"

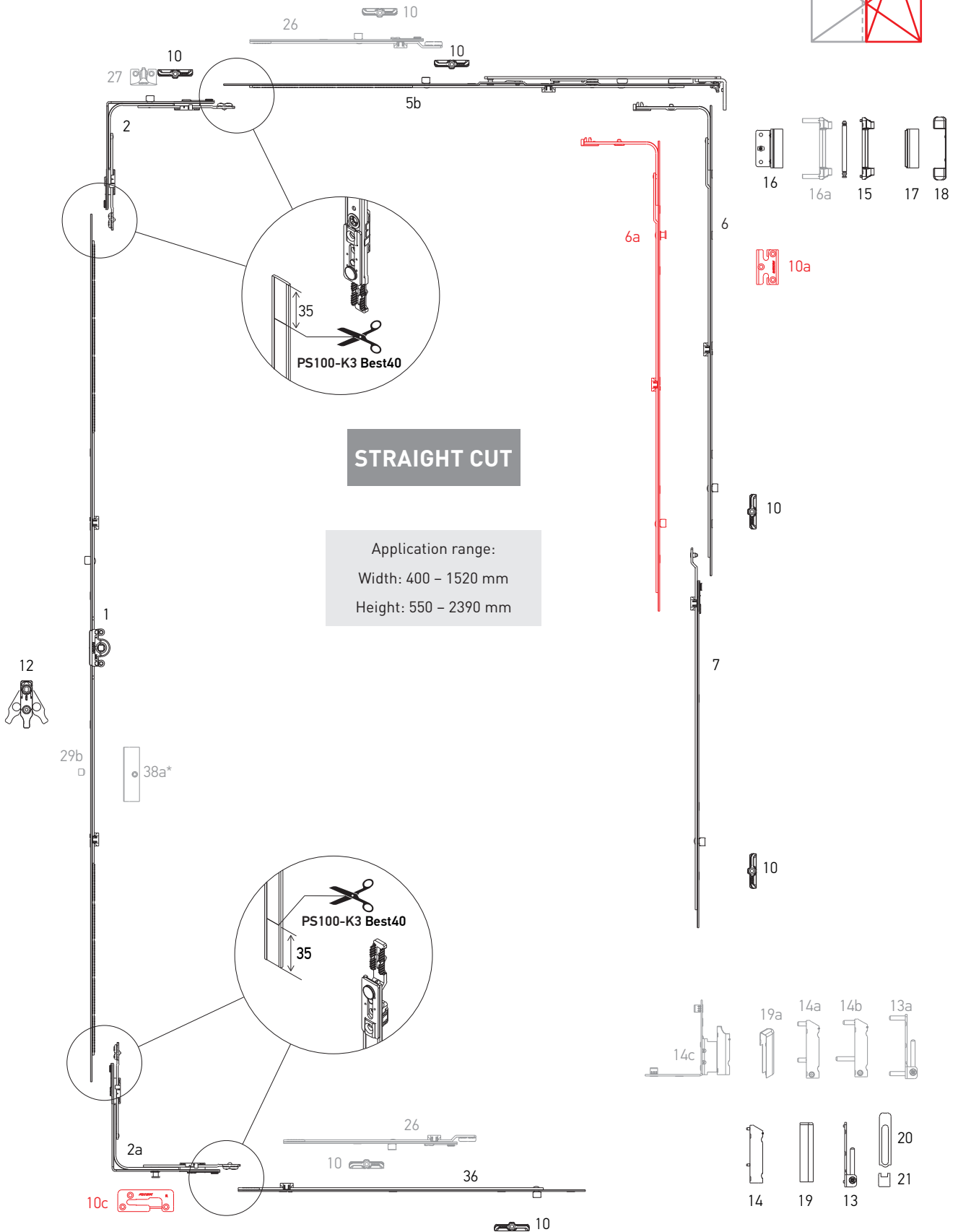
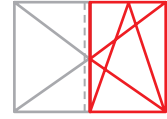

STRAIGHT CUT

Application range:
Width: 400 - 1520 mm
Height: 550 - 2390 mm

* - only with gear K1002-21-N03



Double sash set "First Tilt"

STRAIGHT CUT

Hardware set combinations

Nº	Description	Application range by width	Application range by height	Part No.
1	Gear variable 1, L=520, 551-750	—	551-750	K1001-04-N03
	Gear variable 2, L=1000, 751-1230, 1 ML	—	751-1230	K1001-09-N03
	Gear variable 3, L=1200, 950-1430, 1 ML	—	950-1430	K1001-11-N03
	Gear variable 5, L=1680, 1431-1910, 2 ML	—	1431-1910	K1001-16-N03
	Gear variable 6, L=2160, 1911-2390, 3 ML	—	1911-2390	K1001-21-N03
2	Corner transmission, 1 ML, 150×150	400-1280	450-2390	K2001-00-N03
2a	Corner transmission, 1 MR, 150×150	400-1280	450-2390	K2005-00-N03
5b	Stay arm 1, "First Tilt", L=485, 400-600	400-600	—	K3014-05-N03
	Stay arm 2, "First Tilt", L=685, 601-800	601-800	—	K3014-07-N03
	Stay arm 3, "First Tilt", L=915, 801-1040, 1 ML	801-1040	—	K3014-09-N03
	Stay arm 4, "First Tilt", L=1165, 1041-1280, 1 ML	1041-1280	—	K3014-11-N03
6	Middle lock L=400, 1 ML	—	600-1000	K4001-04-N03
	Middle lock L=650, 1 ML	—	850-1250	K4001-06-N03
	Middle lock L=720, 1 ML	—	920-1320	K4001-07-N03
	Middle lock L=820, 1 ML	—	1251-1430	K4001-08-N03
	Middle lock L=1130, 2 ML	—	1251-1730	K4001-11-N03
6a	Middle lock L=400, 1 MR + 1 ML	—	600-1000	K4008-04-N03
	Middle lock L=650, 1 MR + 1 ML	—	850-1250	K4008-06-N03
	Middle lock L=820, 1 MR + 1 ML	—	1251-1430	K4008-08-N03
	Middle lock L=1130, 1 MR + 2 ML	—	1251-1730	K4008-11-N03
7	Middle lock extension, 1 ML, 480 mm	—	850-1230	K4005-05-N03
	Middle lock extension, 1 ML, 680 mm	—	1231-1430	K4005-07-N03
10	Locking plate	—	—	***
10a	Locking plate safety	—	—	***
10C	Tilt locking plate "First Tilt", left/right	—	—	***
12	Wrong operation safety device with sash lifter	—	751-2390	A7001-00-N03
13	Corner bearing 3×3	—	—	A5002-00-N03
13a	Corner bearing 6×22	—	—	A5004-00-N03
14	Drill-in corner hinge 3×5	—	—	A5003-00-N03
14a	Drill-in corner hinge with gasket pressure adjustment 6×12	—	—	A5006-00-N03
14b	Drill-in corner hinge with gasket pressure adjustment 6×16/26	—	—	A5007-00-N03
14C	Rebate corner hinge 20/9 left	—	—	A5009-09-L03
	Rebate corner hinge 20/9 right	—	—	A5009-09-R03
	Rebate corner hinge 20/13 left	—	—	A5009-13-L03
	Rebate corner hinge 20/13 right	—	—	A5009-13-R03
15	Stay arm bearing 3×3	—	—	A5001-00-N03
15a	Stay arm bearing 6×24	—	—	A5005-00-N03
16	Top sash hinge	—	—	***
17	Cover of top sash hinge	—	—	A7004-10-N*
18	Cover of stay arm bearing	—	—	A7005-10-N*

Double sash set “First Tilt”

Hardware set combinations

STRAIGHT CUT

Nº	Description	Application range by width	Application range by height	Part No.
19	Cover of the drill-in corner hinge	—	—	A7006-10-N*
19a	Cover of rebate corner hinge, left / right	—	—	A7009-00-L/R*
20	Top cover of corner bearing	—	—	A7008-10-N*
21	Bottom cover of corner bearing	—	—	A7007-10-N*
22	Turn stay arm	—	—	K5002-00-N03
22a	Turn stay arm 12/20-13 left/right	—	—	K5014-13-L/R03
	Turn stay arm 12/20-9 left/right	—	—	K5014-09-L/R03
	Turn stay arm 12/20-13 left/right	—	—	S5001-13-L03/R
	Turn stay arm 12/20-9 left/right	—	—	S5001-09-L03/R
23a	Lifting plate plate for double-sash window	—	—	***
24	Double-sash gear 1 L=520, 551-750	—	551-750	K1002-04-N03
	Double-sash gear 2 L=720, 751-950	—	751-950	K1002-06-N03
	Double-sash gear 3 L=1200, 951-1430	—	951-1430	K1002-11-N03
	Double-sash gear 4 L=1680, 1431-1910	—	1431-1910	K1002-16-N03
	Double-sash gear 5 L=2160, 1911-2390	—	1911-2390	K1002-21-N03
26	Extension lock 240 mm, 1 ML	—	—	K4003-02-N03
	Extension lock 480 mm, 1 ML	—	—	K4003-05-N03
27	Locking plate, integrated slit	—	—	***
29a	Balcony catch for double-sash gear	—	1911-2390	A7047-00-N03
29b	Balcony locking pin	—	—	A7207-00-N03
30	Concealed middle hinge, sash part	—	—	A7056-00-N03
31	Concealed middle hinge, frame part	—	—	A7057-**-N03
31a	Middle hinge (white)	—	—	A7185-00-N01
	Middle hinge (brown)	—	—	A7185-00-N02
	Middle hinge (gray anthracite)	—	—	A7185-00-N09
36	Extension lock for corner transmission 480 mm, 1 ML	—	—	K4010-00-N03
	Extension lock for corner transmission 680 mm, 1 ML	—	—	K4010-07-N03
	Extension lock for corner transmission 880 mm, 2 ML	—	—	K4010-09-N03
	Extension lock for corner transmission 480 mm, 1 MR	—	—	K4030-00-N03
38a	Magnetic balcony catch, sash part	—	—	A7055-**-N03
38b	Magnetic balcony catch for double-sash gear	—	—	A7054-13-N03

* – for decorative covers in other colors look at p. 27

** – according to displacement axis of sash groove (9 mm, 10 mm, 13 mm, 14 mm)

*** – look at the section “Profile-dependent elements”

Tilt and turn set

Hardware set combinations

Tilt and turn set, eccentric cut.

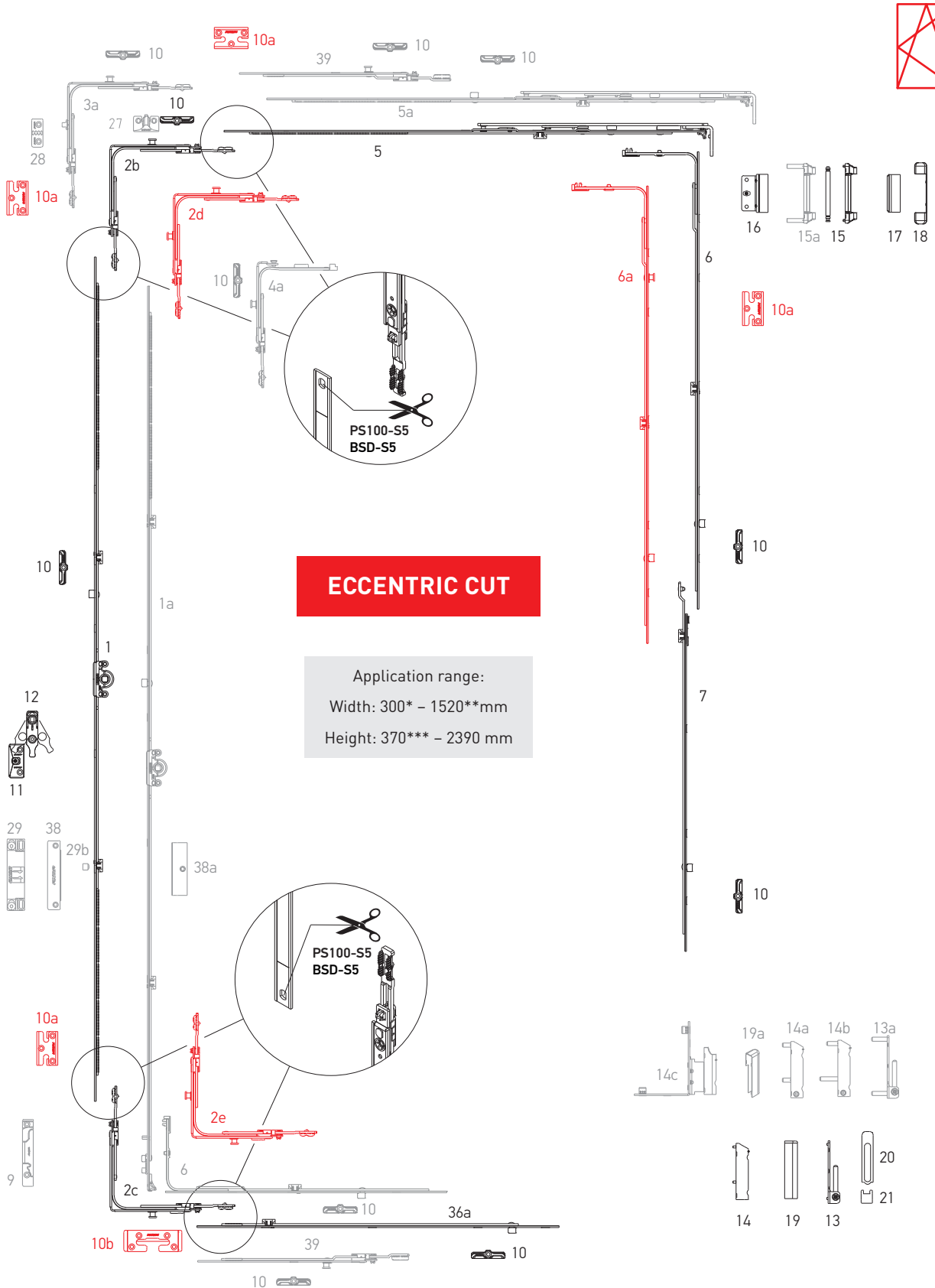

* with narrow corner transmission
 ** with the linear extension 240 mm
 *** with the constant gear K1004-04-N03



Tilt and turn set

ECCENTRIC CUT

Hardware set combinations

Nº	Description	Application range by width	Application range by height	Part No.
1	Gear variable 0, L=320, 450-550	—	450-550	K1001-02-N03
	Gear variable 1, L=520, 551-750	—	551-750	K1001-04-N03
	Gear variable 2, L=1000, 751-1230, 1 ML	—	751-1230	K1001-09-N03
	Gear variable 3, L=1200, 950-1430, 1 ML	—	950-1430	K1001-11-N03
	Gear variable 4, L=1480, 1231-1710, 2 ML	—	1231-1710	K1001-14-N03
	Gear variable 5, L=1680, 1431-1910, 2 ML	—	1431-1910	K1001-16-N03
	Gear variable 6, L=2160, 1911-2390, 3 ML	—	1911-2390	K1001-21-N03
1a	Constant gear 0, L=435, G=140, 370-550*	—	370-550	K1004-04-N03
	Constant gear 1, L=385, G=175, 400-500*	—	400-500	K1004-03-N03
	Constant gear 2, L=565, G=200, 480-680*	—	480-680	K1004-05-N03
	Constant gear 3, L=805, G=300, 681-920*, 1 ML	—	681-920	K1004-08-N03
	Constant gear 4, L=1045, G=450, 921-1160*, 1 ML	—	921-1160	K1004-10-N03
	Constant gear 5, L=1285, G=600, 1161-1400*, 1 ML	—	1161-1400	K1004-12-N03
	Constant gear 6, L=1525, G=600, 1401-1640*, 2 ML	—	1401-1640	K1004-15-N03
	Constant gear 7, L=1765, G=600, 1641-1880*, 2 ML	—	1641-1880	K1004-17-N03
	Constant gear 8, L=1765, G=1000, 1641-1880*, 2 ML	—	1641-1880	K1004-18-N03
	Constant gear 9, L=2005, G=1000, 1881-2120*, 2 ML	—	1881-2120	K1004-20-N03
	Constant gear 10, L=2245, G=1000, 2121-2360*, 3 ML	—	2121-2360	K1004-22-N03
2b	Corner transmission, 1 MR, 115×115	400-1280	450-2390	K2025-00-N03
2c	Corner transmission, bottom, 1 MR, 115×115	400-1280	450-2390	K2028-00-N03
2d	Corner transmission, 2 MR, 115×115	400-1280	450-2390	K2032-00-N03
2e	Corner transmission, bottom, 2 MR, 115×115	400-1280	450-2390	K2029-00-N03
3a	Corner transmission, integrated slit, 1 MR, left/right, 115×115	400-1280	450-2390	K2034-00-L/R03
4a	Narrow corner transmission, 1 MR, 115×115	300-400	450-2390	K2026-00-N03
		400-600	370-550*	
5	Stay arm 1, L=485, 400-600	400-600	—	K3001-05-N03
	Stay arm 2, L=685, 601-800	601-800	—	K3001-07-N03
	Stay arm 3, L=925, 801-1040, 1 ML	801-1040	—	K3001-09-N03
	Stay arm 4, L=1165, 1041-1280, 1 ML	1041-1280	—	K3001-11-N03
5a	Stay arm 2, L=685, 601-800, 1 ML	601-800	—	K3001-57-N03
6	Middle lock L=400, 1 ML	600-1000	600-1000	K4001-04-N03
	Middle lock L=650, 1 ML	850-1250	850-1250	K4001-06-N03
	Middle lock L=720, 1 ML	920-1320	920-1320	K4001-07-N03
	Middle lock L=820, 1 ML	1251-1430	1251-1430	K4001-08-N03
	Middle lock L=1130, 2 ML	—	1251-1730	K4001-11-N03
6a	Middle lock L=400, 1 MR + 1 ML	600-1000	600-1000	K4008-04-N03
	Middle lock L=650, 1 MR + 1 ML	850-1250	850-1250	K4008-06-N03
	Middle lock L=820, 1 MR + 1 ML	1251-1430	1251-1430	K4008-08-N03
	Middle lock L=1130, 1 MR + 2 ML	—	1251-1730	K4008-11-N03
7	Middle lock extension, 1 ML, 480 mm	—	1710-2210	K4005-05-N03
	Middle lock extension, 1 ML, 680 mm	—	2211-2390	K4005-07-N03
9	Tilt locking plate, right / left	—	—	***



Tilt and turn set

ECCENTRIC CUT

Hardware set combinations

Nº	Description	Application range by width	Application range by height	Part No.
10	Locking plate	—	—	***
10a	Locking plate safety	—	—	***
10b	Tilt locking plate safety	—	—	***
11	Lifting plate	—	751-2390	***
12	Wrong operation safety device with sash lifter	—	751-2390	A7001-00-N03
13	Corner bearing 3x3	—	—	A5002-00-N03
13a	Corner bearing 6x22	—	—	A5004-00-N03
14	Drill-in corner hinge 3x5	—	—	A5003-00-N03
14a	Drill-in corner hinge with gasket pressure adjustment 6x12	—	—	A5007-00-N03
14b	Drill-in corner hinge with gasket pressure adjustment 6x16/26	—	—	A5006-00-N03
14c	Rebate corner hinge 20/9 left	—	—	A5009-09-L03
	Rebate corner hinge 20/9 right	—	—	A5009-09-R03
	Rebate corner hinge 20/13 left	—	—	A5009-13-L03
	Rebate corner hinge 20/13 right	—	—	A5009-13-R03
15	Stay arm bearing 3x3	—	—	A5001-00-N03
15a	Stay arm bearing 6x24	—	—	A5005-00-N03
16	Top sash hinge	—	—	K5001-**-N03
17	Cover of top sash hinge	—	—	A7004-10-N****
18	Cover of stay arm bearing	—	—	A7005-10-N****
19	Cover of the drill-in corner hinge	—	—	A7006-10-N****
19a	Cover of rebate corner hinge, left / right	—	—	A7009-00-L/R****
20	Top cover of corner bearing	—	—	A7008-10-N****
21	Bottom cover of corner bearing	—	—	A7007-10-N****
27	Locking plate, integrated slit	—	—	***
28	Locking plate for adjustable integrated slit	—	—	***
29	Balcony catch	—	—	A7184-13-N03
29b	Balcony locking pin	—	—	A7207-00-N03
36a	Extension lock 480 mm, 1 ML	—	—	K4053-05-N03
	Extension lock 680 mm, 1 ML	—	—	K4053-07-N03
	Extension lock 880 mm, 2 ML	—	—	K4053-09-N03
38	Magnetic balcony catch, frame part	—	—	A7053-00-N03
38a	Magnetic balcony catch, sash part	—	—	A7055-**-N03
39	Extension lock 240 mm, 1 MR	—	—	K4050-02-N03
	Extension lock 480 mm, 1 MR	—	—	K4050-05-N03

* – displaced from the center

** – according to displacement axis of sash groove (9 mm, 10 mm, 13 mm, 14 mm)

*** – look at the section "Profile-depending elements"

**** – for decorative covers in other colors look at p. 27



Tilt and turn set “First Tilt”

Hardware set combinations

Tilt and turn set “First Tilt”, eccentric cut

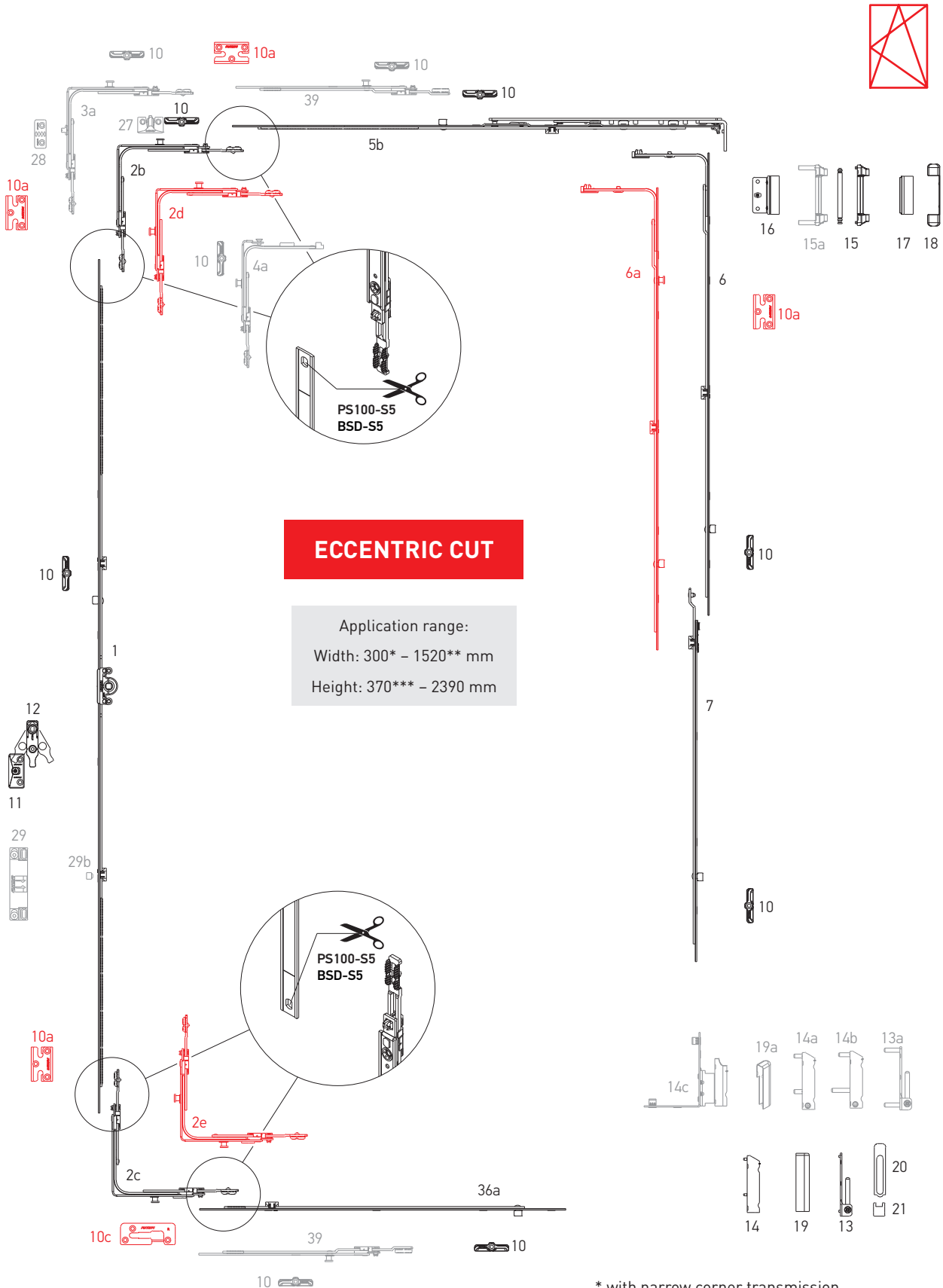

* with narrow corner transmission
 ** with the linear extension 240 mm
 *** with the constant gear K1004-04-N03

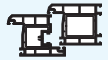

Tilt and turn set "First Tilt"

ECCENTRIC CUT

Hardware set combinations

Nº	Description	Application range by width	Application range by height	Part No.
1	Gear variable 0, L=320, 450-550	—	450-550	K1001-02-N03
	Gear variable 1, L=520, 551-750	—	551-750	K1001-04-N03
	Gear variable 2, L=1000, 751-1230, 1 ML	—	751-1230	K1001-09-N03
	Gear variable 3, L=1200, 950-1430, 1 ML	—	950-1430	K1001-11-N03
	Gear variable 4, L=1480, 1231-1710, 2 ML	—	1231-1710	K1001-14-N03
	Gear variable 5, L=1680, 1431-1910, 2 ML	—	1431-1910	K1001-16-N03
	Gear variable 6, L=2160, 1911-2390, 3 ML	—	1911-2390	K1001-21-N03
2b	Corner transmission, 1 MR, 115×115	400-1280	450-2390	K2025-00-N03
2c	Corner transmission, bottom, 1 MR, 115×115	400-1280	450-2390	K2028-00-N03
2d	Corner transmission, 2 MR, 115×115	400-1280	450-2390	K2032-00-N03
2e	Corner transmission, bottom, 2 MR, 115×115	400-1280	450-2390	K2029-00-N03
3a	Corner transmission, integrated slit, 1 MR, left/right, 115×115	400-1280	450-2390	K2034-00-L/R03
4a	Narrow corner transmission, 1 MR, 115×115	300-400	450-2390	K2026-00-N03
		400-600	370-550*	
5b	Stay arm 1, "First Tilt", L=485, 400-600	400-600	—	K3014-05-N03
	Stay arm 2, "First Tilt", L=685, 601-800	601-800	—	K3014-07-N03
	Stay arm 3, "First Tilt", L=915, 801-1040, 1 ML	801-1040	—	K3014-09-N03
	Stay arm 4, "First Tilt", L=1165, 1041-1280, 1 ML	1041-1280	—	K3014-11-N03
6	Middle lock L=400, 1 ML	600-1000	600-1000	K4001-04-N03
	Middle lock L=650, 1 ML	850-1250	850-1250	K4001-06-N03
	Middle lock L=720, 1 ML	920-1320	920-1320	K4001-07-N03
	Middle lock L=820, 1 ML	1251-1430	1251-1430	K4001-08-N03
	Middle lock L=1130, 2 ML	—	1251-1730	K4001-11-N03
6a	Middle lock L=400, 1 MR + 1 ML	600-1000	600-1000	K4008-04-N03
	Middle lock L=650, 1 MR + 1 ML	850-1250	850-1250	K4008-06-N03
	Middle lock L=820, 1 MR + 1 ML	1251-1430	1251-1430	K4008-08-N03
	Middle lock L=1130, 1 MR + 2 ML	—	1251-1730	K4008-11-N03
7	Middle lock extension, 1 ML, 480 mm	—	850-1230	K4005-05-N03
	Middle lock extension, 1 ML, 680 mm	—	1231-1430	K4005-07-N03
10	Locking plate	—	—	***
10a	Locking plate safety	—	—	***
10c	Tilt locking plate "First Tilt", left / right	—	—	***
11	Lifting plate	—	—	***
12	Wrong operation safety device with sash lifter	—	751-2390	A7001-00-N03
13	Corner bearing 3x3	—	—	A5002-00-N03
13a	Corner bearing 6x22	—	—	A5004-00-N03
14	Drill-in corner hinge 3x5	—	—	A5003-00-N03
14a	Drill-in corner hinge with gasket pressure adjustment 6x12	—	—	A5007-00-N03
14b	Drill-in corner hinge with gasket pressure adjustment 6x16/26	—	—	A5006-00-N03

Tilt and turn set “First Tilt”
ECCENTRIC CUT

Hardware set combinations

Nº	Description	Application range by width	Application range by height	Part No.
14C	Rebate corner hinge 20/9 left	—	—	A5009-09-L03
	Rebate corner hinge 20/9 right	—	—	A5009-09-R03
	Rebate corner hinge 20/13 left	—	—	A5009-13-L03
	Rebate corner hinge 20/13 right	—	—	A5009-13-R03
15	Stay arm bearing 3x3	—	—	A5001-00-N03
15a	Stay arm bearing 6x24	—	—	A5005-00-N03
16	Top sash hinge	—	—	K5001-**-N03
17	Cover of top sash hinge	—	—	A7004-10-N****
18	Cover of stay arm bearing	—	—	A7005-10-N****
19	Cover of the drill-in corner hinge	—	—	A7006-10-N****
19a	Cover of rebate corner hinge, left / right	—	—	A7009-00-L/R****
20	Top cover of corner bearing	—	—	A7008-10-N****
21	Bottom cover of corner bearing	—	—	A7007-10-N****
27	Locking plate, integrated slit	—	—	***
28	Locking plate for adjustable integrated slit	—	—	***
36a	Extension lock 480 mm, 1 ML	—	—	K4053-05-N03
	Extension lock 680 mm, 1 ML	—	—	K4053-07-N03
	Extension lock 880 mm, 2 ML	—	—	K4053-09-N03
39	Extension lock 240 mm, 1 MR	—	—	K4050-02-N03
	Extension lock 480 mm, 1 MR	—	—	K4050-05-N03

* – displaced from the center

** – according to displacement axis of sash groove (9 mm, 10 mm, 13 mm, 14 mm)

*** – look at the section “Profile-dependent elements”

**** – for decorative covers in other colors look at p. 27

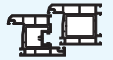

Turn set

Hardware set combinations

Turn set, eccentric cut

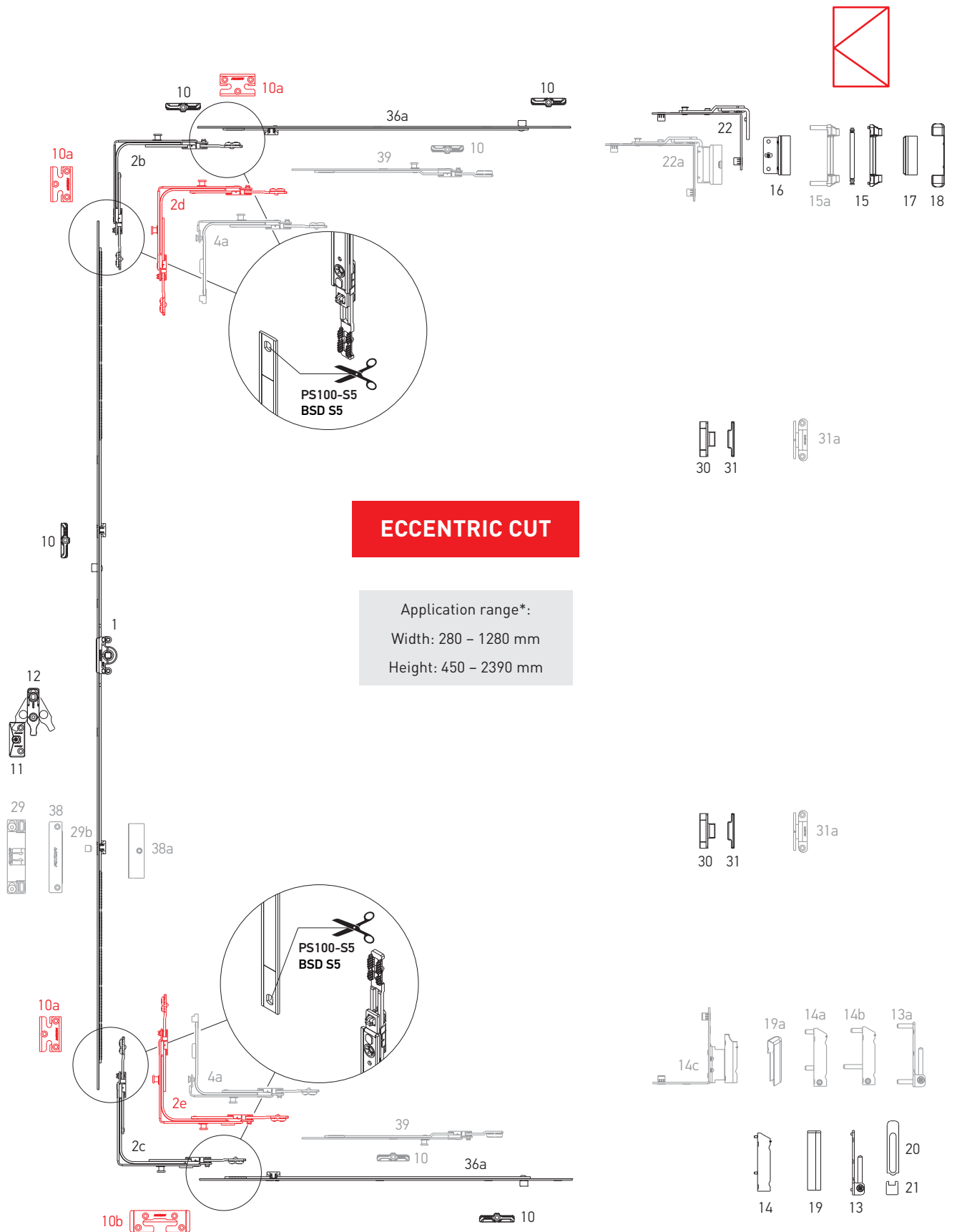

ECCENTRIC CUT

Application range*:
 Width: 280 - 1280 mm
 Height: 450 - 2390 mm

* Use the shoot-bolt 34, 34a



Turn set

ECCENTRIC CUT

Hardware set combinations

Nº	Description	Application range by width	Application range by height	Part No.
1	Gear variable 0, L=320, 450-550	—	450-550	K1001-02-N03
	Gear variable 1, L=520, 551-750	—	551-750	K1001-04-N03
	Gear variable 2, L=1000, 751-1230, 1 ML	—	751-1230	K1001-09-N03
	Gear variable 3, L=1200, 950-1430, 1 ML	—	950-1430	K1001-11-N03
	Gear variable 4, L=1480, 1231-1710, 2 ML	—	1231-1710	K1001-14-N03
	Gear variable 5, L=1680, 1431-1910, 2 ML	—	1431-1910	K1001-16-N03
	Gear variable 6, L=2160, 1911-2390, 3 ML	—	1911-2390	K1001-21-N03
2b	Corner transmission, 1 MR, 115×115	400-1280	450-2390	K2025-00-N03
2c	Corner transmission, bottom, 1 MR, 115×115	400-1280	450-2390	K2028-00-N03
2d	Corner transmission, 2 MR, 115×115	400-1280	450-2390	K2032-00-N03
2e	Corner transmission, bottom, 2 MR, 115×115	400-1280	450-2390	K2029-00-N03
4a	Narrow corner transmission, 1 MR, 115×15	300-400	450-2390	K2026-00-N03
		400-600	370-550*	
10	Locking plate	—	—	***
11	Lifting plate	—	751-2390	***
12	Wrong operation safety device with sash lifter	—	751-2390	A7001-00-N03
13	Corner bearing 3×3	—	—	A5002-00-N03
13a	Corner bearing 6×22	—	—	A5004-00-N03
14	Drill-in corner hinge 3×5	—	—	A5003-00-N03
14a	Drill-in corner hinge with gasket pressure adjustment 6×12	—	—	A5007-00-N03
14b	Drill-in corner hinge with gasket pressure adjustment 6×16/26	—	—	A5006-00-N03
14c	Rebate corner hinge 20/9 left/right	—	—	A5009-09-L/R03
	Rebate corner hinge 20/13 left/right	—	—	A5009-13-L/R03
15	Stay arm bearing 3×3	—	—	A5001-00-N03
15a	Stay arm bearing 6×24	—	—	A5005-00-N03
16	Top sash hinge	—	—	K5001-**-N03
17	Cover of top sash hinge	—	—	A7004-10-N*
18	Cover of stay arm bearing	—	—	A7005-10-N*
19	Cover of the drill-in corner hinge	—	—	A7006-10-N*
19a	Cover of rebate corner hinge, left / right	—	—	A7009-00-L/R*
20	Top cover of corner bearing	—	—	A7008-10-N*
21	Bottom cover of corner bearing	—	—	A7007-10-N*
22	Turn stay arm	—	—	K5002-00-N03
22a	Turn stay arm 12/20-13 left/right	—	—	K5014-13-L/R03
	Turn stay arm 12/20-9 left/right	—	—	K5014-09-L/R03
	Turn stay arm 12/20-13 left/right	—	—	S5001-13-L03/R
	Turn stay arm 12/20-9 left/right	—	—	S5001-09-L03/R
29	Balcony catch	—	—	A7184-13-N03
29b	Balcony locking pin	—	—	A7207-00-N03
30	Concealed middle hinge, sash part	—	—	A7056-00-N03
31	Concealed middle hinge, frame part	—	—	A7057-**-N03

Turn set
ECCENTRIC CUT

Hardware set combinations

Nº	Description	Application range by width	Application range by height	Part No.
31a	Middle hinge (white)	—	—	A7185-00-N01
	Middle hinge (brown)	—	—	A7185-00-N02
	Middle hinge (gray anthracite)	—	—	A7185-00-N09
36a	Extension lock 480 mm, 1 ML	—	—	K4053-05-N03
	Extension lock 680 mm, 1 ML	—	—	K4053-07-N03
	Extension lock 880 mm, 2 ML	—	—	K4053-09-N03
38	Magnetic balcony catch, frame part	—	—	A7053-00-N03
38a	Magnetic balcony catch, sash part	—	—	A7055-**-N03
39	Extension lock 240 mm, 1 MR	—	—	K4050-02-N03
	Extension lock 480 mm, 1 MR	—	—	K4050-05-N03

* – for decorative covers in other colors look at p. 27

** – according to displacement axis of sash groove (9 mm, 10 mm, 13 mm, 14 mm)

*** – look at the section "Profile-depending elements"



Tilt set

Hardware set combinations

Tilt set, eccentric cut.

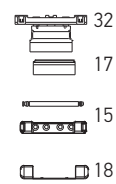
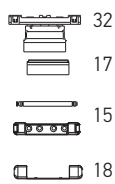
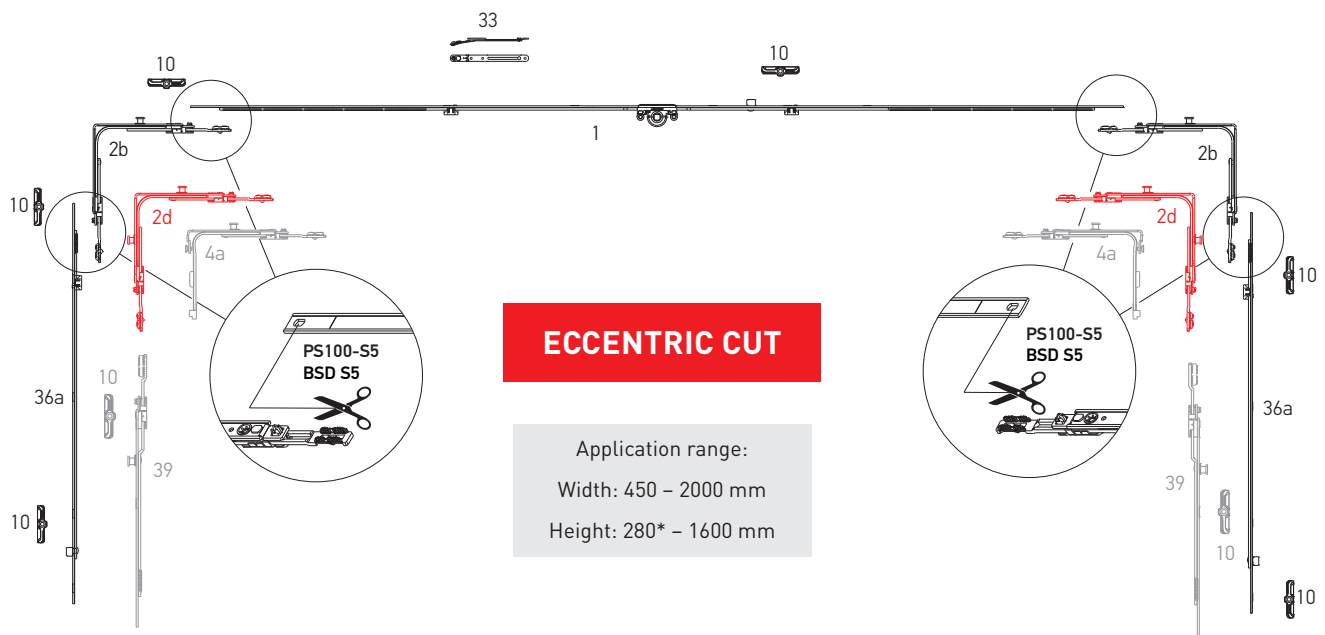
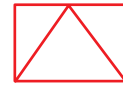

* without extension lock



Tilt set

ECCENTRIC CUT

Hardware set combinations

Nº	Description	Application range by width	Application range by height	Part No.
1	Gear variable 0, L=320, 450-550	—	450-550	K1001-02-N03
	Gear variable 1, L=520, 551-750	—	551-750	K1001-04-N03
	Gear variable 2, L=1000, 751-1230, 1 ML	—	751-1230	K1001-09-N03
	Gear variable 3, L=1200, 950-1430, 1 ML	—	950-1430	K1001-11-N03
	Gear variable 4, L=1480, 1231-1710, 2 ML	—	1231-1710	K1001-14-N03
	Gear variable 5, L=1680, 1431-1910, 2 ML	—	1431-1910	K1001-16-N03
	Gear variable 6, L=2160, 1911-2390, 3 ML	—	1911-2390	K1001-21-N03
2b	Corner transmission, 1 MR, 115×115	400-1280	450-2390	K2025-00-N03
2d	Corner transmission, 2 MR, 115×115	400-1280	450-2390	K2032-00-N03
4a	Narrow corner transmission, 1 MR, 115×15	300-400	450-2390	K2026-00-N03
		400-600	370-550*	
10	Locking plate	—	—	***
15	Stay arm bearing 3×3	—	—	A5001-00-N03
17	Cover of top sash hinge	—	—	A7004-10-N*
18	Cover of stay arm bearing	—	—	A7005-10-N*
30	Concealed middle hinge, sash part	—	—	A7056-00-N03
31	Concealed middle hinge, frame part	—	—	A7057-**-N03
31a	Middle hinge (white)	—	—	A7185-00-N01
	Middle hinge (brown)	—	—	A7185-00-N02
	Middle hinge (gray anthracite)	—	—	A7185-00-N09
32	Bottom hinges for tilt sash	—	—	A7014-**-N03
33	Tilt stay arm	—	—	A7107-00-N03
	Tilt stay arm	—	—	A7017-00-N03
36a	Extension lock 480 mm, 1 ML	—	—	K4053-05-N03
	Extension lock 680 mm, 1 ML	—	—	K4053-07-N03
	Extension lock 880 mm, 2 ML	—	—	K4053-09-N03
39	Extension lock 240 mm, 1 MR	—	—	K4050-02-N03
	Extension lock 480 mm, 1 MR	—	—	K4050-05-N03

* – for decorative covers in other colors look at p. 27

** – according to displacement axis of sash groove (9 mm, 10 mm, 13 mm, 14 mm)

*** – look at the section “Profile-dependent elements”



Double sash set

Hardware set combinations

Secondary sash of double-sash window

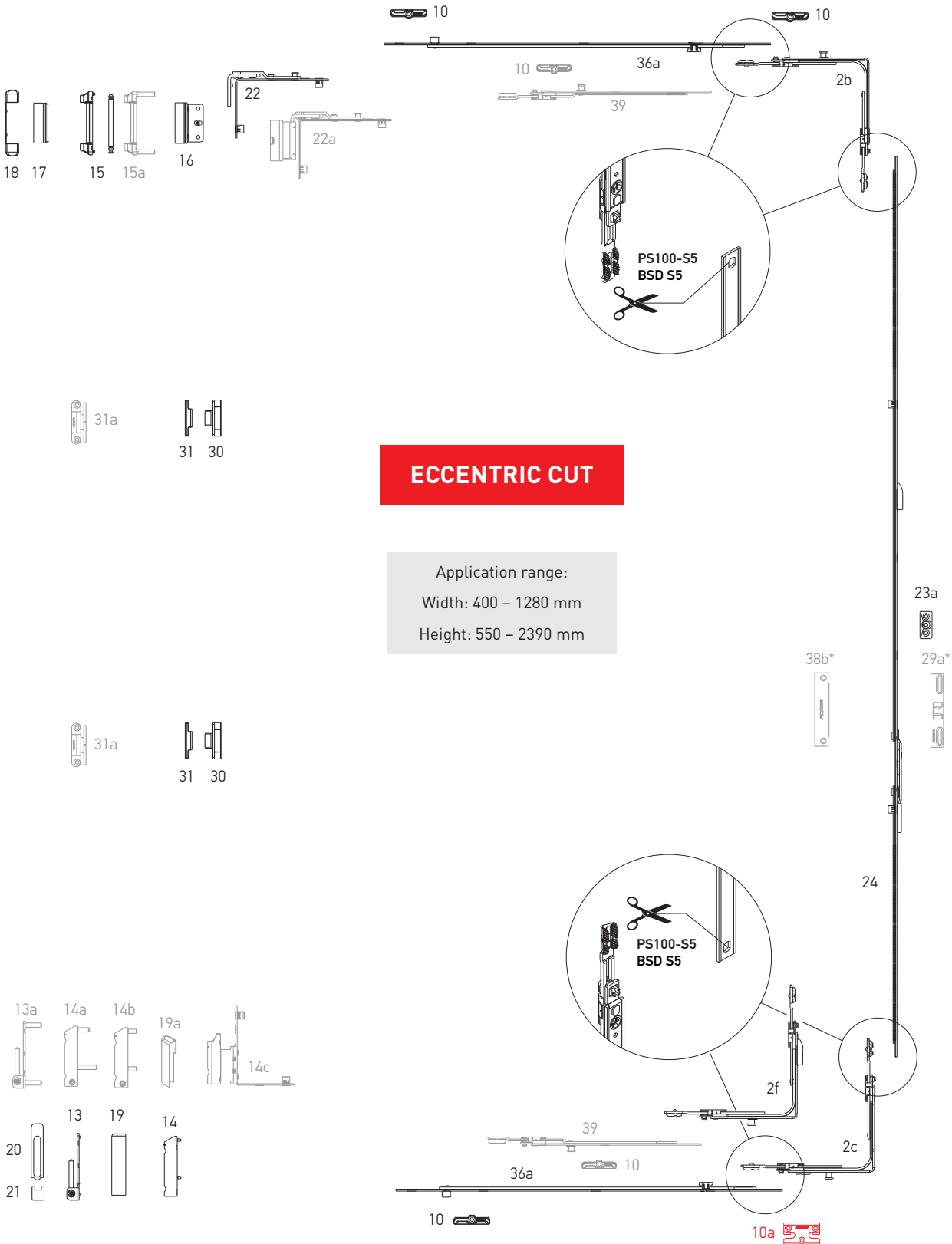
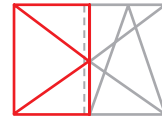

ECCENTRIC CUT

Application range:
Width: 400 - 1280 mm
Height: 550 - 2390 mm



Double sash set

Hardware set combinations

Main sash

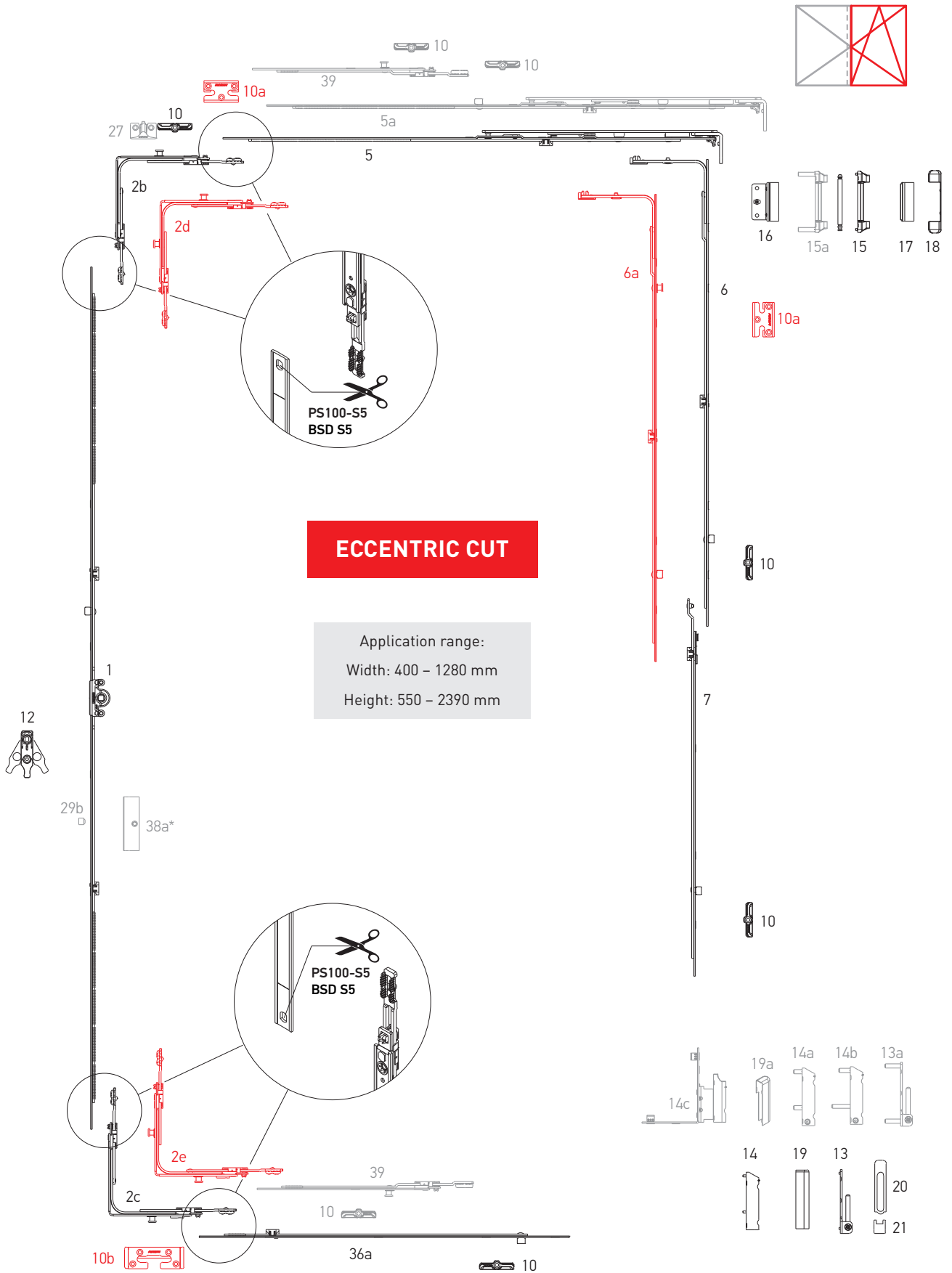

* – only with gear K1002-21-N03



Double sash set

ECCENTRIC CUT

Hardware set combinations

Nº	Description	Application range by width	Application range by height	Part No.
1	Gear variable 1, L=520, 551-750	—	551-750	K1001-04-N03
	Gear variable 2, L=1000, 751-1230, 1 ML	—	751-1230	K1001-09-N03
	Gear variable 3, L=1200, 950-1430, 1 ML	—	950-1430	K1001-11-N03
	Gear variable 5, L=1680, 1431-1910, 2 ML	—	1431-1910	K1001-16-N03
	Gear variable 6, L=2160, 1911-2390, 3 ML	—	1911-2390	K1001-21-N03
2b	Corner transmission, 1 MR, 115×115	400-1280	450-2390	K2025-00-N03
2c	Corner transmission, bottom, 1 MR, 115×115	400-1280	450-2390	K2028-00-N03
2d	Corner transmission, 2 MR, 115×115	400-1280	450-2390	K2032-00-N03
2e	Corner transmission, bottom, 2 MR, 115×115	400-1280	450-2390	K2029-00-N03
2f	Corner transmission, double sash, bottom, 1 MR, 115×115	400-1280	550-2390	K2030-00-N03
5	Stay arm 1, L=485, 400-600	400-600	—	K3001-05-N03
	Stay arm 2, L=685, 601-800	601-800	—	K3001-07-N03
	Stay arm 3, L=925, 801-1040, 1 ML	801-1040	—	K3001-09-N03
	Stay arm 4, L=1165, 1041-1280, 1 ML	1041-1280	—	K3001-11-N03
5a	Stay arm 2, L=685, 601-800, 1 ML	601-800	—	K3001-57-N03
6	Middle lock L=400, 1 ML	600-1000	600-1000	K4001-04-N03
	Middle lock L=650, 1 ML	850-1250	850-1250	K4001-06-N03
	Middle lock L=720, 1 ML	920-1320	920-1320	K4001-07-N03
	Middle lock L=820, 1 ML	1251-1430	1251-1430	K4001-08-N03
	Middle lock L=1130, 2 ML	—	1251-1730	K4001-11-N03
6a	Middle lock L=400, 1 MR + 1 ML	600-1000	600-1000	K4008-04-N03
	Middle lock L=650, 1 MR + 1 ML	850-1250	850-1250	K4008-06-N03
	Middle lock L=820, 1 MR + 1 ML	1251-1430	1251-1430	K4008-08-N03
	Middle lock L=1130, 1 MR + 2 ML	—	1251-1730	K4008-11-N03
7	Middle lock extension, 1 ML, 480 mm	—	1710-2210	K4005-05-N03
	Middle lock extension, 1 ML, 680 mm	—	2231-2390	K4005-07-N03
10	Locking plate	—	—	***
10a	Locking plate safety	—	—	***
10b	Tilt locking plate safety	—	—	***
12	Wrong operation safety device with sash lifter	—	751-2390	A7001-00-N03
13	Corner bearing 3×3	—	—	A5002-00-N03
13a	Corner bearing 6×22	—	—	A5004-00-N03
14	Drill-in corner hinge 3×5	—	—	A5003-00-N03
14a	Drill-in corner hinge with gasket pressure adjustment 6×12	—	—	A5006-00-N03
14b	Drill-in corner hinge with gasket pressure adjustment 6×16/26	—	—	A5007-00-N03
14C	Rebate corner hinge 20/9 left	—	—	A5009-09-L03
	Rebate corner hinge 20/9 right	—	—	A5009-09-R03
	Rebate corner hinge 20/13 left	—	—	A5009-13-L03
	Rebate corner hinge 20/13 right	—	—	A5009-13-R03
15	Stay arm bearing 3×3	—	—	A5001-00-N03
15a	Stay arm bearing 6×24	—	—	A5005-00-N03
16	Top sash hinge	—	—	K5001-**-N03



Double sash set

ECENTRIC CUT

Hardware set combinations

Nº	Description	Application range by width	Application range by height	Part No.
17	Cover of top sash hinge	—	—	A7004-10-N*
18	Cover of stay arm bearing	—	—	A7005-10-N*
19	Cover of the drill-in corner hinge	—	—	A7006-10-N*
19a	Cover of rebate corner hinge, left / right	—	—	A7009-00-L/R*
20	Top cover of corner bearing	—	—	A7008-10-N*
21	Bottom cover of corner bearing	—	—	A7007-10-N*
22	Turn stay arm	—	—	K5002-00-N03
22a	Turn stay arm 12/20-13 left/right	—	—	K5014-13-L/R03
	Turn stay arm 12/20-9 left/right	—	—	K5014-09-L/R03
	Turn stay arm 12/20-13 left/right	—	—	S5001-13-L03/R
	Turn stay arm 12/20-9 left/right	—	—	S5001-09-L03/R
23a	Lifting plate plate for double-sash window	—	—	A6001-00-N03
24	Double-sash gear 1 L=520, 551-750	—	551-750	K1002-04-N03
	Double-sash gear 2 L=720, 751-950	—	751-950	K1002-06-N03
	Double-sash gear 3 L=1200, 951-1430	—	951-1430	K1002-11-N03
	Double-sash gear 4 L=1680, 1431-1910	—	1431-1910	K1002-16-N03
	Double-sash gear 5 L=2160, 1911-2390	—	1911-2390	K1002-21-N03
27	Locking plate, integrated slit	—	—	***
29a	Balcony catch for double-sash gear	—	1911-2390	A7047-00-N03
29b	Balcony locking pin	—	—	A7207-00-N03
30	Concealed middle hinge, sash part	—	—	A7056-00-N03
31	Concealed middle hinge, frame part	—	—	A7057-**-N03
31a	Middle hinge (white)	—	—	A7185-00-N01
	Middle hinge (brown)	—	—	A7185-00-N02
	Middle hinge (gray anthracite)	—	—	A7185-00-N09
36a	Extension lock 480 mm, 1 ML	—	—	K4053-05-N03
	Extension lock 680 mm, 1 ML	—	—	K4053-07-N03
	Extension lock 880 mm, 2 ML	—	—	K4053-09-N03
38a	Magnetic balcony catch, sash part	—	—	A7055-**-N03
38b	Magnetic balcony catch for double-sash gear, frame part	—	—	A7054-00-N03
39	Extension lock 240 mm, 1 MR	—	—	K4050-02-N03
	Extension lock 480 mm, 1 MR	—	—	K4050-05-N03

* – for decorative covers in other colors look at p. 27

** – according to displacement axis of sash groove (9 mm, 10 mm, 13 mm, 14 mm)

*** – look at the section "Profile-depending elements"

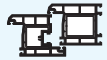

Double sash set "First Tilt"

Hardware set combinations

Secondary sash of double-sash window "First Tilt"

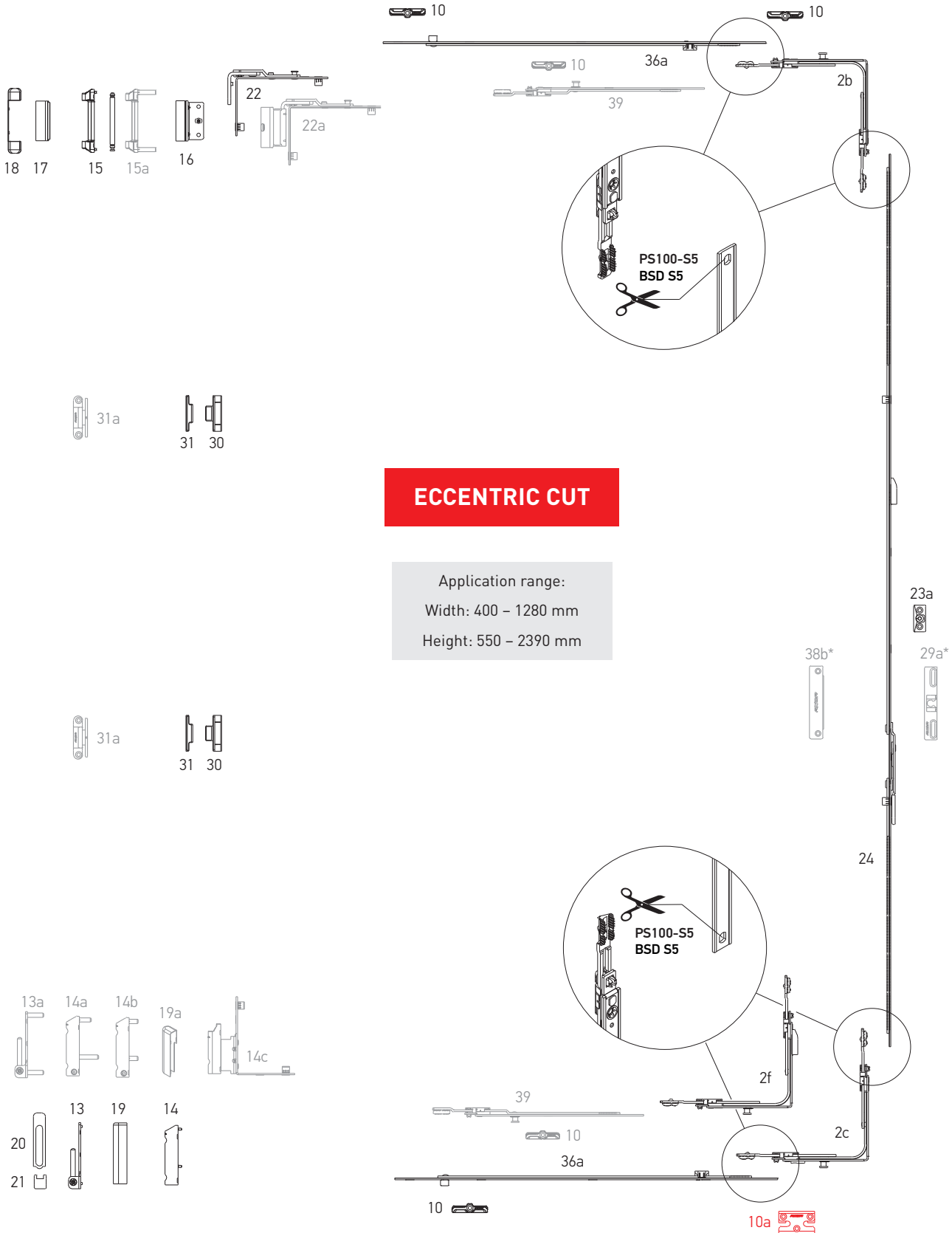
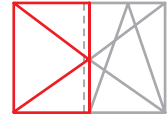

ECCENTRIC CUT

Application range:
Width: 400 – 1280 mm
Height: 550 – 2390 mm



Double sash set "First Tilt"

Hardware set combinations

Main sash "First Tilt"

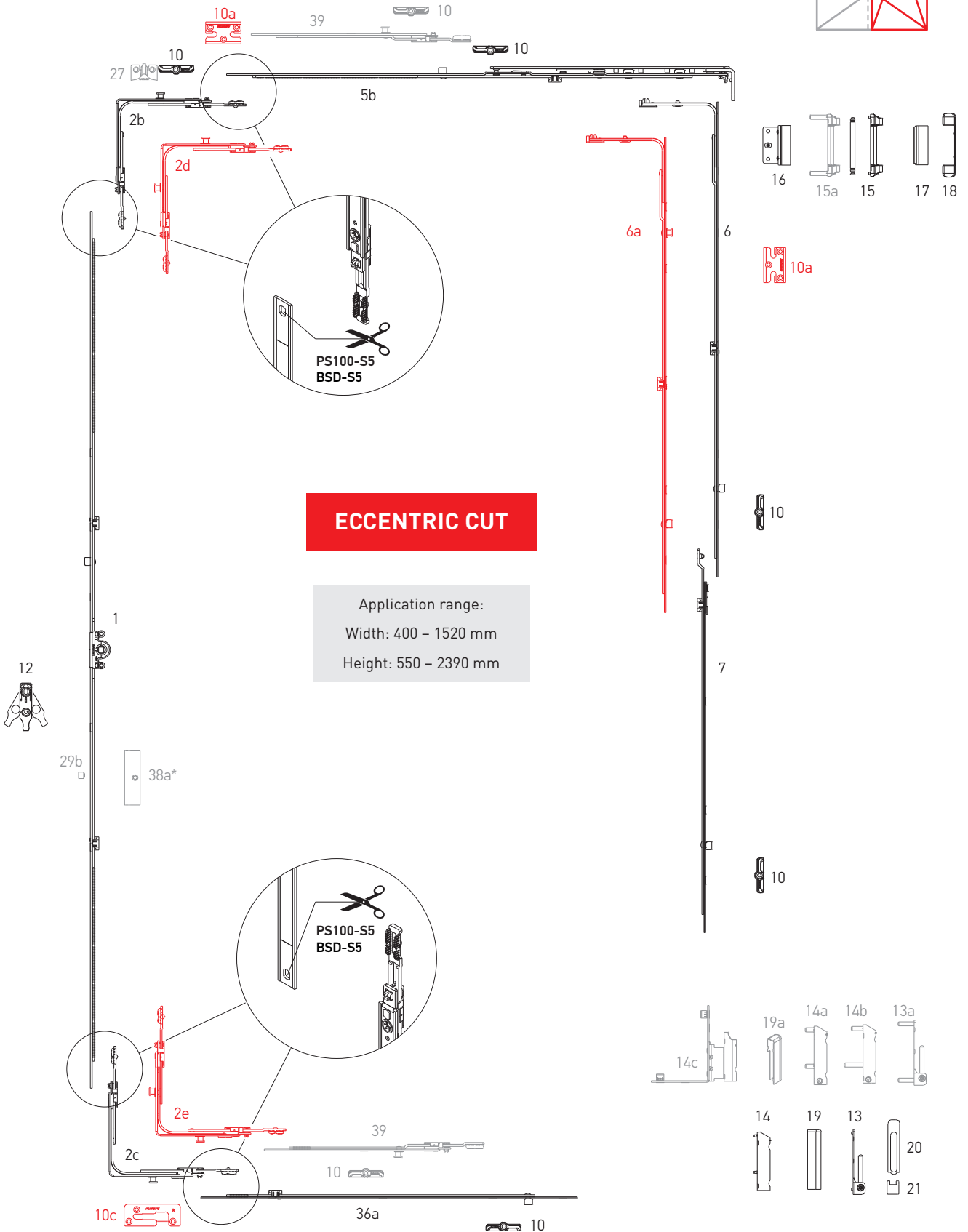
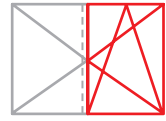

ECCENTRIC CUT

Application range:
Width: 400 - 1520 mm
Height: 550 - 2390 mm



Double sash set "First Tilt"

ECCENTRIC CUT

Hardware set combinations

Nº	Description	Application range by width	Application range by height	Part No.
1	Gear variable 1, L=520, 551-750	—	551-750	K1001-04-N03
	Gear variable 2, L=1000, 751-1230, 1 ML	—	751-1230	K1001-09-N03
	Gear variable 3, L=1200, 950-1430, 1 ML	—	950-1430	K1001-11-N03
	Gear variable 5, L=1680, 1431-1910, 2 ML	—	1431-1910	K1001-16-N03
	Gear variable 6, L=2160, 1911-2390, 3 ML	—	1911-2390	K1001-21-N03
2b	Corner transmission, 1 MR, 115×115	400-1280	450-2390	K2025-00-N03
2c	Corner transmission, bottom, 1 MR, 115×115	400-1280	450-2390	K2028-00-N03
2d	Corner transmission, 2 MR, 115×115	400-1280	450-2390	K2032-00-N03
2e	Corner transmission, bottom, 2 MR, 115×115	400-1280	450-2390	K2029-00-N03
2f	Corner transmission, double sash, bottom, 1 MR, 115×115	400-1280	550-2390	K2030-00-N03
5b	Stay arm 1, "First Tilt", L=485, 400-600	400-600	—	K3014-05-N03
	Stay arm 2, "First Tilt", L=685, 601-800	601-800	—	K3014-07-N03
	Stay arm 3, "First Tilt", L=915, 801-1040, 1 ML	801-1040	—	K3014-09-N03
	Stay arm 4, "First Tilt", L=1165, 1041-1280, 1 ML	1041-1280	—	K3014-11-N03
6	Middle lock L=400, 1 ML	—	600-1000	K4001-04-N03
	Middle lock L=650, 1 ML	—	850-1250	K4001-06-N03
	Middle lock L=720, 1 ML	—	920-1320	K4001-07-N03
	Middle lock L=820, 1 ML	—	1251-1430	K4001-08-N03
	Middle lock L=1130, 2 ML	—	1251-1730	K4001-11-N03
6a	Middle lock L=400, 1 MR + 1 ML	—	600-1000	K4008-04-N03
	Middle lock L=650, 1 MR + 1 ML	—	850-1250	K4008-06-N03
	Middle lock L=820, 1 MR + 1 ML	—	1251-1430	K4008-08-N03
	Middle lock L=1130, 1 MR + 2 ML	—	1251-1730	K4008-11-N03
7	Middle lock extension, 1 ML, 480 mm	—	850-1230	K4005-05-N03
	Middle lock extension, 1 ML, 680 mm	—	1231-1430	K4005-07-N03
10	Locking plate	—	—	***
10a	Locking plate safety	—	—	***
10C	Tilt locking plate "First Tilt", left / right	—	—	***
12	Wrong operation safety device with sash lifter	—	751-2390	A7001-00-N03
13	Corner bearing 3×3	—	—	A5002-00-N03
13a	Corner bearing 6×22	—	—	A5004-00-N03
14	Drill-in corner hinge 3×5	—	—	A5003-00-N03
14a	Drill-in corner hinge with gasket pressure adjustment 6×12	—	—	A5006-00-N03
14b	Drill-in corner hinge with gasket pressure adjustment 6×12/26	—	—	A5007-00-N03
14C	Rebate corner hinge 20/9 left	—	—	A5009-09-L03
	Rebate corner hinge 20/9 right	—	—	A5009-09-R03
	Rebate corner hinge 20/13 left	—	—	A5009-13-L03
	Rebate corner hinge 20/13 right	—	—	A5009-13-R03
15	Stay arm bearing 3×3	—	—	A5001-00-N03
15a	Stay arm bearing 6×24	—	—	A5005-00-N03



Double sash set “First Tilt”

ECENTRIC CUT

Hardware set combinations

Nº	Description	Application range by width	Application range by height	Part No.
16	Top sash hinge	—	—	***
17	Cover of top sash hinge	—	—	A7004-10-N*
18	Cover of stay arm bearing	—	—	A7005-10-N*
19	Cover of the drill-in corner hinge	—	—	A7006-10-N*
19a	Cover of rebate corner hinge, left / right	—	—	A7009-00-L/R*
20	Top cover of corner bearing	—	—	A7008-10-N*
21	Bottom cover of corner bearing	—	—	A7007-10-N*
22	Turn stay arm	—	—	K5002-00-N03
22a	Turn stay arm 12/20-13 left/right	—	—	K5014-13-L/R03
	Turn stay arm 12/20-9 left/right	—	—	K5014-09-L/R03
	Turn stay arm 12/20-13 left/right	—	—	S5001-13-L03/R
	Turn stay arm 12/20-9 left/right	—	—	S5001-09-L03/R
23a	Lifting plate plate for double-sash window	—	—	***
24	Double-sash gear 1 L=520, 551-750	—	551-750	K1002-04-N03
	Double-sash gear 2 L=720, 751-950	—	751-950	K1002-06-N03
	Double-sash gear 3 L=1200, 951-1430	—	951-1430	K1002-11-N03
	Double-sash gear 4 L=1680, 1431-1910	—	1431-1910	K1002-16-N03
	Double-sash gear 5 L=2160, 1911-2390	—	1911-2390	K1002-21-N03
27	Locking plate, integrated slit	—	—	***
29a	Balcony catch for double-sash gear	—	1911-2390	A7047-00-N03
29b	Balcony locking pin	—	—	A7207-00-N03
30	Concealed middle hinge, sash part	—	—	A7056-00-N03
31	Concealed middle hinge, frame part	—	—	A7057-**-N03
31a	Middle hinge (white)	—	—	A7185-00-N01
	Middle hinge (brown)	—	—	A7185-00-N02
	Middle hinge (gray anthracite)	—	—	A7185-00-N09
36a	Extension lock 480 mm, 1 ML	—	—	K4053-05-N03
	Extension lock 680 mm, 1 ML	—	—	K4053-07-N03
	Extension lock 880 mm, 2 ML	—	—	K4053-09-N03
38a	Magnetic balcony catch, sash part	—	—	A7055-**-N03
38b	Magnetic balcony catch for double-sash gear	—	—	A7054-13-N03
39	Extension lock 240 mm, 1 MR	—	—	K4050-02-N03
	Extension lock 480 mm, 1 MR	—	—	K4050-05-N03

* – for decorative covers in other colors look at p. 27

** – according to displacement axis of sash groove (9 mm, 10 mm, 13 mm, 14 mm)

*** – look at the section “Profile-depending elements”

AXORTM

KOMFORT LINE K-3

Tools

Installation

Adjustments

AXOR

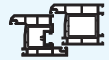

Information for an adjustment of jigs constant gear

Installation tools

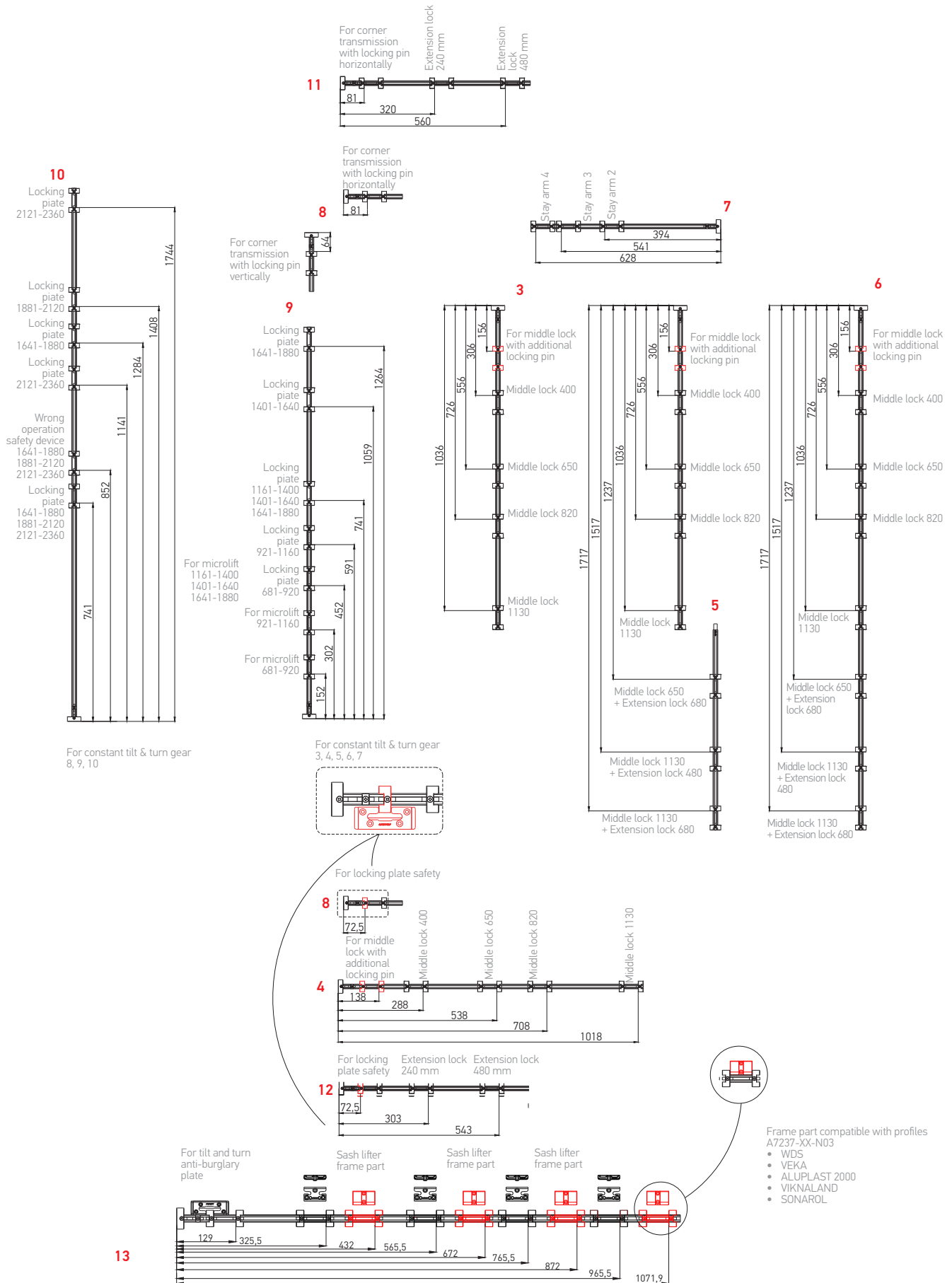

All dimensions are approximate and are subject to verification during production start-up.

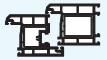

Locking plate jigs

Installation tools

Nº	Description	Designation	Part No.
1	Telescopic jig GV 2	For tilt-and-turn gear 5, 6. The handle is positioned in center.	A7024-02-N00
2	Telescopic jig GV 1	For tilt-and-turn gear 2,3,4. The handle is positioned in center.	A7024-01-N00
3	Linear jig MLV	For all vertical middle locks.	A7026-00-N00
4	Linear jig MLH	For all horizontal middle locks.	A7028-00-N00
5	Linear jig MLEV + MLV	For all vertical middle lock extensions + for all vertical middle locks (set).	A7027-00-N00
6	Linear jig MLMLEV	For all vertical middle locks, all middle lock extensions.	A7231-00-N00
7	Linear jig SA	For stay-arms of all sizes.	A7032-00-N00
8	Linear jig CTCP 1	For corner transmission with vertical locking pin.	A7025-00-N00
9	Linear jig CG	For constant tilt & turn gear 3, 4, 5, 6, 7.	A7065-01-N00
10	Linear jig CG	For constant tilt & turn gear 8, 9, 10.	A7065-02-N00
11	Linear jig EL-T	For extension locks with catcher, top.	A7229-00-N00
12	Linear jig EL-B	For extension locks with catcher, bottom.	A7230-00-N00
13	Striker plate template for sash lifter	For extension locks with lifters	A7257-00-N03



Installation of frame hardware components

Installation tools

Installation of frame hardware components

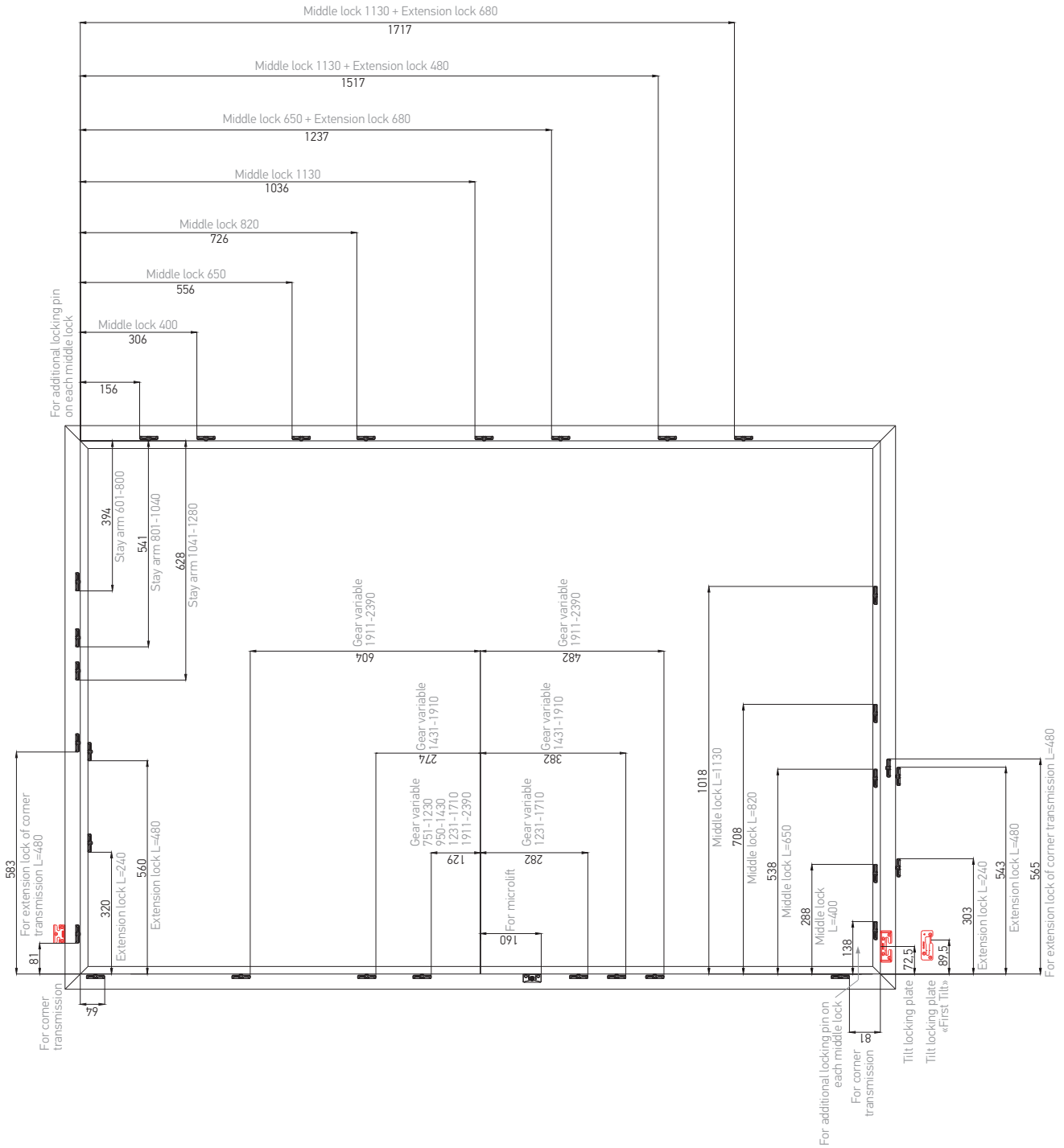



Installation of frame hardware components

Installation tools

Installation of frame hardware components using a constant gears

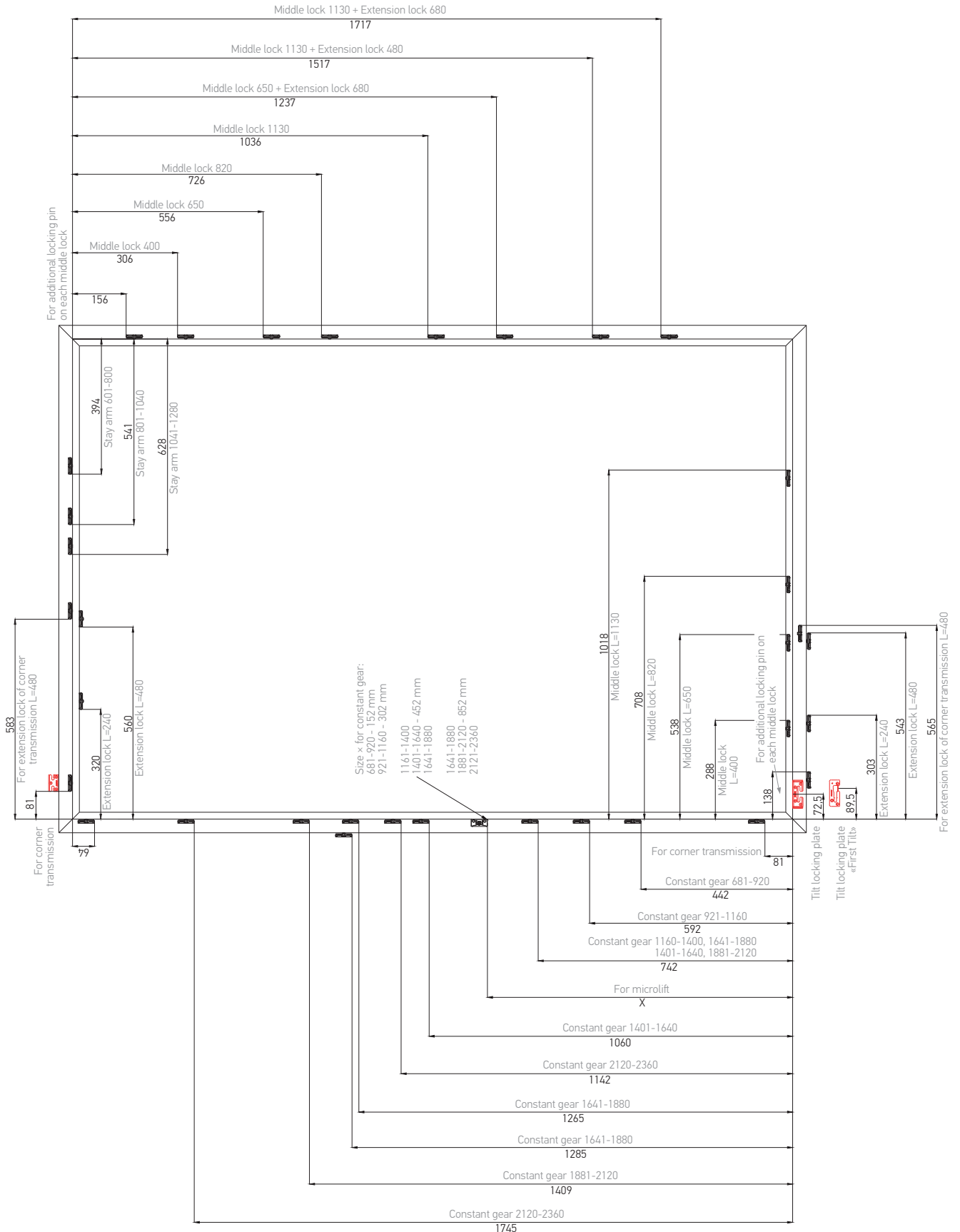

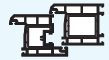

Location of locking plates

Installation tools

Location of locking plates with using of single turn gears, backset of ones is 15 mm.

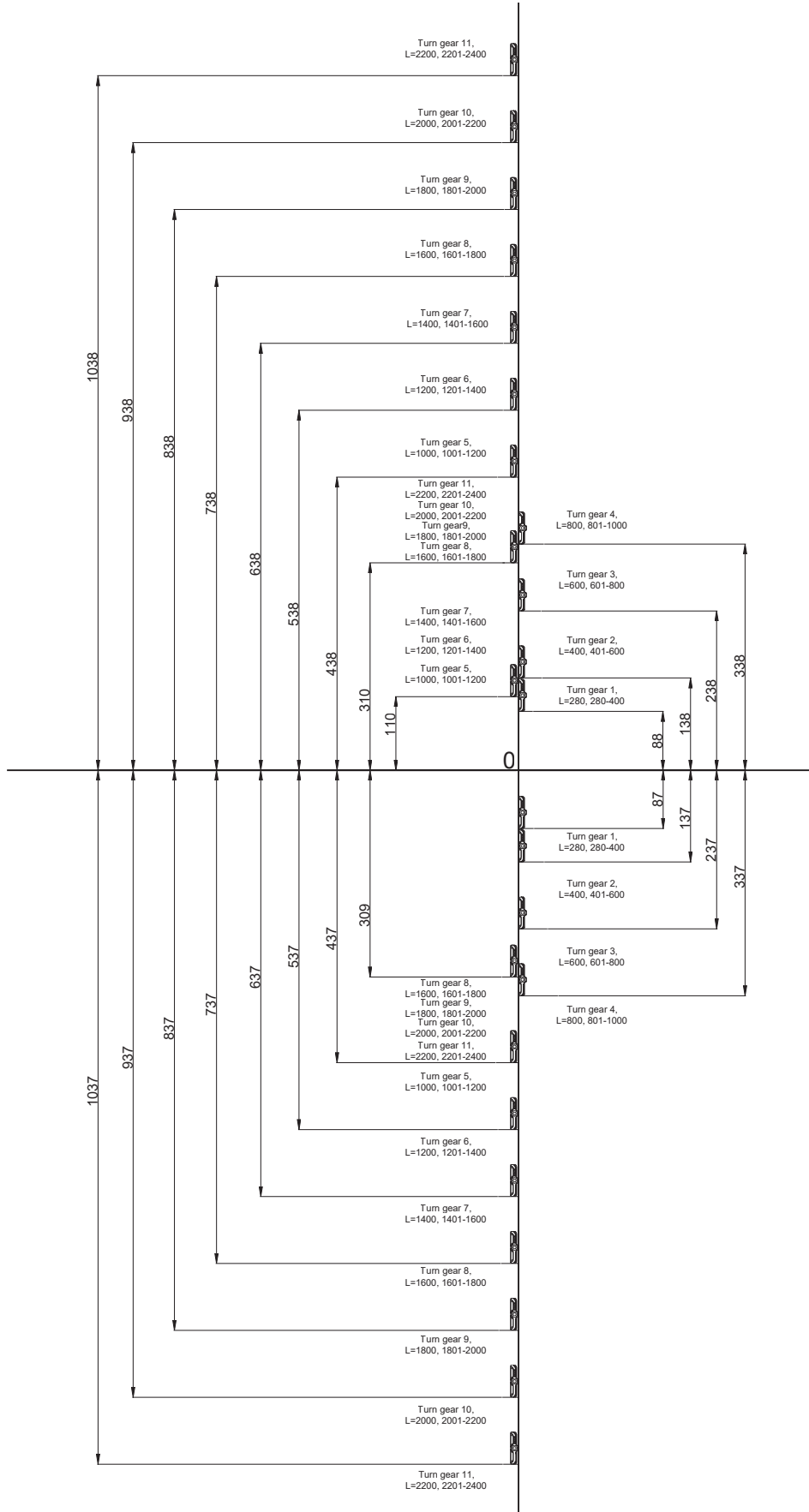



Jigs for hinges

Installation tools

Drilling jig for frame hinges

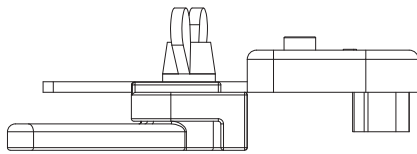
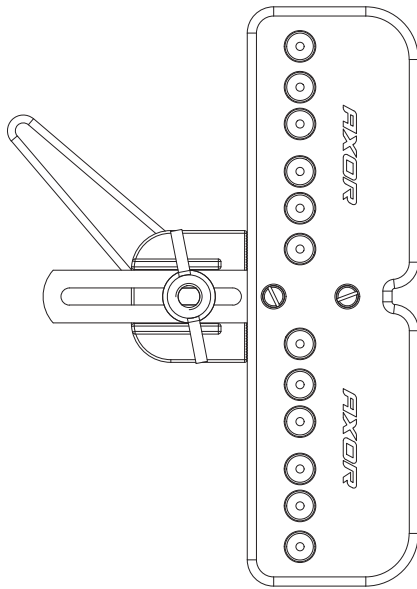

Drilling jig for sash hinges

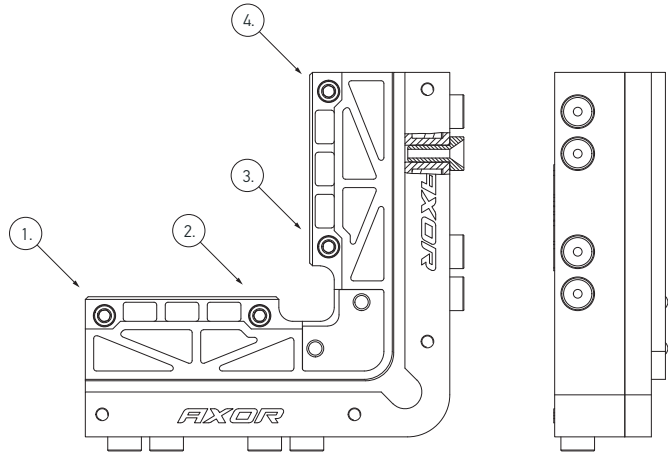

1-4. Adjustment screws use for jig fixation in sash groove.

Adjustment plate



Description	Profile	Designation	Tool		Part No.
Drilling jig for frame hinges	12/20	For drilling holes for top and bottom frame hinges	drill Ø3	50	A7002-00-N09
Drilling jig for frame hinges	12/21	For drilling holes for top and bottom frame hinges	drill Ø3	50	A7002-20-N09
Drilling jig for sash hinges	12/20-13; 12/20-9	For drilling holes for bottom sash hinge	drill Ø3	80	A7003-00-N09
Drilling jig for sash hinges	12/21-13; 12/21-9	For drilling holes for bottom sash hinge	drill Ø3	80	A7003-20-N09
Adjustment plate 0,5 mm	—	For sash jig adjustment	—	1	10073-05-N08
Adjustment plate 0,7 mm	—	For sash jig adjustment	—	1	10073-07-N08
Adjustment plate 1 mm	—	For sash jig adjustment	—	1	10073-10-N08



Jigs for hinges 130 kg

Installation tools

Drilling jig for frame hinges 130 kg

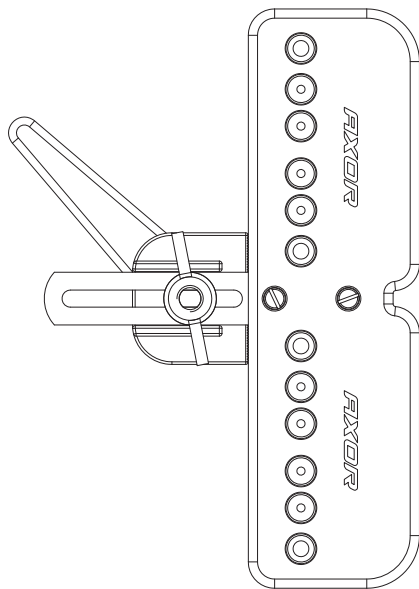

Drilling jig for sash hinges 130 kg

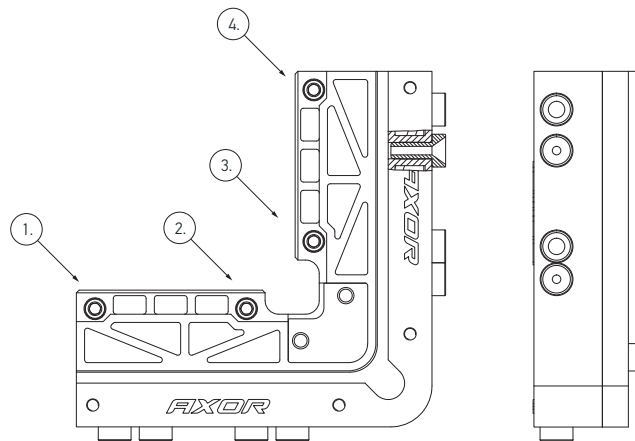

1-4. Adjustment screws use for jig fixation in sash groove.

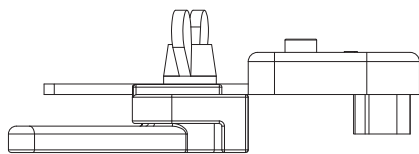

Adjustment plate



Description	Profile	Designation	Tool		Part No.
Drilling jig for frame hinges 130 kg	12/20	For drilling holes for top and bottom frame hinges	drill Ø3/6	50	A7002-10-N09
Drilling jig for frame hinges 130 kg	12/21	For drilling holes for top and bottom frame hinges	drill Ø3/6	50	A7002-30-N09
Drilling jig for sash hinges 130 kg	12/20-13; 12/20-9	For drilling holes for bottom sash hinge	drill Ø3/6	80	A7003-10-N09
Drilling jig for sash hinges 130 kg	12/21-13; 12/21-9	For drilling holes for bottom sash hinge	drill Ø3/6	80	A7003-30-N09
Adjustment plate 0,5 mm	—	For sash jig adjustment	—	1	10073-05-N08
Adjustment plate 0,7 mm	—	For sash jig adjustment	—	1	10073-07-N08
Adjustment plate 1 mm	—	For sash jig adjustment	—	1	10073-10-N08



Adjustment keys

Installation tools

Allen key U type

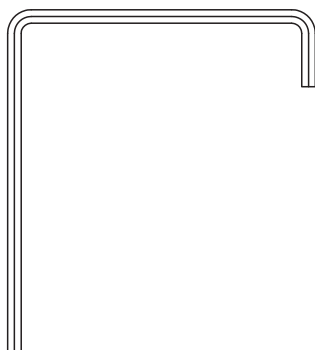

Allen key (L type plastic coated)

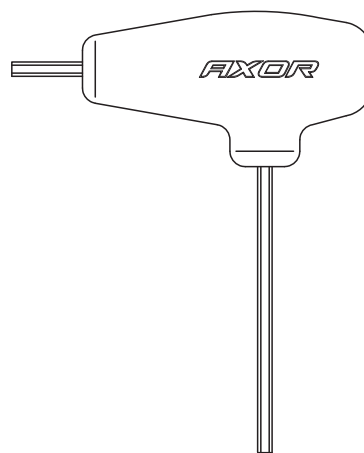

Mounting square handle

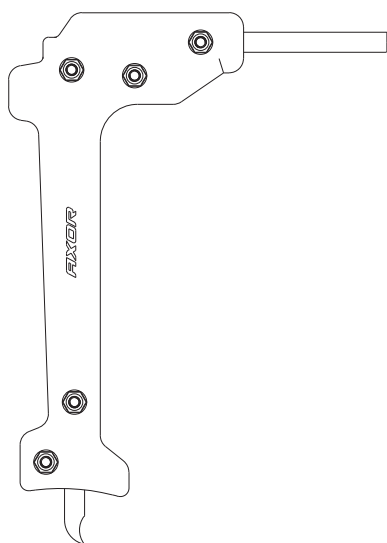

Description	Product group		Part No.
Allen key U type	K3-S+	100	A7020-00-N03
Allen key (L type plastic coated)	K3-S+	12	A7021-00-N03
AXOR mounting square handle	K3-S+	1	A7179-00-N03



Installation recommendations

Adjustment

Installation tools

Sash installation

The pin should be installed only when the sash has been closed and the handle is in "Tilt" position.
Caution!
 After the pin has been installed to rotate the handle to "Closed" position.

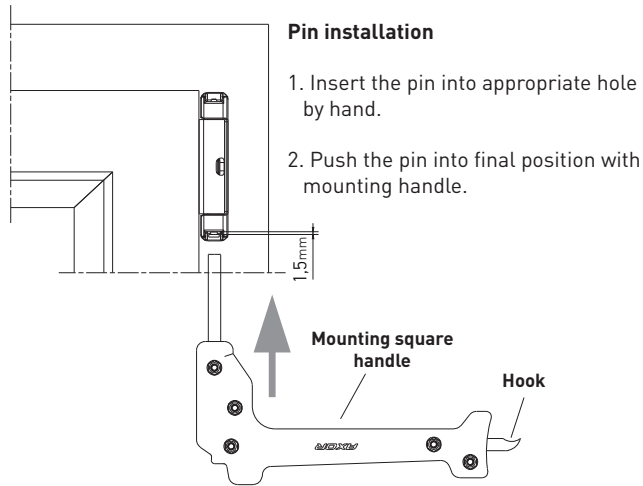

Sash removing

The pin should be removed only when the window has been closed and the handle is in "Tilted" position. Then, after the pin has been removed to turn the handle to "Open" position and to remove the sash.

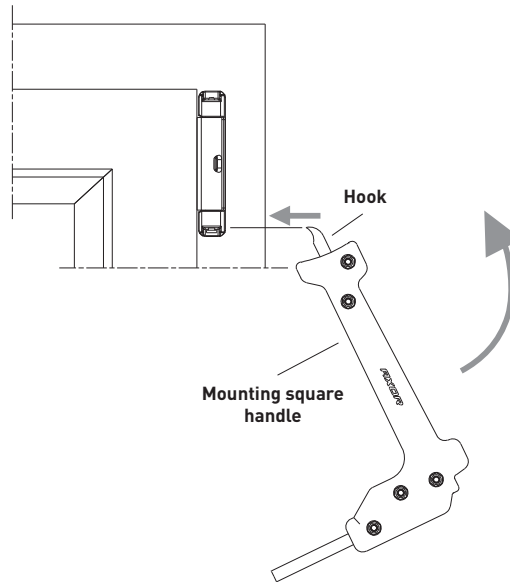

Stay arm

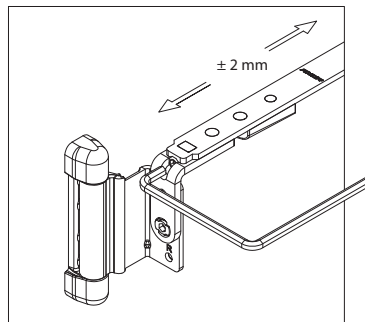
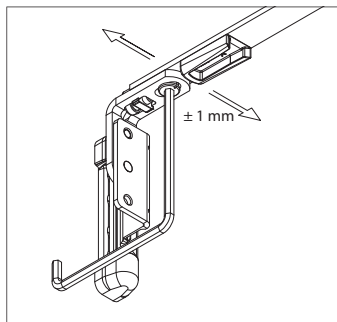

Drill-in corner hinge

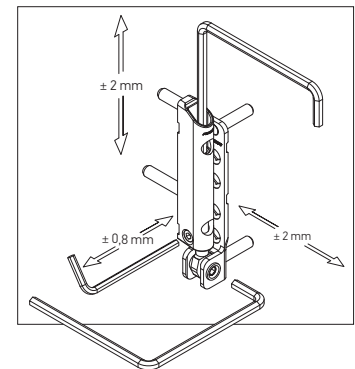

Turn stay arm

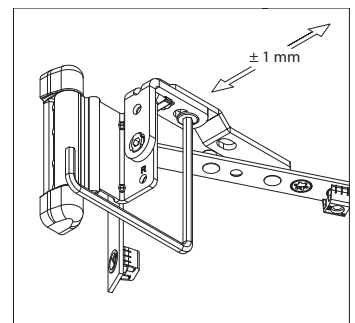
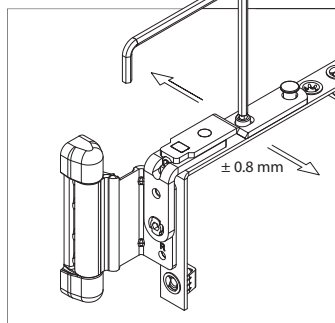
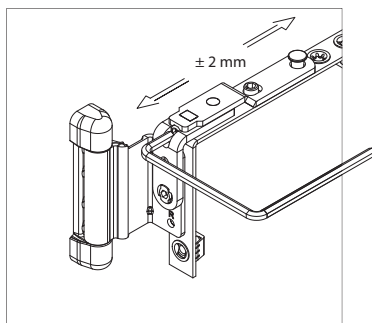



Installation recommendations
Adjustment

Installation tools

Locking pin	Rotation direction	Adjustment limits	Locking pin	Rotation direction	Adjustment limits	Locking pin	Rotation direction	Adjustment limits
ML		HEX 4	MR		HEX 4	FX		TORX 15
		+/-1			+/-1			+/-1

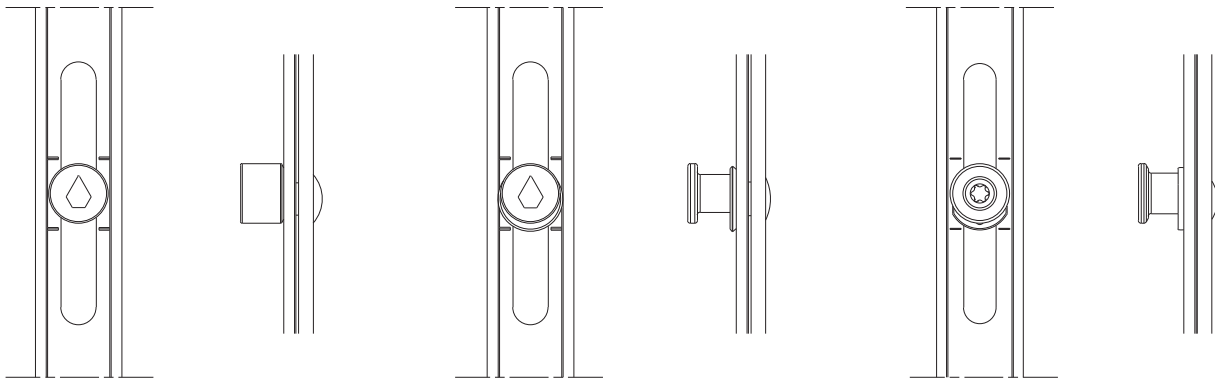

Installation recommendations

For hinge installation it is recommended to drill 3-mm hole in plastic and reinforcement profile, then to screw the hinge with screws without drill-bit.

For normal hinge load of 100/130 kg, it is **NECESSARY** to fix the hinge that ALL screws DIN 7982 3.9 × 38 mm (4 pcs) go into a reinforcing profile of a frame. If only 3 self-tapping screws go into the reinforcing profile of the frame, the weight of a sash is limited up to 80 kg, if only two self-tapping screws the weight of the sash is limited up to 70 kg.





Fixing the connection

Installation tools

Straight cut

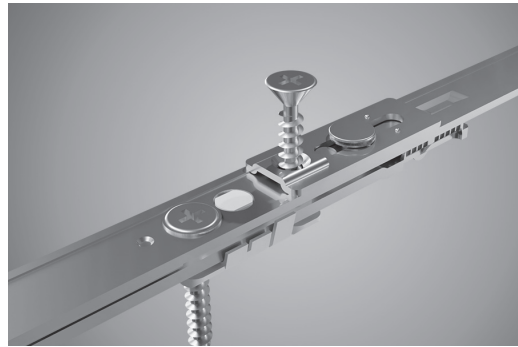
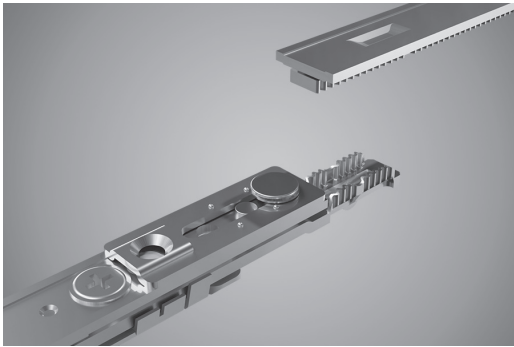

Eccentric cut

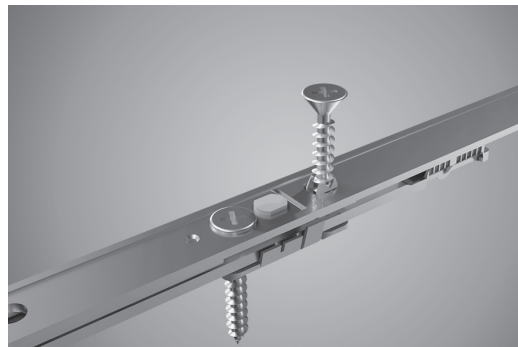
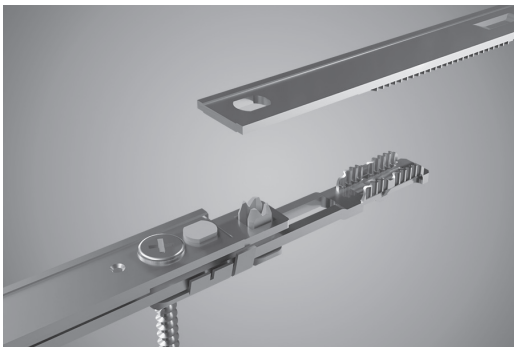

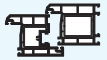

Punching machines

Installation tools

Punching machines

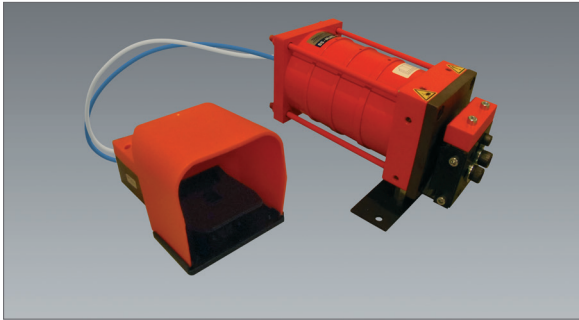

BS - Multi - Max® PS 100

- Integrated blow out function
- Straight cuts
- Punching Force at 6bar15 kN
- Working Pressure min 6-8 bar
- Working Pressure max.8 bar
- Foot switch
- Designed for small up to medium size production

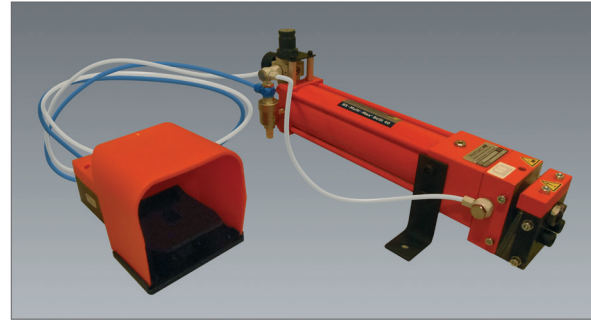

BS - Multi - Max® BeSt40

- Hydropneumatic drive
- Straight cut
- Working Pressure 6-8 bar
- Punching Force at 6,75 bar40 kN
- Max. punching force60 kN
- Max. pressure.....8 bar
- Foot control

The rulers

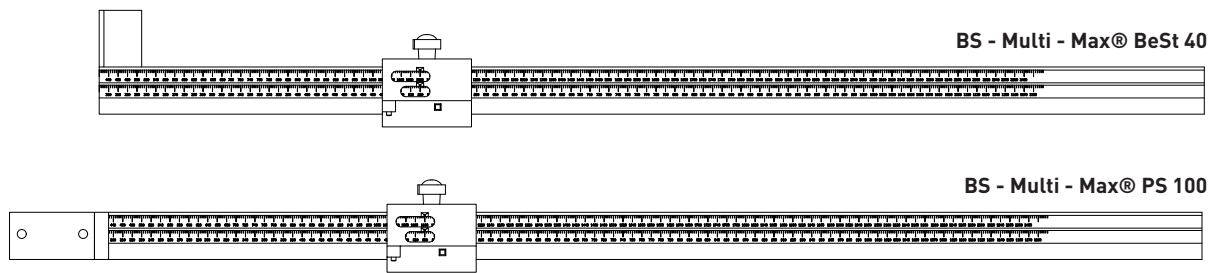

Description	Part No.
Punching machine BS-Multi-MAX BeSt40 with foot control	BeSt40-SVGL20
Punching machine BS-Multi-MAX PS100 with foot control	PS100-4-G-A-O-2-O
The ruler BS-Multi-MAX BeSt 40	A7041-01-N03
The ruler BS-Multi-MAX PS100	A7041-02-N03
The ruler for constant gears K3, BS-Multi-MAX BeSt 40	A7041-05-L03/R03
The ruler for constant gears K3, BS-Multi-MAX PS100	A7041-06-L03/R03



Punching machines

Installation tools

Punching machines



PS100-3-S5-GL20

- Integrated blow out function
- Eccentric cut
- Hydropneumatic drive 0,6 MPa (6 bar) 15 kN
- Working pressure, min.....6 bar
- Working pressure, max..... 1 MPa (10 bar)
- Foot switch
- Designed for small up to medium size production

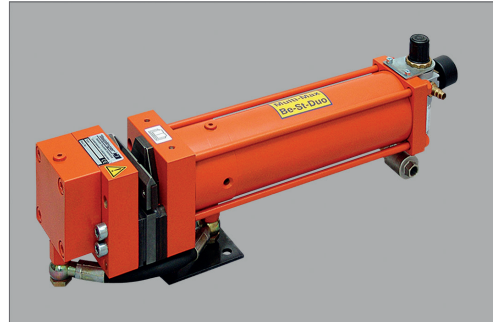

BSD-S5-SHGL20

- Hydropneumatic drive
- Eccentric cut
- Working pressure..... 6-10 bar
- Operating pressure6 bar
- Matrix28 kN
- Push rod18 kN
- Maximum pressure 10 bar
- Foot switch

The rulers

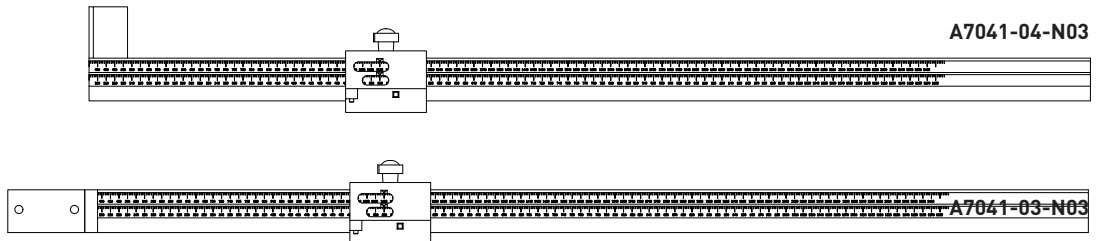

A7041-04-N03

A7041-03-N03

Description	Part No.
Punching machine BSD-"S5-SHGL20, left with foot control	BSD-S5-SHGL20
Punching machine BS-Multi-MAX PS100 with foot control	PS100-3-S5-GL20
The ruler BSD-S5-SHGL20	A7041-03-N03
The ruler PS100-3-S5-GL20	A7041-04-N03



An order of the hardware installation

Installation tools

An order of the hardware installation for a sash, straight cut

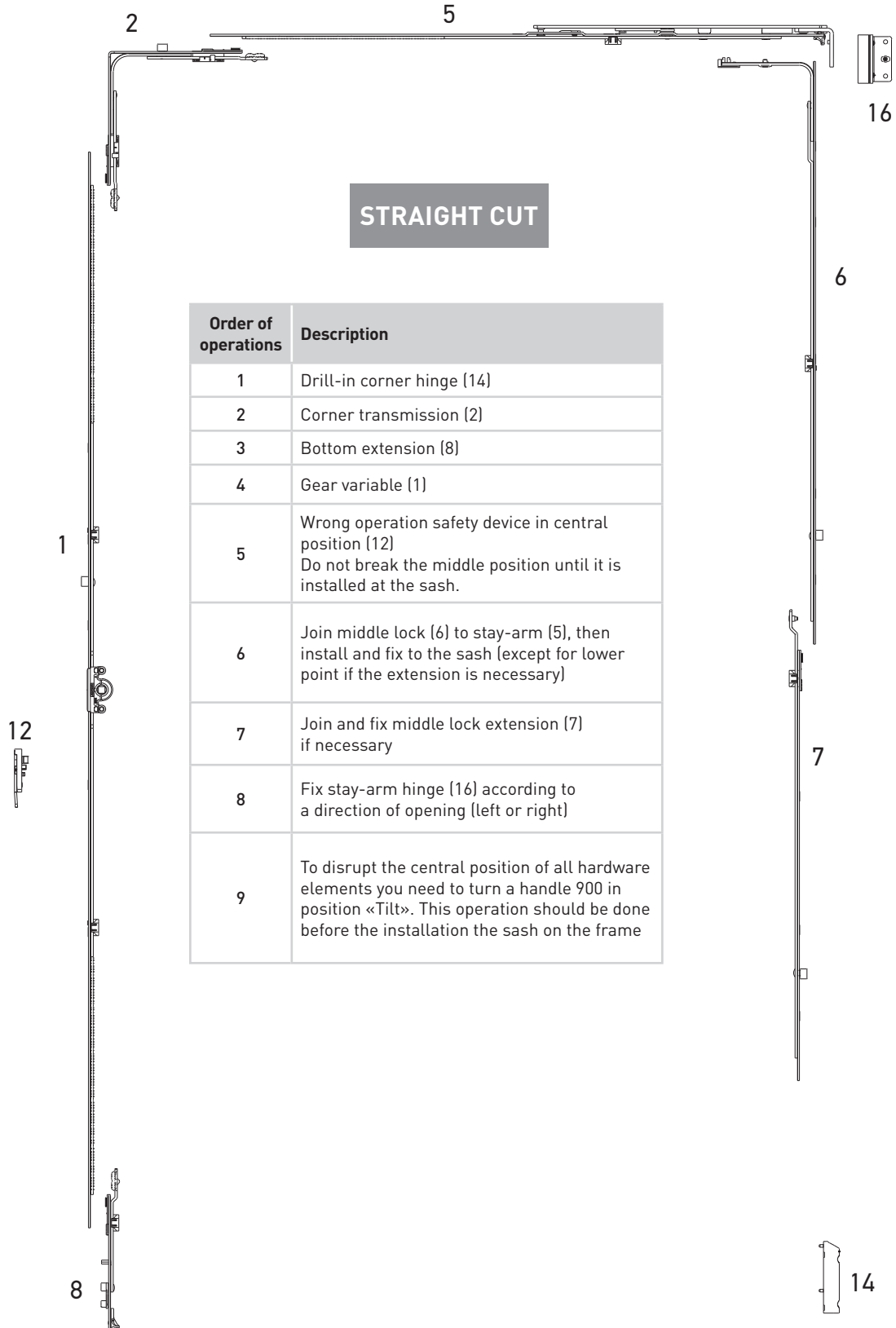



An order of the hardware installation

Installation tools

An order of the hardware installation for a sash, eccentric cut

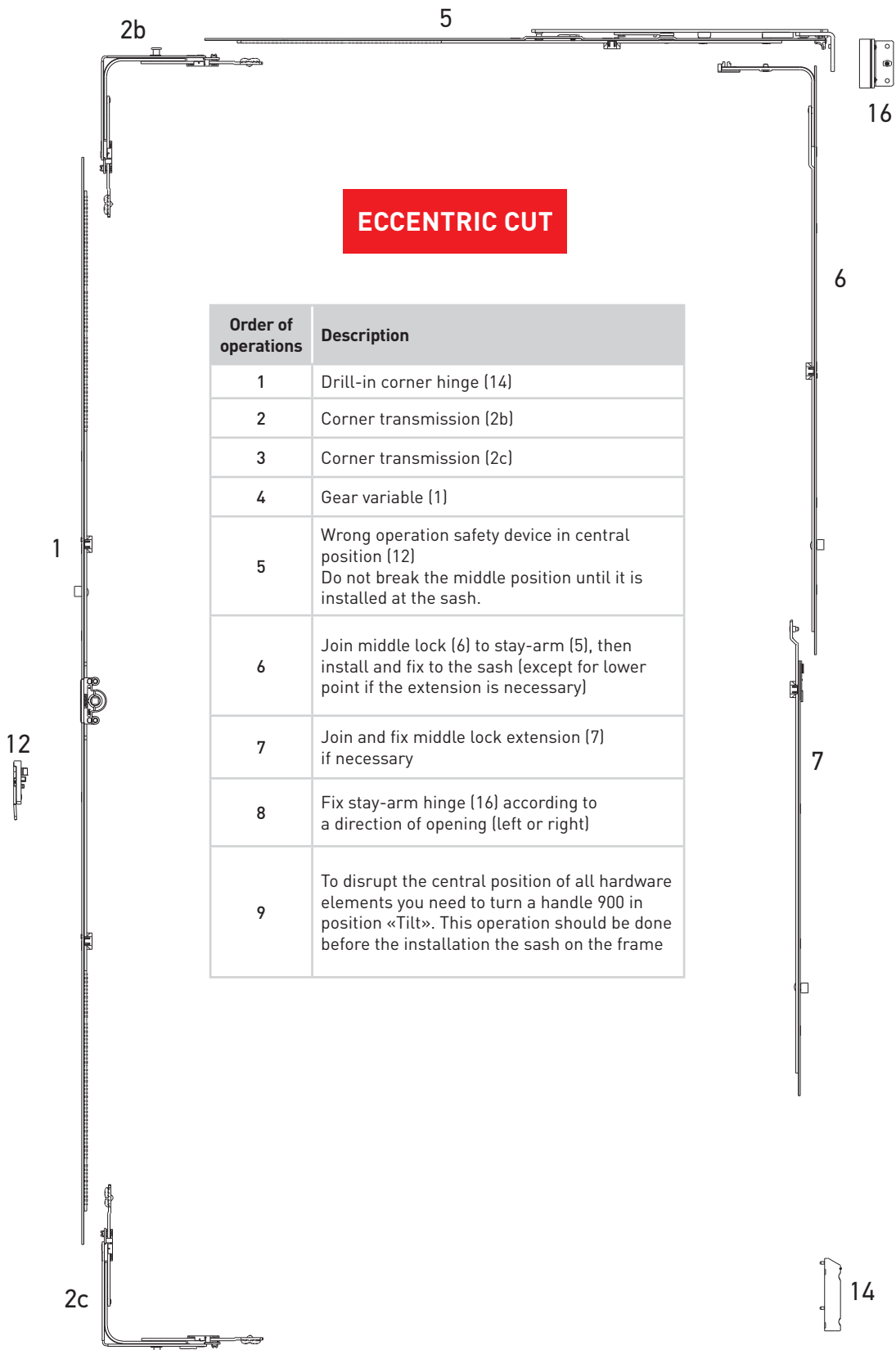

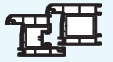

An order of the hardware installation

Installation tools

An order of the hardware installation for a frame

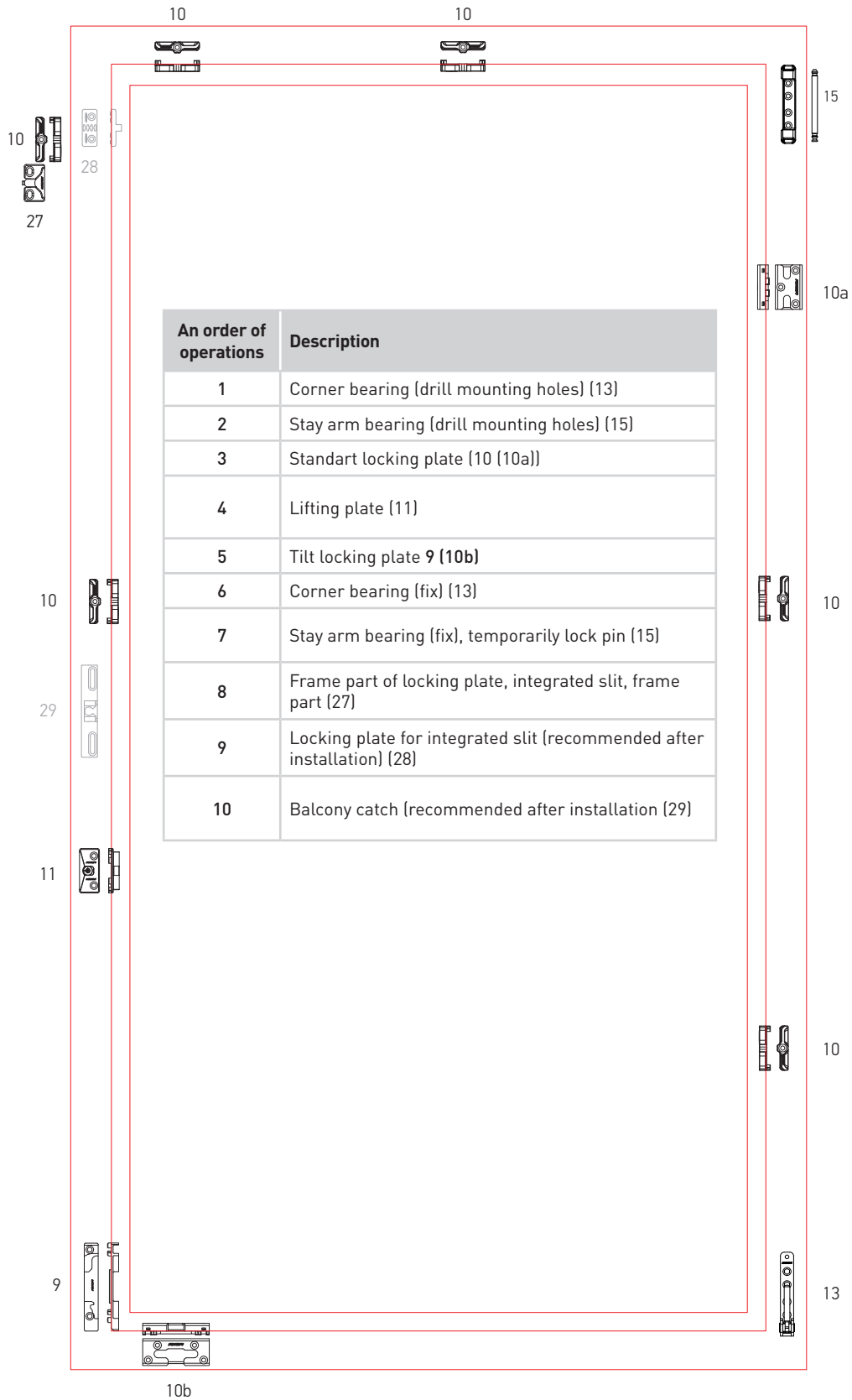

AXORTM

KOMFORT LINE K-3

Profile-dependent elements

AXOR



Profile list

Profile-dependent elements

Profile	B	Tilt locking plate	Locking plate	Lifting plate	Locking plate, integrated slit	Locking plate for adjustable integrated slit	Safety locking plate	Tilt safety locking plate	Tilt locking plate «First Tilt»	Locking plate adjustable for shoot bolt
ALUPLAST IDEAL 2000	13	K6004-13-L/R03	A7012-13-N03	A6003-13-N03	A6002-13-N03	A6004-00-N03	S6001-13-N03	S6002-13-N03	S6015-13-L/R03	K6002-13-N03
ALUPLAST IDEAL 4000	13	K6004-13-L/R03	A7012-13-N03	A6018-13-N03	A6002-13-N03	A6004-00-N03	S6023-13-N03	S6024-13-N03	S6034-13-L/R03	K6002-13-N03
ALUPLAST IDEAL 5000	13	K6004-13-L/R03	A7012-13-N03	A6018-13-N03	A6002-13-N03	A6004-00-N03	S6023-13-N03	S6024-13-N03	S6034-13-L/R03	K6002-13-N03
ALUPLAST IDEAL 8000	13	K6004-13-L/R03	A7012-13-N03	A6018-13-N03	A6002-13-N03	A6004-00-N03	S6023-13-N03	S6024-13-N03	S6034-13-L/R03	K6002-13-N03
BROKELMANN 58	13	K6001-13-L/R03	A7034-13-N00	A6003-13-N03	A6002-13-N03	A6004-00-N03	S6010-13-N03	S6011-13-N03	S6085-13-L/R03	K6002-13-N03
BROKELMANN 70	13	K6004-13-L/R03	A7012-13-N03	A6003-13-N03	A6002-13-N03	—	S6114-13-N03	S6115-13-N03	S6036-13-L/R03	K6002-13-N03
DECEUNINCK	13	K6008-13-L/R03	A7044-13-N03	A6010-13-N03	A6012-13-N03	A6045-13-N03	S6012-13-N03	S6013-13-N03	—	K6021-13-N03
DECEUNINCK EVEREST, ZENDOW, LEGEND	13	K6020-13-L/R03	A7153-13-N03	A6003-13-N03	A6002-13-N03	A6004-00-N03	S6112-13-N03	S6113-13-N03	S6066-13-L/R03	K6002-13-N03
GEALAN	13	K6009-13-L/R03	A7042-13-N03	A6003-13-N03	A6002-13-N03	A6004-00-N03	S6014-13-N03	S6022-13-L/R03	—	K6002-13-N03
GEALAN 9000N	13	—	A7066-13-N03	—	—	—	—	—	—	—
KBE 58/9	9	K6003-09-L/R03	A7013-09-N03	A6007-09-N03	A6005-09-N03	A6004-00-N03	S6003-09-N03	S6004-09-N03	S6047-09-L/R03	K6002-09-N03
KBE 58/9 Plus	9	K6003-09-L/R03	A7043-09-N03	A6007-09-N03	A6005-09-N03	A6004-00-N03	S6003-09-N03	S6004-09-N03	S6047-09-L/R03	K6002-09-N03
KBE 58/13	13	K6001-13-L/R03	A7011-13-N03	A6003-13-N03	A6002-13-N03	A6004-00-N03	S6010-13-N03	S6011-13-N03	S6068-13-L/R03	K6002-13-N03
KONING 70	13	K6004-13-L/R03	A7012-13-N03	A6003-13-N03	A6014-13-N03	—	S6114-13-N03	S6115-13-N03	S6036-13-L/R03	K6002-13-N03
MIROPLAST WDS 55	13	K6001-13-L/R03	A7011-13-N03	A6003-13-N03	A6002-13-N03	A6004-00-N03	S6001-13-N03	S6002-13-N03	S6015-13-L/R03	K6002-13-N03
MIROPLAST WDS 65	13	K6001-13-L/R03	A7011-13-N03	A6003-13-N03	A6002-13-N03	A6004-00-N03	S6001-13-N03	S6002-13-N03	S6015-13-L/R03	K6002-13-N03
MIROPLAST WDS 75	13	K6001-13-L/R03	A7011-13-N03	A6003-13-N03	A6002-13-N03	A6004-00-N03	S6001-13-N03	S6002-13-N03	S6015-13-L/R03	K6002-13-N03
MIROPLAST WDS 85	13	K6001-13-L/R03	A7011-13-N03	A6003-13-N03	A6002-13-N03	A6004-00-N03	S6001-13-N03	S6002-13-N03	S6015-13-L/R03	K6002-13-N03

B - sash groove position

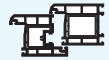

Profile list

Profile-dependent elements

Profile	B	Tilt locking plate	Locking plate	Lifting plate	Locking plate, integrated slit	Locking plate for adjustable integrated slit	Safety locking plate	Tilt safety locking plate	Tilt locking plate «First Tilt»	Locking plate adjustable for shoot bolt
REHAU BASIC DESIGN	13	K6004-13-L/R03	A7012-13-N03	A6003-13-N03	A6002-13-N03	A6004-00-N03	S6136-13-N03	S6137-13-N03	S6098-13-L/R03	K6002-13-N03
"REHAU BRILLANT DESIGN, CLIMA DESIGN, THERMO DESIGN"	13	K6004-13-L/R03	A7012-13-N03	A6003-13-N03	A6002-13-N03	A6004-00-N03	S6136-13-N03	S6137-13-N03	S6098-13-L/R03	K6002-13-N03
REHAU SYNEGO	13	K6004-13-L/R03	A7012-13-N03	A6003-13-N03	A6002-13-N03	A6004-00-N03	S6136-13-N03	S6137-13-N03	S6098-13-L/R03	K6002-13-N03
SALAMANDER DESIGN 2D	13	K6004-13-L/R03	A7012-13-N03	A6013-13-N03	A6014-13-N03	—	S6136-13-N03	S6137-13-N03	S6098-13-L/R03	K6002-13-N03
SALAMANDER DESIGN 3D	13	K6004-13-L/R03	A7012-13-N03	A6013-13-N03	A6014-13-N03	—	S6136-13-N03	S6137-13-N03	S6098-13-L/R03	K6002-13-N03
VEKA SOFTLINE 58	13	K6001-13-L/R03	A7011-13-N03	A6003-13-N03	A6002-13-N03	A6004-00-N03	S6001-13-N03	S6002-13-N03	S6015-13-L/R03	K6002-13-N03
VEKA SOFTLINE 70	13	K6001-13-L/R03	A7011-13-N03	A6003-13-N03	A6002-13-N03	A6004-00-N03	S6001-13-N03	S6002-13-N03	S6015-13-L/R03	K6002-13-N03
VEKA TOPLINE AD	13	K6001-13-L/R03	A7011-13-N03	A6003-13-N03	A6002-13-N03	A6004-00-N03	S6001-13-N03	S6002-13-N03	S6015-13-L/R03	K6002-13-N03
VIKALAND B70	13	K6004-13-L/R03	A7012-13-N03	A6003-13-N03	A6014-13-N03	—	S6114-13-N03	S6115-13-N03	S6036-13-L/R03	K6002-13-N03
WINTECH 532 (ISOTECH)	13	K6001-13-L/R03	A7011-13-N03	A6017-13-N03	A6015-13-N03	A6016-00-N03	S6007-13-N03	S6008-13-N03	S6081-13-L/R03	K6002-13-N03
WINTECH 632	13	K6001-13-L/R03	A7011-13-N03	A6003-13-N03	A6002-13-N03	A6004-00-N03	S6001-13-N03	S6002-13-N03	S6015-13-L/R03	K6002-13-N03
WINTECH 742	13	K6001-13-L/R03	A7011-13-N03	A6003-13-N03	A6002-13-N03	A6004-00-N03	S6001-13-N03	S6002-13-N03	S6015-13-L/R03	K6002-13-N03
WINTECH 752	13	K6001-13-L/R03	A7011-13-N03	A6003-13-N03	A6002-13-N03	A6004-00-N03	S6001-13-N03	S6002-13-N03	S6015-13-L/R03	K6002-13-N03
WINTECH 80	13	K6001-13-L/R03	A7011-13-N03	A6003-13-N03	A6002-13-N03	A6004-00-N03	S6001-13-N03	S6002-13-N03	S6015-13-L/R03	K6002-13-N03
Double sash	—	—	A7063-00-N03	A6001-00-N03 A6046-00-N03	—	—	—	—	—	—

B - sash groove position



Tilt anti-burglary locking plates FLAX pin

Profile-depending elements

Telescopic anti-burglary locking plate **FLAX**

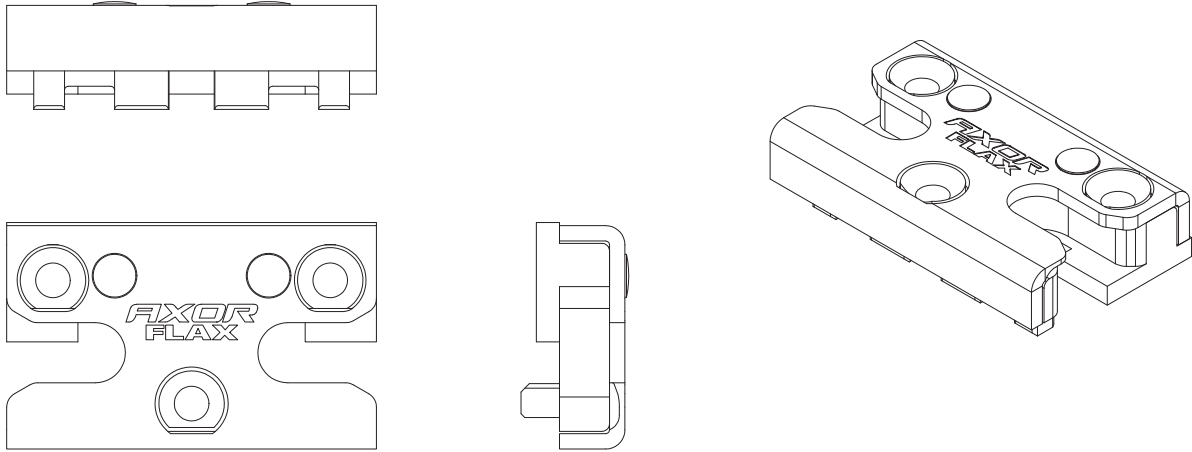

Tilt anti-burglary locking plate **FLAX**

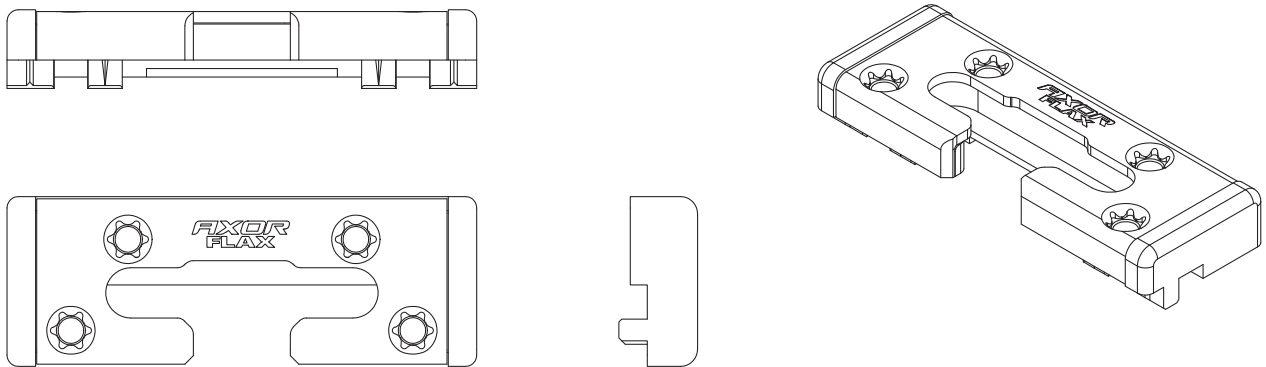

Description	Part No.
Telescopic anti-burglary locking plate, WDS, 13 mm, FLAX	S6171-13-N03
Telescopic anti-burglary locking plate, ALUPLAST, 13 mm, FLAX	S6175-13-N03
Tilt anti-burglary locking plate, WDS, 13 mm, FLAX	S6181-13-N03
Tilt anti-burglary locking plate, ALUPLAST, 13 mm, FLAX	S6185-13-N03



S6102-13-N03

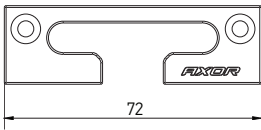
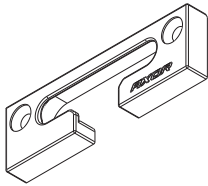

S6169-13-N03

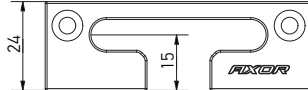
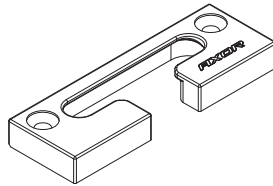

S6109-13-N03

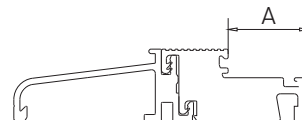
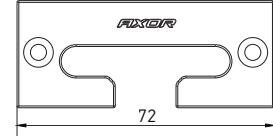
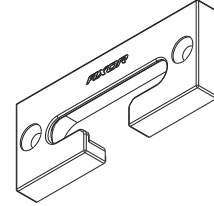

Description	A, mm	Part No.
Tilt safety locking plate, 13 mm, for aluminium doorstep, 22 mm	22	S6102-13-N03
Tilt safety locking plate, 13 mm, for aluminium doorstep, 24 mm	24	S6169-13-N03
Tilt safety locking plate, 13 mm, for aluminium doorstep, 30 mm	30	S6109-13-N03



Frame part of sash lifter

Profile-dependent elements

Frame part of sash lifter

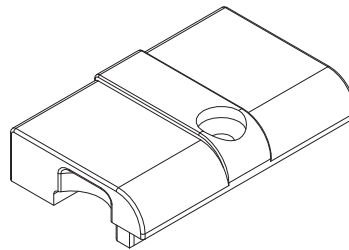
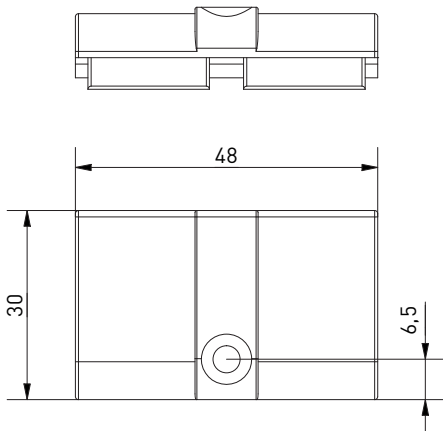

The frame part is compatible with WDS, VEKA, ALUPLAST 2000, VIKNALAND, SONAROL.

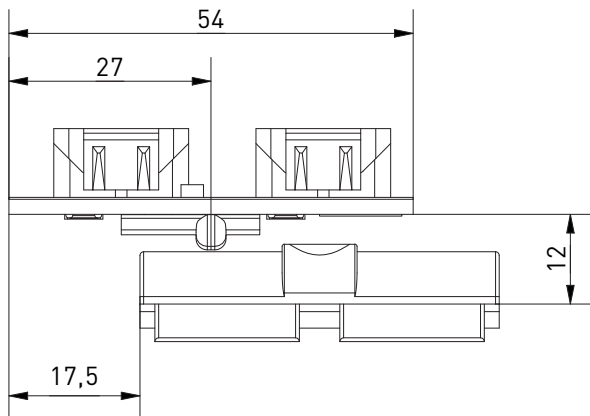

The single sash lifter A7236-00-N03 use together with the suitable frame part A7237-XX-N03.

The single sash lifter (A7236-01-N03) can be found on p. 148.

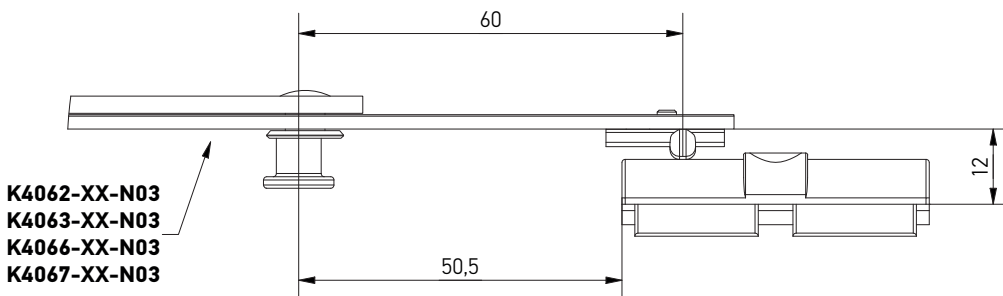

The extension locks K4062-XX-N03, K4063-XX-N03, K4066-XX-N03, K4067-XX-N03 use together with the suitable frame part A7237-XX-N03.

The extension locks can be found in the Section 3 "Corner transmissions / Middle locks".

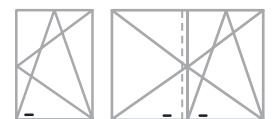

Description	Dimensions			Part No.
-------------	------------	--	--	----------

Frame part of sash lifter	48	1	100	A7237-01-N03
---------------------------	----	---	-----	--------------



AXOR INDUSTRY
32, Pratsi Avenue,
Dnipro, 49041, Ukraine.
www.axorindustry.com